



**Ovintiv™**

# British Columbia

Core

Dawson North / Dawson South

Field Supplements

Emergency Response Plan

**Ovintiv**  
500 Centre Street SE  
Calgary, AB T2P 2S5  
**Bus: 403-645-2000**

**H<sub>2</sub>Safety Services Inc.**  
210-7260 12 Street SE  
Calgary, AB T2H 2S5  
**Bus: 403-212-2332**



# REVISION HISTORY

This Emergency Response Plan is effective June 26<sup>th</sup>, 2025. The company's Emergency Response Program Coordinator is responsible for updating this plan annually or as required. Any errors or omissions in the plan should be brought to their attention.

<b>Annual ERP Update Due: June 26<sup>th</sup>, 2026</b>			
<b>Date of Issue</b>	<b>Reason for Revision</b>	<b>Section</b>	<b>Affected Pages</b>
June 26, 2025	Annual Update	Introduction	All Pages
		Section 1 – Initial Response	Section 3- External Notification Flowchart
		Section 5 – External Agencies	All Pages
		Section 6 – Forms	BCER – Form A BCER – Form D
November 4, 2024	Administrative Update Updating Internal Ovintiv Contacts	Introduction	Revision History Distribution List
		Section 1 – Initial Response	Step 2 - Internal Notification Flowchart
June 26, 2024	Annual Update	Introduction	All
		Section 1 - Initial Response	Step 2 - Internal Notification Flowchart Step 3 -External Notification Flowchart
		Section 5 – External Agencies	All Pages

# REVISION HISTORY, cont.

Date of Issue	Reason for Revision	Section	Affected Pages
June 26, 2023	Annual Update (Core) Updating references to BC OGC to BCER Updating references to EMBC to EMCR	Introduction	All
		Section 1 - Initial Response	Step 1- Level of Emergency Step 2 - Internal Notification Flowchart Step 3 -External Notification Flowchart
		Section 2 – Roles & Responsibilities	Key Response Personnel (Emergency Manager) Command Staff Roles
		Section 3 – Communication & Media	Page 1 - Guiding Principles and Approach
		Section 4 – Emergency Response Procedures	Public Protection Measures Section Page 2 Spill Response Section Spill Chart
		Section 5 – External Agencies	All Pages
		Section 6 – Forms	ICS 209
		Section 7 – Appendices	Pages 5-6: Training requirements / Plan maintenance Pages 25-36: Acronym Table / Glossary
June 26, 2022	Annual Update (Core)	Introduction	Cover Page Revision History Distribution List Table of Contents
		Section 1 - Initial Response	Step 2 - Internal Notification Flowchart Step 3 -External Notification Flowchart Step 5 - Public Protection Flowchart

# REVISION HISTORY, cont.

Date of Issue	Reason for Revision	Section	Affected Pages
June 26, 2022	Annual Update	Section 4 – Emergency Response Procedures	Table of Contents Public Protection Measures Section Spill Response Section
		Section 5 – External Agencies	All Pages
		Section 7 – Appendices	Pages 3-4 (HSE Policy)
June 26, 2021	Annual update (Core)	Introduction	Cover Page Revision History Distribution List
		Section 1 - Initial Response	Ovintiv Risk Matrix Internal Notification Flowchart External Notification Flowchart
		Section 5 – External Agencies	BC Notification Matrix BC Supporting Agencies Federal Agencies
Feb. 24, 2021	Updating media phone #	Section 3 - Communications & Media Forms – Prelim Media Stmt	Page 3 Form C1
June 26, 2020	Annual Update (Core) Converting from Encana to Ovintiv	All	All
		Introduction	Cover Page Revision History Distribution List
		Section 1 Initial Response	Internal Notification Flowchart
		Section 5 External Agencies	BC Notification Matrix BC Supporting Agencies Federal Agencies
June 26, 2019	Annual Update (Core)	Introduction	Cover Page Revision History Distribution List
		Section 5 External Agencies	BC Notification Matrix BC Lead Agencies BC Supporting Agencies Federal Agencies
		Section 7 Appendices	Pages 3-4

# REVISION HISTORY, cont.

Date of Issue	Reason for Revision	Section	Affected Pages
June 26, 2018	Annual Update (Core)	Introduction	Cover Page Revision History Distribution List
		Section 4 Public Protection Measures	Pages 1-2
		Section 5 External Agencies	BC Notification Matrix BC Lead Agencies BC Supporting Agencies Federal Agencies
		Section 7 Appendices	Pages 36, 38
June 2017	New ERP Manual	ALL	ALL

Distribution List

Manual #	Type	Res Info	Branch	Title / Agency	Name
<b>Corporate</b>					
100782	Binder	Full	Calgary	Senior Emergency Response Advisor	Tanner Strangway
100783	Binder	Full	Calgary	43rd Floor Bow Tower	EOC
100784	Binder	Full	Calgary	43rd Floor Bow Tower	Secondary EOC
100785	Binder	None	Calgary	Senior Drilling Technician	Sharron Winter
100786	Binder	None	Calgary	Drilling & Completions Spare	c/o Sharron Winter
100787	Binder	None	Dawson Creek	Rig Copy #1 (Core)	c/o Mike Cupples
100788	Binder	None	Dawson Creek	Rig Copy #2 (Core)	c/o Mike Cupples
100789	Binder	None	Dawson Creek	Rig Copy #3 (Core)	c/o Mike Cupples
100790	Binder	None	Dawson Creek	Rig Copy #4 (Core)	c/o Mike Cupples
100791	Binder	None	Dawson Creek	Rig Copy #5 (Core)	c/o Mike Cupples
100792	Binder	None	Dawson Creek	Completions Copy #1 (Core)	c/o Mike Cupples
100793	Binder	None	Dawson Creek	Completions Copy #2 (Core)	c/o Mike Cupples
100794	Binder	None	Dawson Creek	Completions Copy #3 (Core)	c/o Mike Cupples
100795	Binder	None	Dawson Creek	Completions Copy #4 (Core)	c/o Mike Cupples
100796	Binder	None	Dawson Creek	Completions Copy #5 (Core)	c/o Mike Cupples
100797	Binder	None	Grande Prairie	Lead, Operations Control Centre (OCC)	Aaron Penson
100798	Binder	Full	Grande Prairie	Operations Control Centre (OCC)	OCC Copy
100799	Binder	Full	Grande Prairie	Incident Command Post (ICP)	ICP Copy
100800	Binder	Full	Dawson Creek	Community Relations Advisor	Adam Rolick

**19 Hard Corporate Manuals**

<b>Field</b>					
100801	Binder	None	Dawson Creek	Field Coordinator, Dawson South, Tumbler Ridge (Core/DS)	Bryan Bonnett
100802	Binder	None	Dawson Creek	d-19-H / 93-P-09 Compressor (Core/DS)	c/o Bryan Bonnett
100803	Binder	None	Dawson Creek	01-34-78-17 W6M Compressor (Core/DS)	c/o Bryan Bonnett
100804	Binder	None	Dawson Creek	d-33-I / 93-P-08 Compressor (Core/DS)	c/o Bryan Bonnett
100805	Binder	None	Dawson Creek	a-29-H / 93-P-09 Compressor (Core/DS)	c/o Bryan Bonnett
100806	Binder	None	Dawson Creek	a-05-G / 93-P-09 Compressor (Core/DS)	c/o Bryan Bonnett
100807	Binder	None	Dawson Creek	09-15-77-15 W6M Compressor (Core/DS)	c/o Bryan Bonnett
100808	Binder	None	Dawson Creek	15-31-74-13 W6M Compressor (Core/DS)	c/o Bryan Bonnett
100809	Binder	None	Dawson Creek	South Central Liquids Hub c-41-G / 93-P-09 (Core/DS)	c/o Bryan Bonnett
100810	Binder	None	Dawson Creek	a-38-I / 93-P-01 (Core/DS)	c/o Bryan Bonnett
100811	Binder	None	Dawson Creek	a-62-I / 93-P-07 (Core/DS)	c/o Bryan Bonnett
100812	Binder	None	Dawson Creek	b-67-H / 93-P-10 (Core/DS)	c/o Bryan Bonnett
100813	Binder	None	Dawson Creek	c-27-B / 93-P-08 (Core/DS)	c/o Bryan Bonnett
100814	Binder	None	Dawson Creek	b-100-B / 93-P-08 (Core/DS)	c/o Bryan Bonnett
100815	Binder	None	Dawson Creek	c-29-A / 93-P-08 (Core/DS)	c/o Bryan Bonnett
100816	Binder	None	Dawson Creek	d-85-G / 93-P-07 (Core/DS)	c/o Bryan Bonnett
100817	Binder	None	Dawson Creek	Field Coordinator, Dawson North, Water Resource Hub 16-36-78-17 W6M (Core/D	Shawn Simmonds
100818	Binder	None	Dawson Creek	Water Resource Hub 16-36-78-17 W6M (Core/DN)	c/o Shawn Simmonds
100819	Binder	None	Dawson Creek	09-27-79-17 W6M Compressor (Core/DN)	c/o Shawn Simmonds
100820	Binder	None	Dawson Creek	Plant Coordinator, Sunrise Gas Plant 04-26-78-17 W6M (Core/DN)	Randy Munch
100821	Binder	None	Dawson Creek	Sunrise Gas Plant 04-26-78-17 W6M (Core/DN)	c/o Randy Munch
100822	Binder	None	Dawson Creek	15-27-79-17 W6M Gas Plant (Core/DN)	c/o Randy Munch
100823	Binder	None	Dawson Creek	North Central Liquids Hub 05-27-79-17 W6M (Core/DN)	c/o Randy Munch
100824	Binder	None	Dawson Creek	Tower Gas Plant 03-07-81-17 W6M (Core/DN)	c/o Randy Munch

**24 Hard Field Manuals**

Distribution List

Manual #	Type	Res Info	Branch	Title / Agency	Name
<b>External</b>					
100825	Binder	Full	Fort St. John	BC Energy Regulator (BCER)	Emergency Mgmt. & Safety
100826	Digital	None	Prince George	Emergency Management Climate Readiness (EMCR)	Heather MacRae
101311	Digital	None	Prince George	Northern Health Authority (NHA)	Chelan Zirul
100827	Digital	None	Dawson Creek	Peace River Regional District (PRRD)	Ryan Kirkham
100828	Digital	None	Fort St. John	Ministry of Transportation & Transit	Hali Davenport
100829	Digital	None	Chetwynd	RCMP (Chetwynd)	NCO In Charge
100830	Digital	None	Dawson Creek	RCMP (Dawson Creek)	NCO In Charge
100831	Digital	None	Tumbler Ridge	RCMP (Tumbler Ridge)	NCO In Charge
100832	Binder	None	Tomslake	Tomslake Fire Department	George Giersch
100833	Binder	None	Calgary	Veresen - Steeprock Gas Plant	Andre Carriere
100834	Binder	None	Calgary	Veresen - Hythe Gas Plant	Lane Flaten
100835	Digital	None	Calgary	Pembina Pipeline Corporation	Judy Scott
100836	Binder	Full	Calgary	H <sub>2</sub> Safety Services Inc.	H <sub>2</sub> Safety Library Copy

5 Hard External Manuals

8 Digital External Manuals

# Table of Contents

## Foreword

Cover Page	
Revision History .....	1
Distribution List .....	5
Table of Contents.....	7

## Section 1: Initial Response

A1 Initial Emergency Report Form	
Five Step Initial Response Guide	
Step 1 - Level of Emergency	
Step 2 - Internal Notification	
Step 3 - External Notification	
Step 4 - Incident Briefing	
Step 5 - Public Safety	

## Section 2: Roles and Responsibilities

### Field Response Team

#### Key Response Personnel

#### General Safety Equipment and Resource Lists

Operator, Truck & Other Safety Equipment

#### Field Response Team – Command Staff

Command Staff Roles Chart

#### Field Response Team – General Staff

Operations Section Roles Chart

Planning Section Roles Chart

Logistics Section Roles Chart

Finance / Admin. Section Roles Chart

#### Field Response Team – Public Safety Staff

Public Safety Staff Roles Chart

Air Monitors Module

Reception Centre Rep Module

Roadblocks Module

Rovers Module

Telephoners Module

#### Ongoing Response

Planning “P”

Five Step Ongoing Response Guide

Objectives Meeting

Tactics Meeting

Planning Meeting

Operations Briefing

**Section 3: Communications & Media**

Guiding Principles and Approach .....	1
Media Communications .....	2
Preliminary Media Statement .....	3

**Section 4: Emergency Response Procedures**

<b>Public Protection Measures .....</b>	<b>1</b>
Public Protection Measures Flowchart .....	1
Evacuation .....	2
Shelter-in-Place .....	3
Establishing and Isolating a Perimeter .....	11
Ignition .....	12
H <sub>2</sub> S / HVP Ignition Procedure .....	13
Road and Airspace Closures .....	15
Air Monitoring .....	15
<b>Spill Response, Containment and Recovery .....</b>	<b>1</b>
<b>Spill Response .....</b>	<b>1</b>
Spill Response Objectives and Strategies .....	1
Control Points .....	2
Health and Safety .....	4
Initial Site Assessment .....	4
Safety Briefing .....	4
Initial Site Safety and Hazard Control Plan .....	4
Western Canadian Spill Services (WCSS) .....	5
Provincial Petroleum Release Reporting Requirements Chart .....	7
<b>Containment and Recovery .....</b>	<b>9</b>
Understanding Environments – Ground and Water .....	9
Containment of Spilled Product .....	11
Containment to Recovery Process for Moving Water .....	15
Recovery of Spilled Product .....	16
Recovery Techniques .....	17
Spill Control Tactics (Sorbents, Berms, Trench and Bell Hole, Aquadam, Culvert Block, Boom Deployment, and Skimmers / Temporary Storage / Vacuum Units)	
<b>Post-Incident .....</b>	<b>1</b>
Call Down Notification .....	1
Public Care and Assistance .....	1
Clean-up and Repair .....	2
Third Party Investigations .....	2
Review and Debriefing .....	3
Critical Incident Stress Debriefing (CISD) .....	3
Post-Incident / Accident Investigation .....	4
<b>Medical Emergencies .....</b>	<b>1</b>
First Aid Information .....	2
Next-of-Kin Notification .....	5
Medical Evacuation (MEDEVAC) Procedure .....	7

**Section 4: Emergency Response Procedures, continued**

<b>Responder Safety .....</b>	<b>1</b>
Site Safety .....	1
On-Site Work Areas .....	2
Working Alone.....	4
Missing Persons.....	6
Rest Periods.....	6
<b>Fire / Explosion .....</b>	<b>1</b>
Classification of Fires.....	3
Response Actions Based on Type of Fire .....	4
Wildfire Response.....	9
<b>Transportation Incidents.....</b>	<b>1</b>
First On-Scene Transportation (Road, Rail, Marine) Incident Flowchart.....	1
Loss, Theft or Unlawful Interference Reporting Flowchart .....	2
Motor Vehicle Accidents .....	3
Emergency Response Assistance Canada (ERAC) plan .....	4
CANUTEC – Canadian Transport Emergency Centre .....	4
Dangerous Goods References .....	5
TDG Reportable Quantities.....	5
Rail Car Identification Chart.....	7
Road Trailer Identification Chart.....	9
Table of Markings, Labels and Placards.....	11
TDG 30 Day Follow-up Report Form .....	13
<b>Weather and Natural Disasters.....</b>	<b>1</b>
Earthquake.....	2
Floods .....	4
Thunderstorm and Lightning Safety.....	6
Tornados.....	7
Winter Storms: Blizzards, Freezing Rain, Heavy Snow, Blowing Snow .....	7
After a Disaster .....	9
<b>Security Incidents.....</b>	<b>1</b>
Responding to Threats.....	1
Bomb Threats.....	2
Suspicious Packages.....	5
Trespassing.....	7
Vandalism .....	8
Terrorism.....	8
Cyber-Attacks.....	9
<b>Animal Encounters .....</b>	<b>1</b>
First Responders to Animal Attacks.....	1
Bears .....	2
Cougars .....	4
Large Hooved Animals (Ungulates).....	6
Rattle Snakes.....	7

**Section 4: Emergency Response Procedures, continued**

Wolves .....	8
Bees and Wasps .....	9
EpiPens .....	10

**Section 5: External Agencies**

Provincial Notification Matrix
Provincial Lead Agency Roles
Government Consultation Summary
Specific Government Agency Roles
Health Services
Local Authority
Provincial Supporting Agency Roles
Federal Agency Roles

**Section 6: Forms**

Documentation During and After an Incident
Form Descriptions

**Incident Command System (ICS) Forms**

ICS 201 Incident Briefing
ICS 202 Incident Objectives
ICS 203 Organization Assignment List
ICS 204 Assignment List
ICS 207 Incident Organization Chart
ICS 208 Safety Message / Plan
ICS 209 Incident Status Summary
ICS 211 Check-In / Out List
ICS 214 Activity Log
ICS 215 Operational Planning Worksheet
ICS 215A IAP Safety Analysis
ICS 221 Demobilization Checkout
ICS 230 Meeting Schedule
ICS 231 Meeting Summary
ICS 233 Incident Open Action Tracker

**Emergency Forms**

A1 Initial Emergency Report Form
A2 Odour Complaint Script
A3 Regulatory First Call Communication
A4 Incident Action Plan (IAP) Checklist
A5 Air Monitoring Log
A6 Threatening Call / Bomb Threat
A7 STARS Landing Zone Card
A8 BCER Form A
A9 BCER Form D

**Section 6: Forms, continued**
**Resident Forms**

- B1 Reception Centre Registration Log
- B2 Resident Compensation Log
- B3 Resident Contact Log
- B4 Roadblock Log
- B5 Evacuation Notice
- B6 Early Notification / Voluntary Evacuation Phone Message
- B7 Shelter-In-Place Phone Message
- B8 Evacuation Phone Message

**Media Forms**

- C1 Preliminary Media Statement
- C2 Media Contact Log
- C3 Government Agency Contact Log
- C4 Media Centre Site

**Appendices**

<b>Appendix A: ERP Scope, Training and Plan Maintenance .....</b>	<b>1</b>
Scope .....	1
Plan Objectives .....	1
Purpose .....	1
HSE Policy .....	3
Training Requirements.....	5
Plan Maintenance .....	6
<b>Appendix B: Incident Command Post (ICP) .....</b>	<b>9</b>
Communication Methods Between Command Posts – British Columbia.....	9
ICP Activation and Setup .....	10
<b>Appendix C: Toxic Gases .....</b>	<b>12</b>
Hydrogen Sulphide (H <sub>2</sub> S).....	12
Sulphur Dioxide (SO <sub>2</sub> ).....	16
<b>Appendix D: Key Elements of the Incident Command System (ICS) .....</b>	<b>20</b>
Management by Objectives .....	20
Unity and Chain of Command.....	20
Organizational Flexibility .....	21
Span of Control .....	21
Common Terminology.....	21
Incident Action Plan (IAP).....	21
Integrated Communications .....	21
Establishment and Transfer of Command .....	22
Resources Management.....	22
Summary of Responsibilities.....	22
<b>Appendix E: Land Descriptions .....</b>	<b>23</b>
Dominion Land Survey (DLS) System.....	23
National Topographic System (NTS).....	24

**Appendices, continued**

<b>Appendix F: ERP Reference Material .....</b>	<b>25</b>
Acronyms.....	25
Glossary of Terms .....	26

**Area Specific Information****Expanded Site Section Summary****Facility Summary****Emergency Response Equipment**

- Safety Equipment
- Roadblock Kits
- Ignition Kits
- Field Specific Hazardous Products

**Telephone Directory**

- Corporate Emergency Operations Centre(s)
- Company Phone List
- Support Services & Contractors
- School Districts
- Schools

**Hazard Assessment****Area Overview Map****Dawson North Site Section**

- EPZ Calculations
- Dawson North Map

**Dawson South Site Section**

- EPZ Calculations
- Dawson South Map

**CER Site Section**

- EPZ Calculations
- CER Map

# Section 1: Initial Response

A1 Initial Emergency Report Form

Five Step Initial Response Guide

Step 1 – Level of Emergency

Step 2 – Internal Notification

Step 3 – External Notification

Step 4 – Incident Briefing

Step 5 – Public Safety

---

This page is intentionally left blank

---

# A1 Initial Emergency Report Form



## First On-Scene Actions

<b>Evacuate</b>	<input type="checkbox"/> Get to a safe area immediately. <input type="checkbox"/> Move upwind if release is downwind of you. <input type="checkbox"/> Move crosswind if a release is upwind from you. <input type="checkbox"/> Move to higher ground if possible.
<b>Alarm</b>	<input type="checkbox"/> Call for help ("Man Down"). <input type="checkbox"/> Sound bell, horn or whistle, or call by radio. <input type="checkbox"/> For medical emergencies, call 911.
<b>Assess</b>	<input type="checkbox"/> Take head count, locate any casualties. Consider all of the hazards. <input type="checkbox"/> Fill out information below to complete assessment.
<b>Protect</b>	<input type="checkbox"/> Put on breathing apparatus before attempting rescue.
<b>Rescue</b>	<input type="checkbox"/> Remove victim to a safe area.
<b>First Aid</b>	<input type="checkbox"/> Follow the standard first aid protocols at worksite. (CPR, etc.)
<b>Medical Aid</b>	<input type="checkbox"/> Arrange transport of casualties to medical aid. <input type="checkbox"/> Provide information to Emergency Medical Services (EMS).

Incident Details <i>To be completed by the person involved or notified</i>	
Report taken by	Date / Time
Name of person calling	Caller Telephone
Incident Location (LSD / NTS)	
Event Summary	
<b>Agencies Notified</b>	<input type="checkbox"/> Yes Who? <input type="checkbox"/> No
<b>Event Status</b>	<input type="checkbox"/> Incident contained or controlled <input type="checkbox"/> Imminent control possible <input type="checkbox"/> Intermittent control possible <input type="checkbox"/> Incident is uncontrolled
<b>Site Type</b>	<input type="checkbox"/> Well <input type="checkbox"/> Pipeline <input type="checkbox"/> Tank Farm/Storage <input type="checkbox"/> Battery/Plant/Facility <input type="checkbox"/> Other _____
<b>Incident Type</b>	<input type="checkbox"/> Sour Gas Release <input type="checkbox"/> Sweet Gas Release <input type="checkbox"/> Pipeline Break <input type="checkbox"/> Security (theft, threat, terrorism) <input type="checkbox"/> Loss of Containment <input type="checkbox"/> Fire/Explosion <input type="checkbox"/> Worker Injury/Fatality <input type="checkbox"/> Vehicle/Transportation <input type="checkbox"/> Liquid Spill <input type="checkbox"/> Other _____

# A1 Initial Emergency Report Form



Core Emergency Response Plan

Impacts			
<b>Public Health and Safety</b>	<input type="checkbox"/> Could be jeopardized		<input type="checkbox"/> Is jeopardized
<b>Public Protection Measures Taken</b>	<input type="checkbox"/> Notification <input type="checkbox"/> Evacuation <input type="checkbox"/> Shelter-in-place <input type="checkbox"/> Roadblocks		
<b>Worker Injuries</b>	<input type="checkbox"/> First Aid <input type="checkbox"/> Hospitalized <input type="checkbox"/> Fatality <input type="checkbox"/> Other _____		
Distance to nearest surface development	_____ km	Distance to nearest urban centre	_____ km
Details			
<b>Release Impact</b>	<input type="checkbox"/> On-Lease <input type="checkbox"/> Off-Lease                        Product _____		Amount _____
<b>Gas Readings</b>	H <sub>2</sub> S _____                        SO <sub>2</sub> _____                        LEL _____                        Other _____		
Distance to nearest watercourse	_____ km	Weather Conditions	
Details			
<b>Media Involvement?</b>	<input type="checkbox"/> Yes <input type="checkbox"/> No	<b>Regulator Involvement?</b>	<input type="checkbox"/> Yes <input type="checkbox"/> No
		<b>Public Affairs/Community Relations Issues?</b>	<input type="checkbox"/> Yes <input type="checkbox"/> No
Details			
Notes / Instructions Provided:			

**Distribute this completed report to all Key Response Personnel**

*Note: Ensure the First On-Scene Actions have been completed before proceeding to the Five Step Initial Response Guide.*

## First On-Scene Actions

Evacuate  
Alarm  
Assess  
Protect  
Rescue  
First Aid  
Medical Aid

Refer to A1 Initial Emergency Report Form

### Step 1 - Level of Emergency

Determine Level of Emergency:

- Alert / Minor
- Level 1 Emergency
- Level 2 Emergency
- Level 3 Emergency

Use the following resources:

- Section 1: Initial Response (Level of Emergency)
- The Emergency Assessment SmartPhone App. (Search H<sub>2</sub>Safety or Emergency Assessment in the App Store).



Note: The BCER and the AER state that the licensee must use either the Incident Classification Matrix (BC) or the Assessment Matrix for Classifying Incidents (AB) to determine the Level of Emergency. If the incident overlaps more than one level, always choose the highest level.

### Step 2 - Internal Notification

- Follow the Internal Emergency Notification Flowchart to determine who needs to be notified.
- Relay the information in the completed A1 Initial Emergency Report Form.
- Mobilize internal resources to the site, to the Incident Command Post (ICP), or place them on standby as required.

Use the following resources:

- Section 1: Initial Response (Internal Emergency Notification Flowchart)
- Section 3: Roles & Responsibilities (Response Team Phone List)
- Section 6: Forms (A1)
- Initiate an H<sub>2</sub>CommandCentre session.



### Step 3 - External Notification

- Follow the External Emergency Notification Flowchart to determine which external agencies need to be notified.

- 911 (police, fire, ambulance)
- Health Authority / Health Services
- Regulatory agency to confirm the Level of Emergency
- Air Monitoring (at all levels of emergency)
- Local Authority (Cities, Towns, Villages, Counties, M.D.s, R.D.s, R.M.s, Special Areas, Reserves, etc.)

Use the following resources:

- Section 1: Initial Response (External Emergency Notification Flowchart)
- Section 5: External Agencies (Provincial Notification Matrix)
- Area Specific Information (White tabs)

### Step 4 - Incident Briefing

Complete an ICS 201 Incident Briefing Form:

- Define incident details and an operational period (page 1).
  - Establish the On-Site Command Post (OSCP) and ICP.
- Document current incident objectives, strategies and tactics (page 2).
- Prioritize objectives (page 2).
- Define initial Incident Command Structure (page 3).
- Identify required resources and when they'll be available (page 4).

Use the following resources:

- Section 1: Initial Response (ICS 201)
- Section 6: Forms (ICS 201)

### Step 5 - Initiate Public Safety

#### Public Protection Measures

- Determine the hazard area; start with Emergency Planning Zone (EPZ) as default.
- Identify the affected surface developments and area users. (Houses, businesses, guides/outfitters, trappers, schools, other oil and gas operators, etc.)
- Determine the appropriate public protection measure for the affected surface developments and area users. (Evacuation, shelter-in-place and/or ignition)
- Coordinate evacuation outside of the EPZ with the local authority, if required.
- Utilize broadcast media to notify public outside of the EPZ in immediate evacuation situations.

Use the following resources:

- Section 1: Initial Response (Public Protection Measures Flowchart)
- Section 2: Emergency Response Procedures (Public Protection Measures)
- Area Specific Information (Map / EPZ calculation tables)

#### Rovers

- Dispatch Rovers to patrol the EPZ.
- Follow safety procedures and have appropriate PPE.
- Search the EPZ for transients.
- Assist residences that require evacuation assistance.
- Investigate surface developments that are identified as vacant or those who were unable to contact.
- Post notices on all outside doors of empty surface developments, vehicles, etc.
- Record all contacts, communications and monitoring readings using the following forms: ICS 214, A5, B3 & B5.
- Monitor and record air quality readings using the following forms: ICS 214 & A5. (Smoke, plumes, wind, etc.)
- Provide status updates to the Public Safety Group Supervisor at established intervals; utilize H<sub>2</sub>CommandCentre if available.

Use the following resources:

- Section 3: Roles & Responsibilities (Rovers)
- Section 6: Forms
- Area Specific Information (Map)

#### Telephoners

- Establish a Telephoner Team to notify residents to evacuate or shelter-in-place as required.
- Notify special needs residents at a Level 1 Emergency and provide the option to evacuate voluntarily.
- Follow-up phone calls to address resident inquiries.
- Record all phone calls and communications using the following forms: ICS 214, B3, B6, B7, & B8.
- Provide status updates to the Public Safety Group Supervisor at established intervals; utilize H<sub>2</sub>CommandCentre if available.

Use the following resources:

- Section 3: Roles & Responsibilities (Telephoners)
- Section 6: Forms

#### Roadblocks

- Follow safety procedures to safely establish roadblocks wherever a road intersects with the EPZ and advise vehicles to reroute.
- Record all vehicle encounters and air monitoring readings. Complete the following forms: ICS 214, A5, B3 & B4.
- Gain permission from the Public Safety Group Supervisor for response vehicles to enter the hazard area.
- Provide status updates to the Public Safety Group Supervisor at established intervals; utilize H<sub>2</sub>CommandCentre if available.

Use the following resources:

- Section 3: Roles & Responsibilities (Roadblocks)
- Section 6: Forms
- Area Specific Information (Map)

#### Air Monitors

- Dispatch Air Monitoring personnel to the nearest residence / public facility downwind of the incident.
- Follow safety procedures and have appropriate PPE.
- Monitor and record air quality readings using the following forms: ICS 214 & A5. (Smoke, plumes, wind, etc.)
- Provide status updates to the Public Safety Group Supervisor at established intervals; utilize H<sub>2</sub>CommandCentre if available.

Use the following resources:

- Section 3: Roles & Responsibilities (Air Monitors)
- Section 6: Forms

#### Reception Centre Rep

- If residents are evacuated, dispatch a Reception Centre Representative to the reception centre location.
- Meet and register evacuated residents.
- Record contact information for those who choose to stay elsewhere. Complete the following forms: ICS 214, B1, B2 & C2.
- Regularly provide status updates to the Public Safety Group Supervisor (those who have arrived and those who have not yet arrived); utilize H<sub>2</sub>CommandCentre if available.

Use the following resources:

- Section 3: Roles & Responsibilities (Reception Centre Rep)
- Section 6: Forms

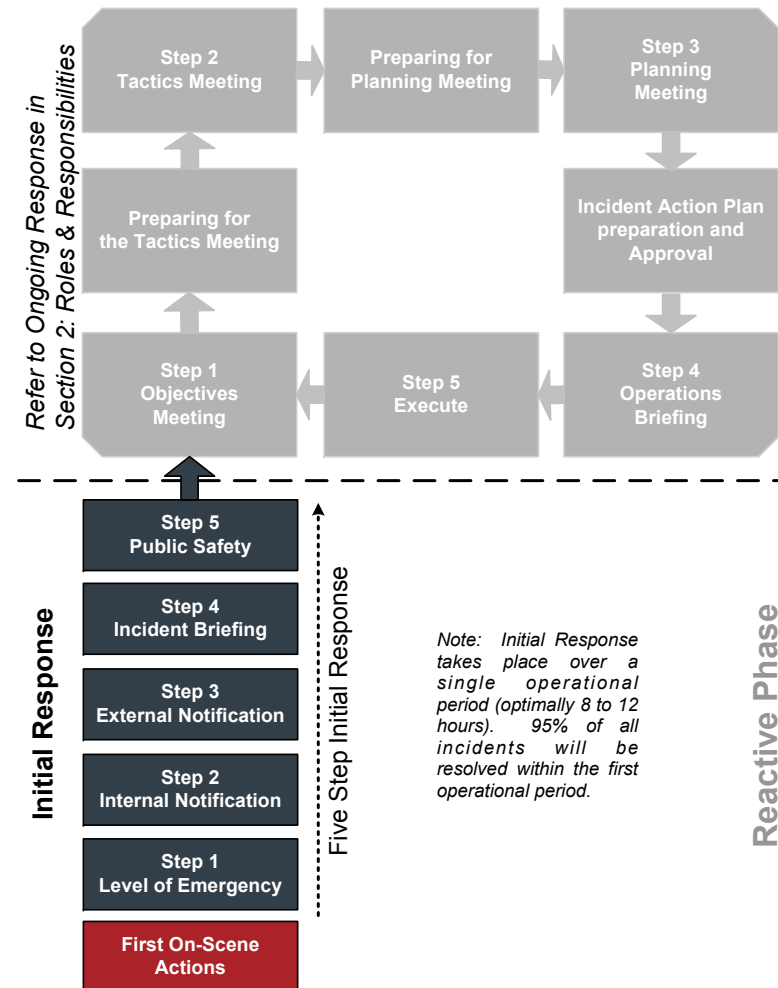

# Five Step Initial Response Guide



This page is intentionally left blank

---



## Incident Classification Matrix

**Instructions:** Start at the top and continue down until you check off any one box in both consequence and probability to determine the incident classification. *This matrix is required as an attachment upon submission of an incident through the [Online Minor Incident Reporting System](#).*

**Table 1. Consequence Ranking**

Rank	Consequence (any one of the following)
4	<input type="checkbox"/> Major on site equipment or infrastructure loss <input type="checkbox"/> Major act of violence, sabotage, or terrorism which impacts permit holder assets <input type="checkbox"/> Reportable liquid spill beyond site, uncontained and affecting environment <input type="checkbox"/> Gas release beyond site affecting public safety
3	<input type="checkbox"/> Threats of violence, sabotage, or terrorism <input type="checkbox"/> Reportable liquid spill or gas release beyond site, potentially affecting public safety, environment, or property <input type="checkbox"/> HAZMAT worker exposure exceeding allowable <input type="checkbox"/> Major on site equipment failure
2	<input type="checkbox"/> Major on site equipment damage <input type="checkbox"/> A security breach that has potential to impact people, property or the environment <input type="checkbox"/> Reportable liquid spill or gas release potentially or beyond site, not affecting public safety, environment, or property
1	<input type="checkbox"/> Moderate on site equipment damage <input type="checkbox"/> A security breach that impacts oil and gas assets <input type="checkbox"/> Reportable liquid spill or gas release on location <input type="checkbox"/> **Occurrence of magnitude 4.0 or greater induced earthquake within 3 km of oil and gas operations or any earthquake which is felt on surface within a 3 km radius of oil and gas operations
0	<input type="checkbox"/> No consequential impacts

\*\* For this consequence criteria, a probability score of 2 or higher must be used.

**Table 2. Probability Ranking**

Rank	Probability (any one of the following)
4	<input type="checkbox"/> Uncontrolled, with control unlikely in near term
3	<input type="checkbox"/> Escalation possible; under or imminent control
2	<input type="checkbox"/> Escalation unlikely; controlled or likely imminent control
1	<input type="checkbox"/> Escalation highly unlikely; controlled or imminent control
0	<input type="checkbox"/> Will not escalate; no hazard; no monitoring required

**Table 3. Incident Risk Score and Classification**

Consequence \_\_\_\_\_ + Probability \_\_\_\_\_ = Risk Score \_\_\_\_\_ (this must be completed)

Risk Score	Assessment Result
Minor (1-2)	<b>Notification Only;</b> permit holder must notify the BCER online within 24 hours using the <a href="https://bc-er.ca/node/11188">Form A: Minor Incident Notification Form (https://bc-er.ca/node/11188)</a> . In addition to Form A, spills must also be reported to EMCR.
Moderate (3-4)	<b>Level-1 Emergency;</b> immediate notification (call EMCR)
Major (5-6)	<b>Level-2 Emergency;</b> immediate notification (call EMCR)
Serious (7-8)	<b>Level-3 Emergency;</b> immediate notification (call EMCR)

**Emergency** The H<sub>2</sub>Safety Services Inc. Emergency Assessment Smart Phone app is the preferred method for determining the level of emergency. Search H<sub>2</sub>Safety or Emergency Assessment in the Apple or Android app store.



Probability
-------------

# Step 1 – Level of Emergency



BCER Incident Classification Matrix		4	3	2	1	0	
		Uncontrolled, with control unlikely in near term	Escalation possible; under or imminent control	Escalation unlikely; controlled or likely imminent control	Escalation highly unlikely; controlled or imminent control	Will not escalate; no hazard; no monitoring required	
Consequence	4	<input type="checkbox"/> Major on site equipment or infrastructure loss <input type="checkbox"/> Major act of violence, sabotage, or terrorism which impacts permit holder assets <input type="checkbox"/> Reportable liquid spill beyond site, uncontained and affecting environment <input type="checkbox"/> Gas release beyond site affecting public safety	Level 3	Level 3	Level 2	Level 2	Level 1
	3	<input type="checkbox"/> Threats of violence, sabotage, or terrorism <input type="checkbox"/> Reportable liquid spill or gas release beyond site, potentially affecting public safety, environment, or property <input type="checkbox"/> HAZMAT worker exposure exceeding allowable <input type="checkbox"/> Major on site equipment failure	Level 3	Level 2	Level 2	Level 1	Level 1
	2	<input type="checkbox"/> Major on site equipment damage <input type="checkbox"/> A security breach that has potential to impact people, property or the environment <input type="checkbox"/> Reportable liquid spill or gas release potentially or beyond site, not affecting public safety, environment, or property	Level 2	Level 2	Level 1	Level 1	Minor Notification Form
	1	<input type="checkbox"/> Moderate on site equipment damage <input type="checkbox"/> A security breach that impacts oil and gas assets <input type="checkbox"/> Reportable liquid spill or gas release on location <input type="checkbox"/> ** Occurrence of magnitude 4.0 or greater induced earthquake within 3 km of oil and gas operations or any earthquake which is felt on surface within a 3 km radius of oil and gas operations	Level 2	Level 1	Level 1	Minor Notification Form	Minor Notification Form
	0	<input type="checkbox"/> No consequential impacts	Level 1	Level 1	Minor Notification Form	Minor Notification Form	No Notification Required

**Minor Incidents**

- The permit holder must report the minor incident to the BCER within 24 hours by electronic submission through the Online Minor Incident Reporting System, opened through KERMIT.
- If the minor incident involves a leak or a spill, EMCR must also be called at 1-800-663-3456 so that a Dangerous Goods Incident Report (DGIR) number may be issued.

**Level 1, 2, or 3 Emergency**

- If the incident receives a score of Level 1, 2, or 3, it must be **reported immediately (within 1 hour)** to the BCERs incident reporting line (EMCR 1-800-663-3456).

**Escalating, Downgrading or Standing-Down of Emergency**

- The BCER must be notified as soon as possible of any change to the emergency status.
- The permit holder must consult with the BCER for escalating, downgrading or the standing-down of an incident.

**Permit Holders Post-Incident Report**

The [Form D: Permit Holder Post Incident Report Form \(https://bc-er.ca/node/5771\)](https://bc-er.ca/node/5771) must be submitted by the permit holder to the BCER within 60 days for:

- Any Level 1, 2 or 3 emergency incident: complete Part A-P; or
- Any pipeline incident (including minor notification): complete Part A-U; or
- Upon request by the BCER

This report and accompanying documentation can be found on the BCERs website under Emergency Response and Planning and must be emailed electronically to [EMP@bc-er.ca](mailto:EMP@bc-er.ca).

\*\* For this consequence criteria, a probability score of 2 or higher must be used.

### Spill Reporting Criteria

Where the permit holder holds or maintains rights, the permit holder must report to the BC Energy Regulator, all spills of materials as identified below:

- A spill or release of any amount of materials which impacts water ways
- Hydrocarbons; 100 litres where the hydrocarbon contains no toxic materials and does not impact water ways
- Produced/salt water; 200 litres where the fluid contains no toxic materials
- Fresh water; 10,000 litres
- Drilling or invert mud; 100 litres
- Sour Natural gas; 10 kg or 15 m<sup>3</sup> by volume where operating pressure is >100 PSI
- Condensate; 100 litres
- Any fluid including hydrocarbons, drilling fluids, invert mud, effluent, emulsions, etc. which contain toxic substances; 25 litres

Please refer to the BC Environmental Management Act; [Spill Reporting Regulation](#), Schedule “Reporting Levels for Certain Substances” for determining reportable spillage amounts of other substances:

### Other Reportable Incidents

The BCERs Incident Risk Classification Matrix is designed to assist permit holders in determining which incidents must be reported. However, some incidents, which do occur, may not meet the criteria outlined in the Incident Classification Matrix but still require notification to the BCER as a minor notification. These include the following:

- Spills or release of hazardous substances which are not provincially regulated, such as radioactive substances;
- Major damage to oil and gas roads or road structures;
- Drilling kicks when any one of the following occur:
  - pit gain of 3 m<sup>3</sup> or greater
  - casing pressure 85% of MA
  - 50% out of hole when kicked
  - well taking fluid (LC)
  - associated spill
  - general situation deterioration, i.e. leaks, equipment failure, unable to circulate, etc
- All pipeline incidents, such as spills during construction phase, exposed pipe caused by flooding, pipeline over pressure, failure (without release) of any pressure control or ESD device during operations
- Security related issues which are relatively minor; such information may be required for tracking and monitoring purposes only

### Sour Gas

When a sour gas product is released, any measurement of 10 ppm or greater measured at 1 metre from the source of the leak requires reporting as an incident.

### Releases Near Airports

If the emergency involves the release of flammable vapour at the site of an oil and gas activity that is located within 2 kilometres of an airport, immediately notify the operator of the airport.

## Oil and Gas Road Closures

In emergency situations, permit holders must phone the BCERs 24 hour Incident Reporting line to notify the BCER of needed emergency oil and gas road closures.

## Special Sour Wells

During an emergency involving a special sour well, a permit holder must do all of the following:

1. Ensure that a person certified in accordance with subsection (4) is available and equipped to ignite the well within the time limits set out in the plan in respect of which the emergency planning zone was determined;
2. Ensure that a dual ignition system is on site during:
  - a. Drilling or completion operations, or
  - b. Workover operations being carried out at any time when the wellhead is not in place;
3. Ensure that a person authorized to ignite flammable liquids or ignitable vapours released from the well is on site.

For the purposes of subsection (2), a sour well is special if either of the following applies:

1. The hydrogen sulphide release rate from the well is equal to or greater than 2.0 m<sup>3</sup>/s;
2. The hydrogen sulphide release rate from the well is less than 2.0 m<sup>3</sup>/s but greater than 0.5 m<sup>3</sup>/s and the well is located within a distance that is twice the hazard planning distance from the corporate boundaries of an urban centre.

For the purposes of subsection (2) (a), the person must have vapour plume ignition certificate issued by a training association.

**Note:** Refer to the *Petroleum Industry Spill / Release Reporting Requirements in Section 4: Emergency Response Procedures* for further spill reporting criteria and the *Government Notification Matrix in Section 5: External Agencies* for other reportable incidents.

# Ovintiv Operational Risk Matrix



## STEP 1: Evaluate Consequence

Level	Health and Safety	Environment	Asset (\$)	Regulatory
4 Critical	<ul style="list-style-type: none"> <li>Fatality.</li> <li>Long-term health impact.</li> <li>Life-threatening or life-altering.</li> <li>Evacuation of a community.</li> </ul>	<ul style="list-style-type: none"> <li>Persistent, severe environmental damage that will lead to a loss of commercial, recreational use.</li> <li>Loss of natural resources over a wide area.</li> </ul>	<ul style="list-style-type: none"> <li>Production, equipment, property, schedule interruption.</li> <li>Damage greater than US \$10 MM.</li> </ul>	<ul style="list-style-type: none"> <li>Action resulting in regulatory and/or legal prosecution or suspension of operations.</li> <li>Prolonged national/international media/public attention.</li> </ul>
3 Serious	<ul style="list-style-type: none"> <li>Serious injury/illness.</li> <li>Lost time injury.</li> <li>Short-term health impact.</li> <li>Evacuation of a facility and immediate area.</li> </ul>	<ul style="list-style-type: none"> <li>Severe environmental damage that will require extensive measures to restore beneficial use of the environment.</li> <li>Serious impact to public.</li> </ul>	<ul style="list-style-type: none"> <li>Production, equipment, property, schedule interruption.</li> <li>Damage greater than US \$1 MM.</li> </ul>	<ul style="list-style-type: none"> <li>Regulatory and/or legal action resulting in fines or punitive action.</li> <li>Prolonged national/regional media/public attention.</li> </ul>
2 Moderate	<ul style="list-style-type: none"> <li>Restricted work/medical aid injury/illness.</li> <li>Evacuation of job site.</li> </ul>	<ul style="list-style-type: none"> <li>Limited, persistent environmental damage that will require clean-up.</li> </ul>	<ul style="list-style-type: none"> <li>Production equipment, property, schedule interruption.</li> <li>Damage greater than US \$100,000.</li> </ul>	<ul style="list-style-type: none"> <li>Regulatory and/or legal action resulting in administrative response.</li> <li>Brief local/regional media/public attention.</li> </ul>
1 Minor	<ul style="list-style-type: none"> <li>First Aid injury or illness.</li> </ul>	<ul style="list-style-type: none"> <li>Localized, short term environmental damage with no lasting impact.</li> </ul>	<ul style="list-style-type: none"> <li>Production, equipment, property, schedule interruption.</li> <li>Damage less than US \$100, 000.</li> </ul>	<ul style="list-style-type: none"> <li>Minor regulatory action.</li> <li>Brief or no media/public attention.</li> </ul>

## STEP 2: Estimate Likelihood of Occurrence

Level	Description	Likelihood
D Common	Expected to occur several times during the life cycle of an operation or facility.	~50 times per year 25-100% chance
C Likely	Expected to occur once during the life cycle of an operation or facility.	~10 times per year <25% chance
B Unlikely	May happen less than once during the life cycle of an operation or facility.	One time in 10+ years <10% chance
A Rare	Remote or extremely remote chance of occurring.	One time in 100 years <1% chance

## STEP 3: Determine Risk Level

Consequence	Likelihood			
	A Rare	B Unlikely	C Likely	D Common
4 Critical	High Risk	High Risk	High Risk	High Risk
3 Serious	High Risk	High Risk	High Risk	High Risk
2 Moderate	High Risk	High Risk	High Risk	High Risk
1 Minor	High Risk	High Risk	High Risk	High Risk

Consequence x Likelihood = Risk level

## STEP 4: Assess Risk Level

**Extreme:** Activity under assessment cannot proceed until risk is reduced to a lower level.

**High:** Risk control measures must be implemented or OA VP & GM approval is required to allow assessed activity to proceed. Efforts to reduce risk to a MEDIUM level should be undertaken.

**Medium:** Complete assessed activity in this target risk zone.

**Low:** Risk is within tolerance.

## STEP 5: Take Action

Ensure all controls/mitigation measures and established procedures are understood and communicated prior to starting work. Obtain any approvals required.

Health and Safety Consequence Examples	Environment Consequence Examples
<p><b>Critical</b></p> <ul style="list-style-type: none"> <li>• <b>Life-threatening injury:</b> Requires immediate life-preserving rescue action. If action is not applied in an immediate fashion, would likely result in death. Usually requires the intervention of emergency response personnel. Some common examples include significant blood loss, damage to brain or spinal cord, use of CPR or AED, chest or abdominal trauma affecting vital organs and serious burns.</li> <li>• <b>Life-altering injury:</b> Results in permanent and significant loss of a major body part or organ function that permanently changes or disables that person's normal life. Some examples include significant head injuries, spinal cord injuries, paralysis, major amputations, catastrophic bone fractures and serious burns.</li> </ul>	<p><b>Critical</b></p> <ul style="list-style-type: none"> <li>• Persistent, severe environmental damage that will lead to a loss of commercial, recreational use or loss of natural resources over a wide area.</li> <li>• Spill resulting in pollution of a large part of river estuary and extensive clean-up and remediation measures.</li> <li>• Contamination to useable potable water source.</li> </ul>
<p><b>Serious</b></p> <ul style="list-style-type: none"> <li>• <b>Serious Injury:</b> An injury with an internally determined severity score of &gt;0.35; contact EH&amp;S for more information.</li> <li>• <b>Lost time incident:</b> Lost time incidents: are work-related injuries that render the injured person temporarily unable to perform any regular job or restricted work activity on any day (including normal days off, holidays, etc.) after the day on which the injury occurred.</li> </ul>	<p><b>Serious</b></p> <ul style="list-style-type: none"> <li>• Severe environmental damage that will require extensive measures to restore beneficial use to that environment.</li> <li>• Spill that impacts land areas (beaches, wetlands, etc.) requiring clean up operations.</li> <li>• Offsite groundwater contamination over an extensive area.</li> <li>• Significant deployment of spill response equipment.</li> <li>• Highly mobile groundwater contamination onsite or offsite.</li> <li>• Significant offsite soil impacts requiring extensive measures to remediate.</li> </ul>
<p><b>Moderate</b></p> <ul style="list-style-type: none"> <li>• <b>Restricted work:</b> Occurs when, as the result of a work-related injury, a physician or other licensed health care professional (whose practice includes medical diagnosis) recommends that the employee not perform one or more of the routine functions of his or her job or not work the full workday that he or she would otherwise have been scheduled to work.</li> <li>• <b>Medical aid:</b> Management and care of an injured or ill worker by a physician or other licensed health care professional for the purpose of managing a work-related injury or illness/exposure, that involves any treatment beyond first aid. Some examples include removal of foreign bodies embedded in the eye, physical therapy or chiropractic treatment and an injury requiring sutures.</li> </ul>	<p><b>Moderate</b></p> <ul style="list-style-type: none"> <li>• Limited environmental damage that will persist or require clean-up.</li> <li>• Spill that migrates off lease requiring clean up.</li> <li>• Spill that results in onsite groundwater contamination.</li> <li>• Observed off-site effects or damage (e.g., fish kill or damaged vegetation).</li> <li>• Significant onsite soil impacts requiring remediation.</li> </ul>
<p><b>Minor</b></p> <ul style="list-style-type: none"> <li>• Work activities with only a limited injury potential (e.g., first aid).</li> <li>• <b>First aid:</b> Common examples include using wound coverings such as bandages, Band-Aids™, gauze pads. Also, cleaning, flushing or soaking wounds on the surface of the skin and using hot or cold therapy.</li> </ul>	<p><b>Minor</b></p> <ul style="list-style-type: none"> <li>• Localized and short term impacts but no lasting effect.</li> <li>• Small spill that is contained on lease.</li> </ul>
Considerations for Using the Operational Risk Matrix	
<p><b>Field-based application</b>—use the operational risk matrix when:</p> <ul style="list-style-type: none"> <li>• You need to deviate from an established procedure.</li> <li>• Swapping or changing out equipment or parts with something other than an “identical replacement” (different make, model, capacity, function).</li> <li>• Unplanned simultaneous operations are required.</li> <li>• Unplanned or unanticipated event occurs that result in a STOP the job.</li> <li>• A short service worker is brought on to a job or task.</li> <li>• You are uncertain as to your work responsibilities.</li> <li>• A job site analysis or safe work permit does not cover the task or job step.</li> </ul>	<p><b>Office-based application</b>—use the operational risk matrix when:</p> <ul style="list-style-type: none"> <li>• Assessing or revising a development plan.</li> <li>• Designing or revising a procedure (P&amp;A, drilling, completions etc.).</li> <li>• Considering acquisitions or divestitures.</li> <li>• Conducting a formal or informal management of change.</li> <li>• Performing process hazard analysis, design review, P&amp;ID reviews.</li> <li>• Developing EH&amp;S and regulatory compliance strategies.</li> </ul>

**Health and Safety**—focused on acute and chronic health effects along with serious injury and fatality and minor injury avoidance.

**Environment**—focused on environmental effects and damage related to air/land/water/wildlife, resulting from a spill, release or contamination from Ovintiv work activities.

**Asset (\$)**—focused on tangible direct/indirect consequence on equipment or property or other damage to repair/replace.

**Regulatory**— focused on escalating to the magnitude of regulatory/legal action against the company and/or negative media/public attention.

Page  
Redacted:  
Personal  
Information

This page intentionally left blank

---

## EXTERNAL EMERGENCY NOTIFICATION FLOWCHART

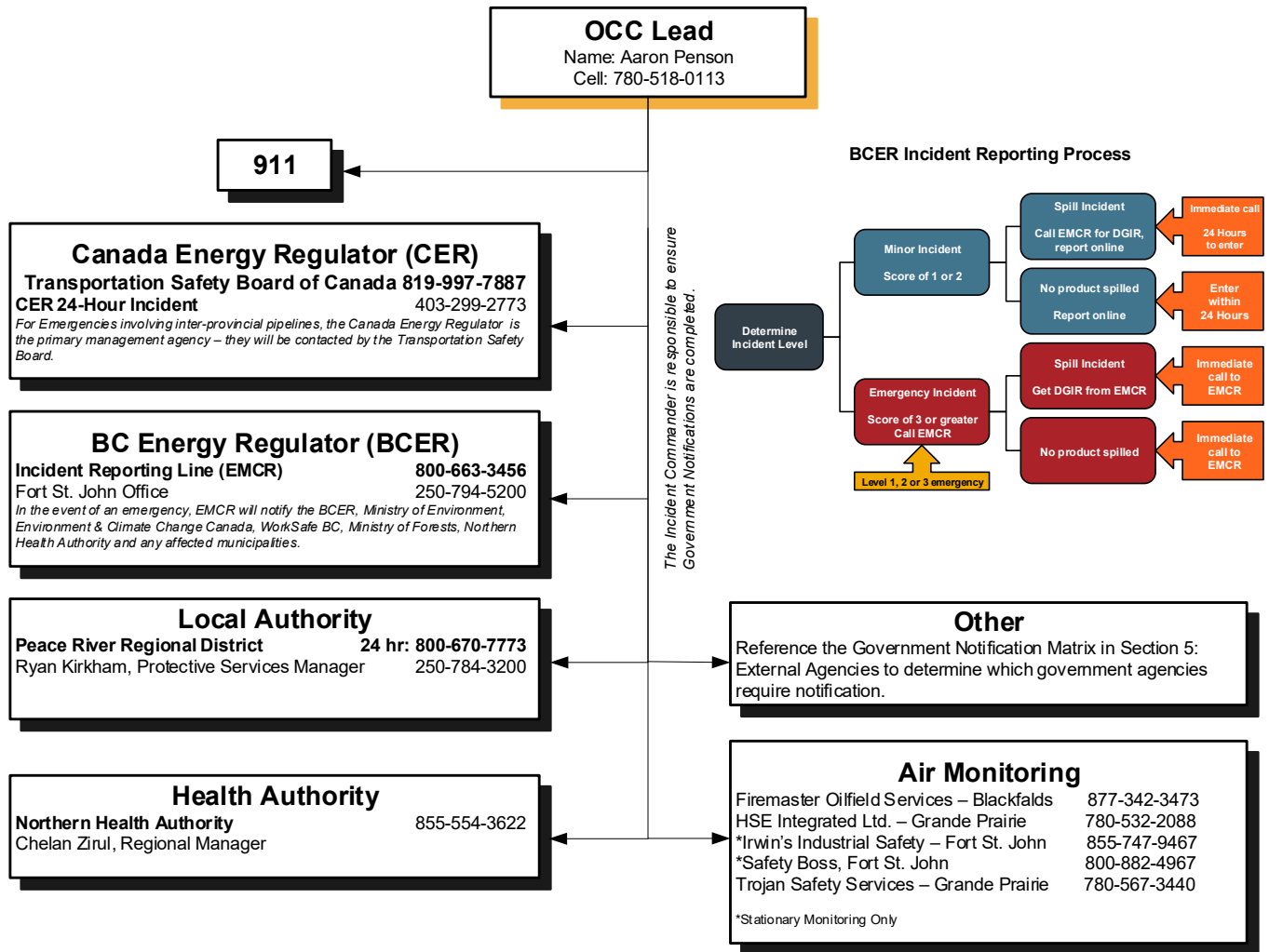

Refer to Section 5: External Agencies for the Government Notification Matrix, Provincial Lead and Supporting Agencies and Federal Agencies required to be contacted or notified.

- Ovintiv
- External Notification
- External Agencies

Note: After Initial Notifications are complete, please reference Step 4 – Incident Briefing and begin building the initial Organizational Structure (pg 3) within the ICS 201 Incident Briefing form.

# STEP 3 – EXTERNAL NOTIFICATION



This Page Intentionally Left Blank

---



Current and Planned Objectives:	
Priorities: (1) Life Safety (2) Incident Stabilization (3) Environment & Property	
<b>1. Ensure Safety of Citizens and Response Personnel:</b>	<b>4. Minimize Economic Impacts:</b>
<input type="checkbox"/> 1a. Identify hazard(s) of released product.	<input type="checkbox"/> 4a. Consider tourism and local economic impacts.
<input type="checkbox"/> 1b. Establish site control (hot zone, warm zone, cold zone, & security).	<input type="checkbox"/> 4b. Protect public and private assets, as resources permit.
<input type="checkbox"/> 1c. Establish an Emergency Response Zone and Initiate Public Safety Actions.	<input type="checkbox"/> 4c. Establish damage claims process.
<input type="checkbox"/> 1d. Consider evacuations if needed.	<b>5. Keep Stakeholders and Public Informed of Response Activities:</b>
<input type="checkbox"/> 1e. Establish aircraft restrictions.	<input type="checkbox"/> 5a. Provide forum to obtain stakeholder input and concerns.
<input type="checkbox"/> 1f. Monitor air in impacted areas	<input type="checkbox"/> 5b. Provide stakeholders with details of response actions.
<input type="checkbox"/> 1g. Develop site safety plan for personnel and ensure safety briefings are conducted.	<input type="checkbox"/> 5c. Identify stakeholder concerns and issues, and address as practical.
<b>2. Control the Source of the Release:</b>	<input type="checkbox"/> 5d. Provide timely safety announcements.
<input type="checkbox"/> 2a. Complete emergency shutdown.	<input type="checkbox"/> 5e. Conduct regular news briefings.
<input type="checkbox"/> 2b. Conduct firefighting.	<input type="checkbox"/> 5f. Conduct public meetings, as appropriate.
<input type="checkbox"/> 2c. Initiate temporary repairs.	
<b>3. Manage a Coordinated Response Effort:</b>	
<input type="checkbox"/> 3a. Complete or confirm notifications.	
<input type="checkbox"/> 3b. Establish a unified command organization and facilities (command post, etc.).	
<input type="checkbox"/> 3c. Ensure mobilization and tracking of resources and account for personnel and equipment.	
<input type="checkbox"/> 3d. Complete documentation.	
Current and Planned Actions, Strategies and Tactics:	
Time:	Actions:
HHMM	
HHMM	
HHMM	
HHMM	
HHMM	
HHMM	
HHMM	
HHMM	
HHMM	

**Current Organizational Structure: (draw in current response structure)\***

*\* This is a condensed Organizational Chart to account for all currently responding personnel during the Initial Response.*

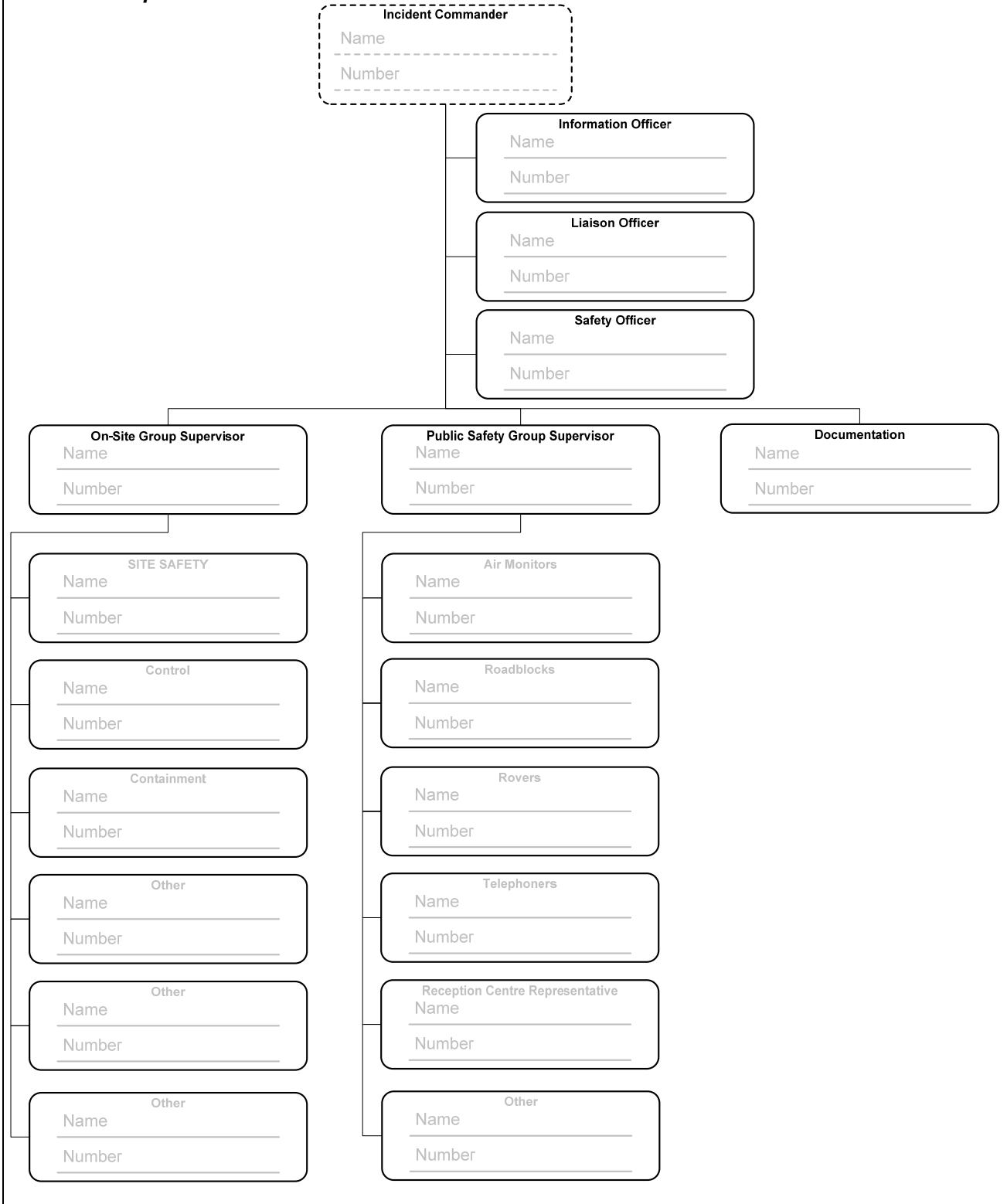

```

graph TD
    IC[Incident Commander  
Name _____  
Number _____]
    IO[Information Officer  
Name _____  
Number _____]
    LO[Liaison Officer  
Name _____  
Number _____]
    SO[Safety Officer  
Name _____  
Number _____]
    OSGS[On-Site Group Supervisor  
Name _____  
Number _____]
    PSGS[Public Safety Group Supervisor  
Name _____  
Number _____]
    DOC[Documentation  
Name _____  
Number _____]
    
    IC --- IO
    IC --- LO
    IC --- SO
    IC --- OSGS
    IC --- PSGS
    IC --- DOC
    
    OSGS --- SS[SITE SAFETY  
Name _____  
Number _____]
    OSGS --- C[Control  
Name _____  
Number _____]
    OSGS --- CO[Containment  
Name _____  
Number _____]
    OSGS --- O1[Other  
Name _____  
Number _____]
    OSGS --- O2[Other  
Name _____  
Number _____]
    OSGS --- O3[Other  
Name _____  
Number _____]
    
    PSGS --- AM[Air Monitors  
Name _____  
Number _____]
    PSGS --- RB[Roadblocks  
Name _____  
Number _____]
    PSGS --- RO[Rovers  
Name _____  
Number _____]
    PSGS --- TEL[Telephoners  
Name _____  
Number _____]
    PSGS --- RCR[Reception Centre Representative  
Name _____  
Number _____]
    PSGS --- O4[Other  
Name _____  
Number _____]
    
    DOC --- DOC
  
```

Note: Refer to ICS 207 Incident Organization Chart in Section 6: Forms (Blue Tab) for full command structure.



# Step 4 – Incident Briefing



## Core Emergency Response Plan

Site Safety and Hazard Control Analysis	
<b>Site Control</b>	
1. Is Site Control set-up? <input type="checkbox"/> Yes <input type="checkbox"/> No	2. Is there an On-Scene Command Post? <input type="checkbox"/> Yes <input type="checkbox"/> No If so, where?
3. Have all personnel been accounted for? <input type="checkbox"/> Yes <input type="checkbox"/> No <input type="checkbox"/> Don't Know	Injuries: _____ Unaccounted: _____ Fatalities: _____ Trapped: _____
4. Are observers involved or rescue attempts planned? Observers: <input type="checkbox"/> Yes <input type="checkbox"/> No Rescuers: <input type="checkbox"/> Yes <input type="checkbox"/> No	5. Are Decon areas setup? <input type="checkbox"/> Yes <input type="checkbox"/> No If so, where?
<b>Hazard Identification, immediate signs of: (if yes, explain in remarks)</b>	
1. Electrical line(s) down or overhead? <input type="checkbox"/> Yes <input type="checkbox"/> No	2. Unidentified liquid or solid products visible? <input type="checkbox"/> Yes <input type="checkbox"/> No
3. Wind direction across incident: <input type="checkbox"/> Towards your position Wind Speed: <input type="checkbox"/> Away from your position	4. Is a safe approach possible? <input type="checkbox"/> Yes <input type="checkbox"/> No
5. Odours or smells? <input type="checkbox"/> Yes <input type="checkbox"/> No	6. Vapours visible? <input type="checkbox"/> Yes <input type="checkbox"/> No
7. Holes, ditches, fast water, cliffs, etc. nearby? <input type="checkbox"/> Yes <input type="checkbox"/> No	8. Fire, sparks, sources of ignition nearby? <input type="checkbox"/> Yes <input type="checkbox"/> No
9. Is local traffic a potential problem? <input type="checkbox"/> Yes <input type="checkbox"/> No	10. Product placards, colour codes visible? <input type="checkbox"/> Yes <input type="checkbox"/> No
11. Other Hazards? <input type="checkbox"/> Yes <input type="checkbox"/> No	12. As you approach the scene from the upwind side, do you note a change in the status of any of the above? <input type="checkbox"/> Yes <input type="checkbox"/> No
13. Remarks:	
<b>Hazard Mitigation: have you determined the necessity for any of the following?</b>	
1. Entry Objectives:	
2. Warning sign(s), barriers, colour codes in place? <input type="checkbox"/> Yes <input type="checkbox"/> No	
3. Hazardous material being monitored? <input type="checkbox"/> Yes <input type="checkbox"/> No 3a. Sampling equipment: 3b. Sampling location(s): 3c. Sampling frequency: 3d. Peak reading: 3e. Personal exposure monitoring:	
4. Protective gear / level: 4b. Respirators 4d. Boots:	4a. Gloves: 4c. Clothing: 4e. Chemical cartridge change frequency:
5. Decon 5a. Instructions: 5b. Decon equipment and materials:	
6. Emergency escape route established? <input type="checkbox"/> Yes <input type="checkbox"/> No Route?	
7. Field responders briefed on hazards? <input type="checkbox"/> Yes <input type="checkbox"/> No	
8. Remarks:	
Protective Zones: record initial control perimeters (see Figure 1)	



# Public Protection Measures Flowchart

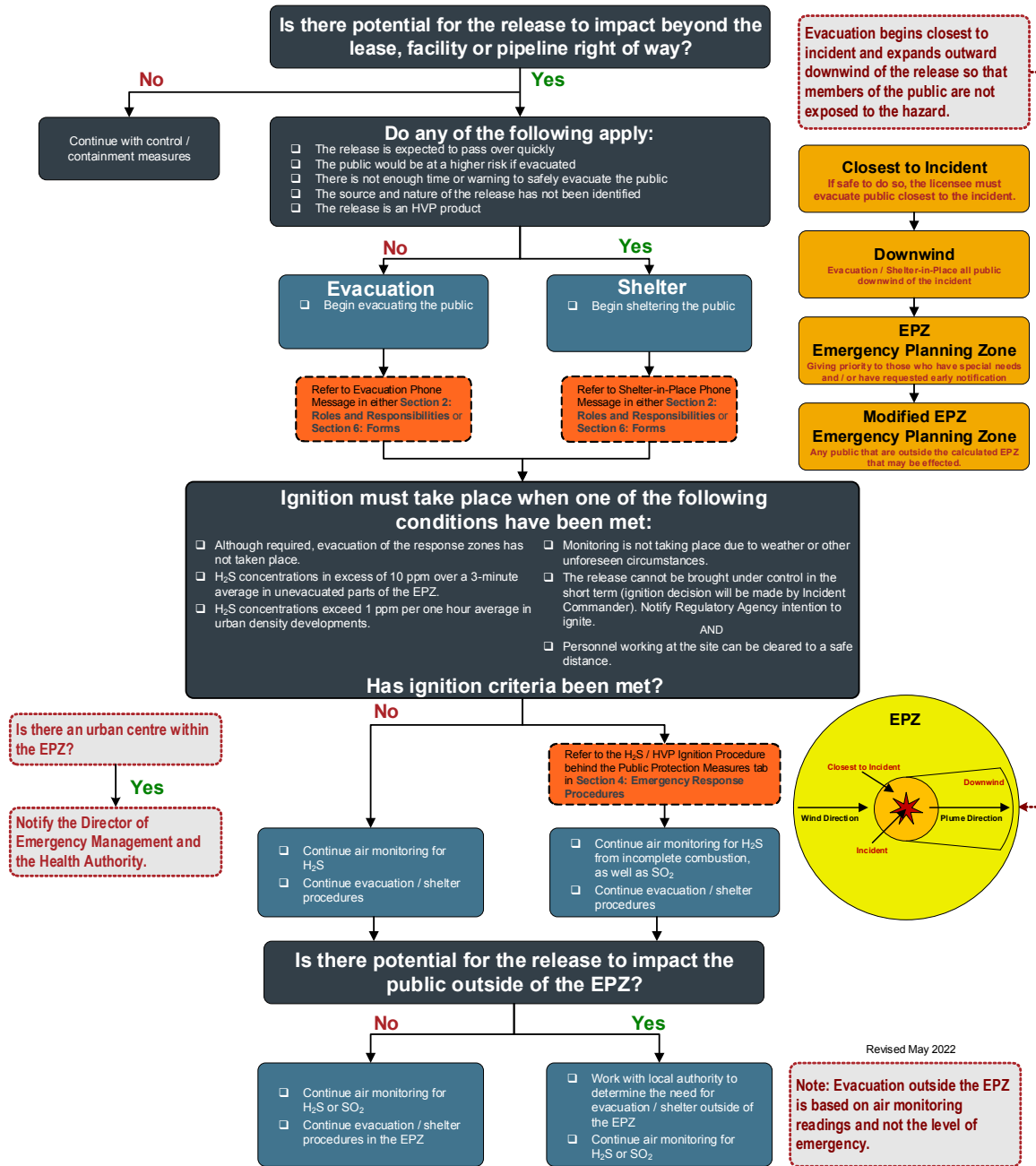

## Notification and Evacuation Requirements Outside of the EPZ

For a sour gas release, the licensee must continuously assess and act on the need to expand the evacuation area based on the monitored levels of H<sub>2</sub>S and SO<sub>2</sub>. In the absence of monitored readings, responders should advise the residents to Shelter-in-Place.

H <sub>2</sub> S Requirements		SO <sub>2</sub> Requirements	
1-10 ppm	Individuals who requested notification so that they can voluntarily evacuate before any exposure to H <sub>2</sub> S or SO <sub>2</sub> must be notified.	1-5 ppm	Individuals who requested notification so that they can voluntarily evacuate before any exposure to H <sub>2</sub> S or SO <sub>2</sub> must be notified.
10 ppm and above (1-hour average)	Local conditions must be assessed and all persons must be advised to evacuate and/or shelter.	5 ppm and above	Local conditions must be assessed and all persons must be advised to evacuate and/or shelter.
<p>Note: H<sub>2</sub>S Evacuation Level – when downwind monitoring at the nearest unevacuated residence, outside the Hazard Planning Zone, indicates a level of 10 ppm, evacuation procedures will be initiated if safe to do so.</p>			

This page is intentionally left blank

---

# Section 2: Roles and Responsibilities

## **FIELD RESPONSE TEAM**

### **KEY RESPONSE PERSONNEL**

GENERAL SAFETY EQUIPMENT AND RESOURCE LISTS

### **KEY RESPONSE PERSONNEL**

COMMAND STAFF ROLES & RESPONSIBILITIES

### **KEY RESPONSE PERSONNEL, CONTINUED**

COMMAND STAFF ROLES & RESPONSIBILITIES, CONTINUED

### **FIELD RESPONSE TEAM - COMMAND STAFF**

COMMAND STAFF ROLES CHART

### **FIELD RESPONSE TEAM - GENERAL STAFF**

OPERATIONS SECTION ROLES CHART

PLANNING SECTION ROLES CHART

LOGISTICS SECTION ROLES CHART

FINANCE / ADMIN SECTION ROLES CHART

### **FIELD RESPONSE TEAM - PUBLIC SAFETY**

PUBLIC SAFETY ROLES CHART

AIR MONITORS MODULE

RECEPTION CENTRE REP MODULE

ROADBLOCKS MODULE

ROVERS MODULE

TELEPHONERS MODULE

### **ONGOING RESPONSE**

PLANNING "P"

5 STEP ONGOING RESPONSE GUIDE

OBJECTIVES MEETING

TACTICS MEETING

PLANNING MEETING

OPERATIONS BRIEFING

---

This Page is Intentionally Left Blank

---

# FIELD RESPONSE TEAM

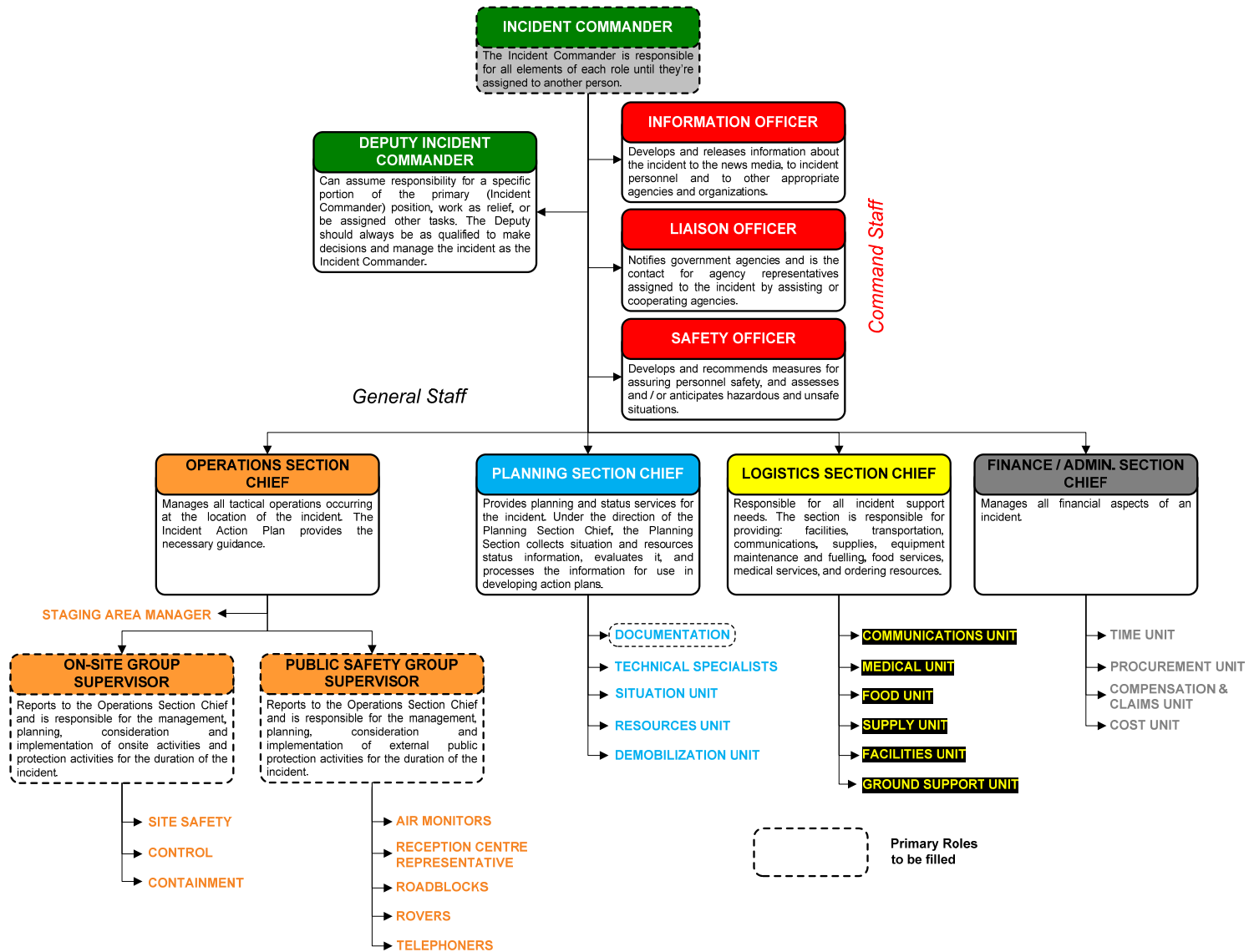

EMERGENCY RESPONSE ORGANIZATIONAL CHART

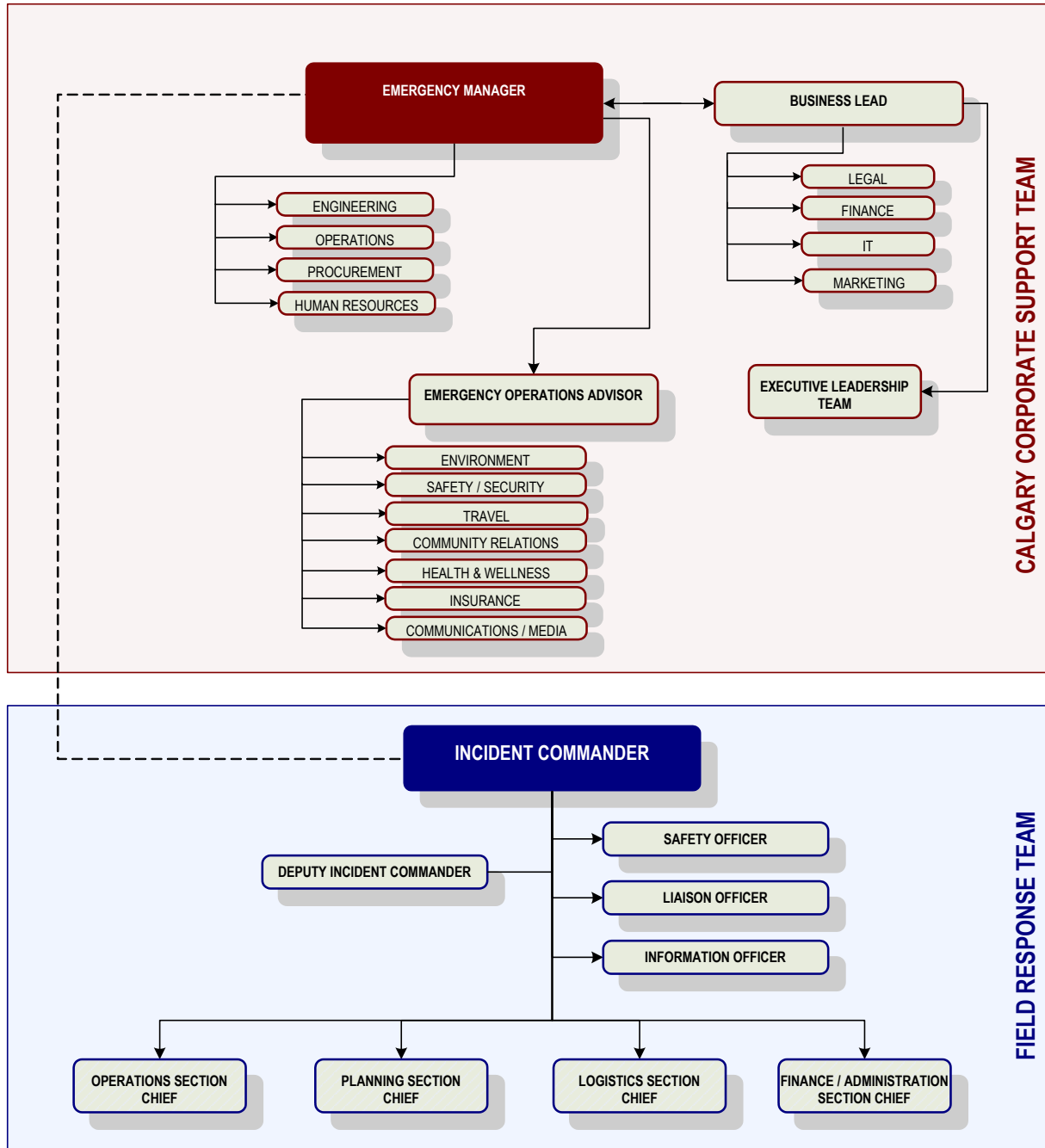

Legend

- Communication
- Command

\* The detailed role descriptions for the Field Response Team can be found in the applicable field ERPs located at Ovintiv's Calgary Office.

## KEY RESPONSE PERSONNEL

The following individuals are *likely* to fill the key response roles identified:

<b>COMMAND STAFF</b>	<b>Incident Commander</b>	OCC Lead Drilling Superintendent (Back Up Incident Commander)
<b>ON-SITE</b>	<b>On-Site Group Supervisor</b>	Lead Field Operators Please see the AREA SPECIFIC INFORMATION (white tabs) for a list of Lead Operators.
	<b>Trained in Ignition (H<sub>2</sub>S &amp; HVP)</b>	Emergency Manager Operations Chief / Incident Commander
<b>PUBLIC SAFETY</b>	<b>Public Safety Group Supervisor</b>	Public Protection Chief Lead Field Operators
	<b>Air Monitors / Roadblock / Rovers</b>	Field Operators Please see the AREA SPECIFIC INFORMATION (white tabs) for a list of Area Operators.
	<b>Telephoners</b>	Operations Technician
	<b>Reception Centre Representative</b>	Community Relations Advisor Please see the or AREA SPECIFIC INFORMATION (white tabs) for a list of Area Operators.

*Please refer to the AREA SPECIFIC INFORMATION (white tabs) for the full list of personnel and their contact information.*

## GENERAL SAFETY EQUIPMENT AND RESOURCE LISTS

### Operator, Truck & Other Safety Equipment

Each operator is required to drive a suitable vehicle (4x4 truck) for their service areas and should carry the following equipment: 20-30lb fire extinguisher, vehicle emergency roadside kit, cell phone and a 4 head monitor.

Refer to AREA SPECIFIC INFORMATION SECTION (white tabs) for further details on specific air monitoring equipment, back-up communication methods, ignition and roadblock kit contents as well as their locations, specialty fire-fighting equipment and/or service companies and their contact information for if the aforementioned equipment is not available.

This Page is Intentionally Left Blank

---

---

## KEY RESPONSE PERSONNEL

### COMMAND STAFF ROLES & RESPONSIBILITIES

#### EMERGENCY MANAGER

*Provides Corporate support with resources and business decisions*

---

##### Level 1 Emergency

- DOCUMENT all activities on Time and Event Log
  - Establish communications with **Emergency Operations Advisor** and **Business Lead** to discuss safety and technical support requirements
  - Provide assistance with regulatory agency notifications if requested
- 

##### Level 2 & 3 Emergency

- DOCUMENT all activities
  - Monitor all phases of the emergency control operations
  - Liaison with the **Incident Commander** regarding Ignition
  - Direct the **Incident Commander** to implement Ignition immediately the Ignition Criteria are met
  - Notify and maintain contact with appropriate government agencies' head or supplemental offices
  - Update **Emergency Operations Advisor** and **Business Lead** and ensure technical, operational and business decision support is provided
  - Ensure that the **Senior Management Team** is advised of the situation by the **Business Lead**
  - Coordinate field level media support
  - Update the **Emergency Operations Advisor** and **Business Lead**, who will activate the Senior Management Team if not already initiated, and provide additional technical, operational and media support
  - Update and maintain contact with the appropriate government agencies
  - Note: for a **Level 1** Emergency, the **Emergency Manager** or the **Incident Commander**, in consultation with the **BCER** are the only Ovintiv representatives with the authority to terminate an emergency.
  - For a **Level 2 or 3** Emergency, only the **Emergency Manager**, in consultation with the **BCER** and the **local and/or provincial disaster service authorities**, has the authority to terminate an emergency.
-

---

## KEY RESPONSE PERSONNEL, CONTINUED

### COMMAND STAFF ROLES & RESPONSIBILITIES, CONTINUED

#### EMERGENCY OPERATIONS ADVISOR (On Call Position)

*Provides Corporate support with resources and business decisions*

---

##### Level 1 Emergency

- DOCUMENT all activities on Time and Event Log
  - Establish communications with **Emergency Manager** and **Incident Commander**
  - Make the **Incident Commander** aware of services and expertise available to assist
- 

##### Level 2 & 3 Emergency

- DOCUMENT all activities
  - Identify government and other agencies related to the incident, and ensure that notifications are done, and maintained
  - Provide specialized resources and technical expertise in the areas of environment, media, community relations, and insurance
  - Identify affected contractors, and confirm whether the contractors' head office(s) have been notified
  - Coordinate meetings between government agencies and Company personnel as required
  - Notify corporate level of environment, community relations, insurance, etc. and advise of the situation
  - Ensure all documentation is being collected at all response levels
- 

## BUSINESS LEAD

---

##### Level 1, 2 & 3 Emergency

- DOCUMENT all activities on Time and Event Log
  - If a level of emergency is skipped, ensure procedures for a lower level emergency have been completed
  - Advise and update the **Senior Management Team** if any of the crisis notification criteria are met
  - Reassign resources within the business unit, (e.g., financial, physical, technical) to support the response
  - Assess Corporate exposure and participate in strategic planning
  - Redirect all media inquiries to the Media Spokesperson
- 

##### Post-Incident

- Notify the **Senior Management Team** of the emergency call down status
  - Instruct any business unit responders to forward their related documentation to the Emergency Operations Advisor in preparation of the Post-Incident reporting
-

# Command Staff Roles

Incident Commander	Deputy Incident Commander	Information Officer	Liaison Officer	Safety Officer
<p>The <b>Incident Commander</b> is in charge of overall management of the incident and must be fully qualified to manage the incident. As incidents grow in size or complexity, a more highly qualified <b>Incident Commander</b> may be assigned by the company.</p> <p><b>Note:</b> The highest ranking authority arriving at the site of the incident (first on-scene) becomes the <b>Incident Commander</b> and establishes command and control. The first on-scene will remain the <b>Incident Commander</b> until there is formal transfer of command to a more senior company employee and / or qualified personnel.</p>	<p>The <b>Deputy Incident Commander</b> may assume responsibility for a specific portion of the primary position, work as relief, or be assigned other tasks. The <b>Deputy</b> should always be as qualified to make decisions and manage the incident as the <b>Incident Commander</b>.</p>	<p>The <b>Information Officer</b> is responsible for developing and releasing information about the incident to the news media, to incident personnel and to other appropriate agencies and organizations.</p>	<p>The <b>Liaison Officer</b> is responsible for notifying government agencies and is the contact for agency representatives assigned to the incident by assisting or cooperating agencies.</p>	<p>The <b>Safety Officer</b> develops and recommends measures for assuring personnel safety, and assesses and / or anticipates hazardous and unsafe situations.</p>
<p><b>Initial Response - *Refer to the 5 Step Initial Response Guide in Section 1: Initial Response*</b></p> <p><b>Step 1: Level of Emergency</b></p> <ul style="list-style-type: none"> <li><input type="checkbox"/> If necessary, investigate and confirm the emergency. If the incident involves a release of sour product, the investigation should be conducted in teams of two. Take appropriate safety precautions (PPE, SCBA, etc.). Ensure personal safety at all times.</li> <li><input type="checkbox"/> Determine the Level of Emergency using the BCER Incident Classification Matrix for BC or AER's Assessment Matrix for Classifying Incidents for all other provinces (e.g. Alert/Minor, Level 1, 2, 3) found in <b>Section 1: Initial Response</b> or using the Emergency Assessment SmartPhone App. (Search H<sub>2</sub>Safety or Emergency Assessment in the App Store).</li> </ul> <p><b>Step 2: Internal Notification</b></p> <ul style="list-style-type: none"> <li><input type="checkbox"/> Follow the Internal Emergency Notification Flowchart outlined in Section 1: Initial Response to contact required field resources. Refer to the <b>Section 2: Roles and Responsibilities / Response Team Phone List</b>. Relay the information from the A1 Initial Notification Form. Mobilize internal resources to the site, to the Incident Command Post (ICP) or place them on standby as required.</li> <li><input type="checkbox"/> Contact required company resources and communicate the level of emergency. Refer to <b>Section 2: Roles and Responsibilities / Response Team Phone List</b>.</li> </ul> <p><b>Step 3: External Notification</b></p> <ul style="list-style-type: none"> <li><input type="checkbox"/> Follow the External Emergency Notification Flowchart in <b>Section 1: Initial Response</b> for communication structure and the Provincial Notification Matrix in <b>Section 5: External Agencies</b> to determine which external agencies need to be notified. Reference <b>Section 5: External Agencies</b> and the <b>Area Specific Information</b> for the location of the incident.</li> </ul> <p><b>Step 4: Incident Briefing</b></p> <ul style="list-style-type: none"> <li><input type="checkbox"/> The following positions are always filled regardless of the size of the incident: <b>Incident Commander, On-Site Group Supervisor</b> and <b>Documentation</b>.</li> <li><input type="checkbox"/> Assess the situation, identify the incident source, and consider how to stop the source. Carry out a site assessment that includes the following: identify hazardous materials, evaluate risk to workers and the public, determine the potential for the incident to escalate, identify safety concerns, determine which other company's facilities are involved.</li> <li><input type="checkbox"/> Detail and prioritize the objectives for the next operational period taking into consideration the <b>priorities of (1) Life Safety, (2) Incident Stabilization, (3) Property &amp; Environment</b> using the ICS 201 Incident Briefing Form.</li> <li><input type="checkbox"/> Assign other positions as required to meet the identified objectives. Review and complete the ICS 207 Incident Organization Chart in <b>Section 6: Forms</b>. Depending on the scale of emergency, all positions may not be assigned. The <b>Incident Commander</b> assumes responsibility for all unassigned roles until personnel have been assigned to them.</li> <li><input type="checkbox"/> Conduct a role review with each of the positions above to ensure they clearly understand their roles and responsibilities.</li> <li><input type="checkbox"/> Develop detailed plans of action (strategies) to achieve the objectives and determine what tactics and resources are required to implement the strategies (oil spill services, safety services, etc.).</li> <li><input type="checkbox"/> Activate the Incident Command Post (ICP). Refer to the <b>Appendices</b> for Incident Command Post activation guidelines.</li> <li><input type="checkbox"/> Ensure the <b>Planning Section</b> posts and updates the status board with incident details.</li> </ul> <p><b>Step 5: Public Safety</b></p> <ul style="list-style-type: none"> <li><input type="checkbox"/> Determine the size of the Emergency Planning and Response Zones around the incident. Refer to the EPZ calculation tables and map in <b>Area Specific Information</b>.</li> <li><input type="checkbox"/> Use the Public Protection Measures Flowchart located in <b>Section 1: Initial Response</b> to assist with determining if evacuation / shelter / ignition are required.</li> <li><input type="checkbox"/> Ensure the affected public are contacted and advised to shelter or evacuate as required.</li> <li><input type="checkbox"/> Establish <b>Air Monitoring, Reception Centre Representatives, Roadblocks, Rovers</b>, and <b>Telephoners</b> as required.</li> </ul> <p><b>Ongoing Response - *Refer to the Five Step Ongoing Response Guide in Section 2: Ongoing Response*</b></p> <ul style="list-style-type: none"> <li><input type="checkbox"/> Establish a method to track responders and resources to ensure they are accounted for at all times.</li> <li><input type="checkbox"/> Monitor implementation of IAP and revise as the situation dictates. Prepare for next operational period.</li> <li><input type="checkbox"/> Support the <b>Operations Section Chief</b> in the preparation of an incident control and containment action plan.</li> <li><input type="checkbox"/> Ensure each section chief has adequate staff, is not violating span of control and clearly understands the roles and responsibilities.</li> <li><input type="checkbox"/> Conduct frequent Command Staff and General Staff meetings.</li> <li><input type="checkbox"/> If transfer of command occurs, an incident status briefing must take place. Provide all documentation and review situation status, objectives and priorities, current organization and resources, facilities, communications plan, concerns and introductions to staff.</li> <li><input type="checkbox"/> As the emergency is brought under control, the decision to downgrade the level and/or stand down the emergency will be based on air monitoring readings in consultation with the <b>Incident Commander</b> and the applicable government regulator.</li> <li><input type="checkbox"/> The <b>Demobilization Unit</b> will develop and implement objectives/strategies for demobilization.</li> </ul>	<ul style="list-style-type: none"> <li><input type="checkbox"/> If no scribe has been assigned to the <b>Incident Commander</b>, support the <b>Incident Commander</b> by documenting details of the emergency, focusing on activities and decisions made.</li> <li><input type="checkbox"/> Record, update and maintain a chronological summary of the incident including: <ul style="list-style-type: none"> <li><input type="checkbox"/> Names of personnel in each assigned position and their location</li> <li><input type="checkbox"/> Control and containment measures</li> <li><input type="checkbox"/> Environmental monitoring information</li> <li><input type="checkbox"/> Injuries / deaths / missing persons</li> <li><input type="checkbox"/> Phone calls</li> <li><input type="checkbox"/> Actions and decisions</li> <li><input type="checkbox"/> Status of the public protection actions</li> </ul> </li> <li><input type="checkbox"/> Manage the flow of traffic to and communication with the <b>Incident Commander</b> so that he can focus on managing the incident.</li> <li><input type="checkbox"/> Conduct status update meetings.</li> <li><input type="checkbox"/> Provide status to head office.</li> <li><input type="checkbox"/> Deal with some day-to-day decision making.</li> <li><input type="checkbox"/> Assume duties of the <b>Incident Commander</b>, if required.</li> <li><input type="checkbox"/> Maintain communication with the <b>Incident Commander</b>.</li> </ul> <div style="border: 2px solid red; padding: 5px; margin-top: 10px;"> <p style="text-align: center; color: red; font-weight: bold;">Important</p> <p>Prior to beginning any activities, each person in a role must:</p> <ul style="list-style-type: none"> <li><input type="checkbox"/> Obtain a completed ICS 201 Incident Briefing and ICS 207 Incident Organization Chart from the <b>Incident Commander</b>.</li> </ul> <p>Throughout the duration of the incident, each person in a role must:</p> <ul style="list-style-type: none"> <li><input type="checkbox"/> Chronologically document all actions, decisions, contacts and requests on an ICS 214 Activity Log. Copies can be found in <b>Section 6: Forms</b>.</li> </ul> <p>After the incident is over, each person in a role must:</p> <ul style="list-style-type: none"> <li><input type="checkbox"/> Assist with post-incident activities.</li> </ul> <p style="text-align: center; color: red; font-weight: bold;">All forms referenced can be found in Section 6: Forms</p> </div>	<ul style="list-style-type: none"> <li><input type="checkbox"/> Receive incident briefing from the <b>Incident Commander</b> before contacting external agencies.</li> <li><input type="checkbox"/> Prepare regular status updates that will be provided to internal company personnel to keep them apprised of the situation.</li> <li><input type="checkbox"/> Identify and document any media involvement that has already taken place</li> <li><input type="checkbox"/> If the media statement hasn't yet been prepared ensure that the generic media statement from the ERP is communicated and being used in the field.</li> <li><input type="checkbox"/> Assist head office with the preparation of a preliminary media statement if required using the Preliminary Media Statement form.</li> <li><input type="checkbox"/> Document all communications with the media using the Media Contact Log.</li> <li><input type="checkbox"/> Develop a detailed media strategy for the incident.</li> <li><input type="checkbox"/> Designate and prepare media briefing rooms away from the Incident Command Post.</li> <li><input type="checkbox"/> Organize tours and photo opportunities if required.</li> <li><input type="checkbox"/> Maintain communication with the <b>Incident Commander</b>.</li> <li><input type="checkbox"/> Media releases must be coordinated with applicable regulatory agency.</li> <li><input type="checkbox"/> If necessary, coordinate with and use broadcast media to notify residents in the hazard area.</li> <li><input type="checkbox"/> Work with Communications / Media to develop a communications plan that includes establishing protocols for responders and all company personnel as required to ensure incident information remains confidential (i.e. restriction on cell phone usage for photography, social media, speaking to the media, etc.).</li> </ul>	<ul style="list-style-type: none"> <li><input type="checkbox"/> Complete Regulatory First Call Communication Form. <span style="border: 1px solid black; padding: 2px;">Form A3</span></li> <li><input type="checkbox"/> Refer to Section 5: External Agencies for the Government Notification Matrix. Notify as soon as possible and provide status updates at agreed upon intervals to: <ul style="list-style-type: none"> <li><input type="checkbox"/> Government regulator</li> <li><input type="checkbox"/> Local authorities (counties, cities, towns, MDs, RDs, First Nations Reserves, etc.)</li> <li><input type="checkbox"/> Health authority</li> <li><input type="checkbox"/> Environment</li> <li><input type="checkbox"/> Provincial emergency management organization</li> <li><input type="checkbox"/> Other agencies</li> </ul> </li> <li><input type="checkbox"/> Keep track of all government correspondence using the Government Agency Contact Log. <span style="border: 1px solid black; padding: 2px;">Form C3</span></li> <li><input type="checkbox"/> Obtain cooperating and assisting agency information that includes: contact information, radio frequencies, cooperative agreements, equipment type, number of personnel, condition of equipment and personnel, agency constraints, etc.</li> <li><input type="checkbox"/> Conduct appropriate periodic briefings to keep agencies informed of planning actions.</li> <li><input type="checkbox"/> Coordinate with any government agency representatives attending the ICP or REOC.</li> <li><input type="checkbox"/> Coordinate with mutual aid groups.</li> </ul>	<ul style="list-style-type: none"> <li><input type="checkbox"/> Ensure the site is evacuated if unsafe.</li> <li><input type="checkbox"/> Initiate rescue plans if safe to do so.</li> <li><input type="checkbox"/> Review the Incident Action Plan to identify and correct any potential occupational and health hazards.</li> <li><input type="checkbox"/> Ensure work / rest guidelines are followed.</li> <li><input type="checkbox"/> Continuously monitor workers for exposure to ensure they are wearing the required PPE.</li> <li><input type="checkbox"/> Take appropriate action to mitigate or eliminate unsafe conditions, operations, or hazards.</li> <li><input type="checkbox"/> Immediately stop any unsafe practices.</li> <li><input type="checkbox"/> Conduct a general inspection of the facilities, food services and sanitation services soon after they become operational and follow up on a periodic basis throughout the incident for compliance to all health and safety standards. Provide a report of deficiencies.</li> <li><input type="checkbox"/> Document both safe and unsafe acts, corrective actions taken on the scene, accidents or injuries, and ways to improve safety on future incidents.</li> <li><input type="checkbox"/> Investigate accidents that have occurred within the incident area.</li> <li><input type="checkbox"/> Identify "Hot Zone" and declare when responders may enter it.</li> <li><input type="checkbox"/> Ensure that responders inside the "Hot Zone" are accounted for and initiate search if required.</li> <li><input type="checkbox"/> Prepare a site-specific health and safety plan.</li> </ul>

All team members are located at the Incident Command Post (ICP), unless otherwise noted.

Revised March 2023

**Escalate, Downgrade or Stand-Down Levels of Emergency:** As the emergency is brought under control, the decision to downgrade the level and/or stand down the emergency will be based on air monitoring readings in consultation with the **Incident Commander** and the applicable government regulator. All affected persons and the media must be kept informed of the status of an emergency. **Emergency Follow-up:** Once the emergency is over, the area residents, transients, industrial users, involved government agencies, and any individual notified will be informed of the stand-down by the **Information Officer** or **Public Safety Group Supervisor**.

# General Staff Roles – Operations Section

Operations Section Chief	On-Site Group Supervisor	Staging Area Manager	Site Safety	Control	Containment
<p>The <b>Operations Section Chief</b> is responsible for managing all tactical operations occurring at the location of the incident. The Incident Action Plan provides the necessary guidance. The need to expand the <b>Operations Section</b> is generally dictated by the number of tactical resources involved and is influenced by span of control considerations.</p>	<p><b>On-Site Group Supervisor</b> is responsible for coordinating all activities of <b>Control</b>, <b>Containment</b> and <b>Site Safety</b> at the scene of the emergency / incident.</p>	<p>The <b>Staging Area Manager</b> is responsible for managing all activities within a Staging Area.</p>	<p><b>Site Safety</b> is responsible for responder safety and safety advice at all times at the scene of the emergency / incident.</p>	<p><b>Control</b> is responsible for implementing measures designed to bring the incident under control or stop the incident.</p>	<p><b>Containment</b> is responsible for implementing measures designed to reduce the impact of the incident on and prevent the spread of the incident to the surrounding areas.</p>
<ul style="list-style-type: none"> <li>❑ Identify and confirm communication links.</li> <li>❑ Ensure the On-Site Command Post (OSCP) is established.</li> <li>❑ Manage the following positions, as required: <b>On-Site Group Supervisor</b>, <b>Public Safety Group Supervisor</b>.</li> <li>❑ In conjunction with the <b>Incident Commander</b>, the <b>Planning Section Chief</b>, and the <b>Public Safety Group Supervisor</b>, develop and implement an Incident Action Plan (IAP)</li> <li>❑ Ensure responder safety at all times.</li> <li>❑ Oversee control / containment procedures; ensure the hazard is isolated.</li> <li>❑ Determine the current and potential environmental impact of product released, response activities, or waste disposal.</li> <li>❑ Ensure that all environmental laws and regulations are complied with during emergency response operations.</li> <li>❑ Provide technical advice to <b>Incident Commander</b> to determine public protection measures.</li> <li>❑ Assess the requirements for on-site safety supervision, personnel, equipment, and other contract services. Coordinate with <b>Logistics</b> to obtain equipment and resources.</li> <li>❑ Assist the <b>On-Site Group Supervisor</b> in determining whether ignition is appropriate. If at all possible, input is to be obtained from the <b>Incident Commander</b> and the applicable government regulator.</li> <li>❑ Maintain continuous communications with the <b>Incident Commander</b>.</li> </ul>	<ul style="list-style-type: none"> <li>❑ Ensure all personnel are accounted for. Release nonessential personnel from the site</li> <li>❑ Oversee and maintain control of all on-site personnel.</li> <li>❑ Establish On-Site Command Post (OSCP).</li> <li>❑ Obtain incident briefing and environmental impact information.</li> <li>❑ Coordinate activities of <b>Staging Area Manager</b>, <b>Site Safety</b>, <b>Control</b> and <b>Containment</b>.</li> <li>❑ Report air monitoring to <b>Incident Commander</b> (third party and regulatory).</li> <li>❑ Call police, fire and ambulance as needed.</li> <li>❑ Coordinate with ambulance / fire / RCMP / regulatory agencies / spill co-ops.</li> <li>❑ Conduct meetings with on-site personnel to review action plans, communication and safety.</li> <li>❑ Request additional resources needed to implement on-site response actions.</li> <li>❑ Supervise the execution of the on-site response actions.</li> <li>❑ The <b>On-Site Group Supervisor</b> has the authority to ignite the release if ignition criteria are met. If at all possible, the <b>On-Site Group Supervisor</b> must consult with higher authority individuals within the company (ideally the <b>Operations Section Chief</b>, <b>Incident Commander</b>, etc.) and the applicable government regulator before making the decision to ignite a release. Refer to <b>Section 4: Emergency Response Procedures</b>.</li> </ul>	<ul style="list-style-type: none"> <li>❑ Establish a staging area near the incident site and outside of the EPZ. When choosing a site for the staging area ensure the following conditions are met:                             <ul style="list-style-type: none"> <li>❑ Adequate sized site that is stable and level with suitable access roads</li> <li>❑ No entry problems such as narrow approach ways, gates, power lines, buried pipelines, etc.</li> <li>❑ Approval has been received from landowner</li> <li>❑ Reception of communication equipment is adequate</li> </ul> </li> <li>❑ Erect staging area information and directional signs to the staging area, if required.</li> <li>❑ Flag the perimeter of the staging area.</li> <li>❑ Obtain an office trailer and emergency lighting, if required.</li> <li>❑ Coordinate traffic and maintain a log of personnel and services dispatched to, or arriving from the site of the emergency. Communicate this information to the <b>Logistics Section Chief</b>.</li> <li>❑ Respond to <b>Operations Section Chief</b> or <b>Incident Commander</b> requests for resources.</li> <li>❑ Confirm all workers have required training before they are dispatched to the incident.</li> <li>❑ Maintain and provide status to the <b>Planning Section</b> of all resources in Staging Area.</li> <li>❑ Demobilize or move Staging Area as required.</li> </ul>	<ul style="list-style-type: none"> <li>❑ Assess hazards &amp; potential risks e.g. fire/explosion, toxicity, oxygen deficiency, ignition sources, access/egress.</li> <li>❑ Ensure responder safety at all times.</li> <li>❑ Ensure that on-site personnel are taking appropriate safety actions: PPE, SCBA / SABA, Safe Work Procedures, proper grounding / bonding procedures, work in teams, etc.</li> <li>❑ Maintain security of the site to ensure authorized personnel are allowed access and to protect response personnel.</li> <li>❑ Ensure security of any evidence for investigative purposes.</li> <li>❑ Ensure workers that show signs of stress, fatigue, and other symptoms are demobilized and sent for treatment if necessary.</li> <li>❑ Maintain records of all injuries and on-site medical treatments.</li> <li>❑ Conduct responder safety orientations.</li> <li>❑ Monitor activities and conduct a head count on a regular basis.</li> <li>❑ Continually evaluate risks and stop unsafe activities immediately.</li> <li>❑ Recommend alternatives for activities that are considered to be unsafe.</li> </ul>	<ul style="list-style-type: none"> <li>❑ Assist with the development of control procedures.</li> <li>❑ Identify immediate response tactics (i.e. offensive / defensive response tactics). Only when safety is assured, take immediate operational actions to bring the incident under control (i.e. shut down, isolate, de-pressure, etc.).</li> <li>❑ Provide or seek technical / engineering advice around all control-related issues.</li> <li>❑ Inform <b>Operations Section Chief</b> of any interactions with regulatory agencies or environmental personnel.</li> </ul>	<ul style="list-style-type: none"> <li>❑ Assist with the development of containment procedures.</li> <li>❑ Identify immediate response tactics (i.e. offensive / defensive response tactics). Only when safety is assured, take actions to contain the incident so as to prevent the incident from spreading offsite and to reduce the impact on the public, sensitive terrain, watercourses, etc.</li> <li>❑ Provide or seek technical / engineering advice around all containment-related issues.</li> <li>❑ Secure the scene and restrict access to essential and authorized personnel only.</li> <li>❑ Inform <b>Operations Section Chief</b> of any interactions with regulatory agencies or environmental personnel.</li> <li>❑ Coordinate oil spill cooperative activities (booms, dams, etc.).</li> </ul>
<p><b>Important</b></p> <p><b>Prior</b> to beginning any activities, each person in a role must:</p> <ul style="list-style-type: none"> <li>❑ Obtain a completed ICS 201 Incident Briefing and ICS 207 Incident Organization Chart from the <b>Incident Commander</b>.</li> </ul> <p><b>Throughout</b> the duration of the incident, each person in a role must:</p> <ul style="list-style-type: none"> <li>❑ Chronologically document all actions, decisions, contacts and requests on an ICS 214 Activity Log. Copies can be found in <b>Section 6: Forms</b>.</li> </ul> <p><b>After</b> the incident is over, each person in a role must:</p> <ul style="list-style-type: none"> <li>❑ Assist with post-incident activities.</li> </ul> <p style="color: red; font-weight: bold;">All forms referenced can be found in Section 6: Forms</p>					
Located at the Incident Command Post (ICP)	Located at the On-Site Command Post (OSCP)	Located at the Staging Area	Located at the On-Site Command Post (OSCP)	Located at the On-Site Command Post (OSCP)	Located at the On-Site Command Post (OSCP)

Revised November 2021

**Escalate, Downgrade or Stand-Down Levels of Emergency:** As the emergency is brought under control, the decision to downgrade the level and/or stand down the emergency will be based on air monitoring readings in consultation with the **Incident Commander** and the applicable government regulator. All affected persons and the media must be kept informed of the status of an emergency. **Emergency Follow-up:** Once the emergency is over, the area residents, transients, industrial users, involved government agencies, and any individual notified will be informed of the stand-down by the **Information Officer** or **Public Safety Group Supervisor**.

# General Staff Roles – Planning Section

Planning Section Chief	Documentation Unit	Technical Specialists Unit	Situation Unit	Resources Unit	Demobilization Unit																																																									
<p>The <b>Planning Section Chief</b> is responsible for providing planning and status services for the incident. Under the direction of the <b>Planning Section Chief</b>, the Planning Section collects situation and resources status information, evaluates it, and processes the information for use in developing action plans. Dissemination of information can be in the form of the Incident Action Plan, formal briefings, or through map and status board displays.</p>	<p>The <b>Documentation Unit</b> is responsible for the maintenance of accurate, up-to-date incident files. Duplication services will also be provided by the <b>Documentation Unit</b>.</p>	<p>Certain incidents or events may require the use of <b>Technical Specialists</b> who have specialized knowledge and expertise. <b>Technical Specialists</b> may function within the Planning Section, or be assigned wherever their services are required.</p>	<p>The collection, processing, and organization of all incident information. The <b>Situation Unit</b> may prepare future projections of incident growth, maps, and intelligence information.</p>	<p>The <b>Resources Unit</b> is responsible for maintaining the status of all assigned resources at an incident.</p>	<p>The <b>Demobilization Unit</b> is responsible for developing the Incident Demobilization Plan.</p>																																																									
<ul style="list-style-type: none"> <li><input type="checkbox"/> Identify and confirm communication links.</li> <li><input type="checkbox"/> Assign personnel to assume the following positions, as required: <b>Documentation, Technical, Situation, Resources, and Demobilization.</b></li> <li><input type="checkbox"/> Assist with setup of the Incident Command Post.</li> <li><input type="checkbox"/> Review the details of the incident and support the <b>Incident Commander</b> with the development of a preliminary response strategy.</li> <li><input type="checkbox"/> Identify the need for technical specialists.</li> <li><input type="checkbox"/> Collect and analyze information on the current situation, prepare situation displays and situation summaries, and develop maps and projections.</li> <li><input type="checkbox"/> Establish special information collection activities as necessary, e.g., weather, environmental, toxics, etc.</li> <li><input type="checkbox"/> Provide technical support to the <b>Incident Commander</b> and work with <b>Incident Commander</b> to develop the Incident Action Plan (IAP).</li> <li><input type="checkbox"/> Review any changes to the Incident Action Plan (IAP) to ensure consistency.</li> <li><input type="checkbox"/> Assemble information on alternative strategies.</li> <li><input type="checkbox"/> Coordinate with <b>Logistics</b> to determine current available resources and resource availability for future plans of action.</li> <li><input type="checkbox"/> Establish reporting schedules.</li> <li><input type="checkbox"/> Conduct long-range and / or contingency planning.</li> <li><input type="checkbox"/> Develop plans for demobilization.</li> <li><input type="checkbox"/> Maintain continuous communications with the <b>Incident Commander</b>.</li> </ul> <div style="text-align: right; margin-top: 10px;"> <table border="1" style="display: inline-table; border-collapse: collapse;"> <tr> <td style="padding: 2px;">Form</td> <td style="padding: 2px;">Form</td> <td style="padding: 2px;">Form</td> <td style="padding: 2px;">Form</td> <td style="padding: 2px;">Form</td> </tr> <tr> <td style="padding: 2px;">ICS</td> <td style="padding: 2px;">ICS</td> <td style="padding: 2px;">ICS</td> <td style="padding: 2px;">ICS</td> <td style="padding: 2px;">ICS</td> </tr> <tr> <td style="padding: 2px;">202</td> <td style="padding: 2px;">214</td> <td style="padding: 2px;">215</td> <td style="padding: 2px;">215a</td> <td style="padding: 2px;">230</td> </tr> </table> </div>	Form	Form	Form	Form	Form	ICS	ICS	ICS	ICS	ICS	202	214	215	215a	230	<ul style="list-style-type: none"> <li><input type="checkbox"/> Document the Incident Action Plan (IAP) strategies using the ICS 201 Incident Briefing Form provided in <b>Section 1: Initial Response</b> or <b>Section 6: Forms</b> and disseminate them to all key responders. <ul style="list-style-type: none"> <li><input type="checkbox"/> Be prepared to document the <b>Incident Commander's</b> status update meetings using whiteboards, PC or Action Logs.</li> </ul> </li> <li><input type="checkbox"/> Ensure consistent documentation.</li> <li><input type="checkbox"/> Ensure timely dissemination of all documentation.</li> <li><input type="checkbox"/> Participate in planning meetings, capturing key information, decisions made, commitments and status.</li> <li><input type="checkbox"/> Collect documentation from response team members and maintain a consistent system for organizing the data. <ul style="list-style-type: none"> <li><input type="checkbox"/> Records must be held for a minimum of 5 years as it may be requested by the regulatory agency at any point during that time.</li> </ul> </li> <li><input type="checkbox"/> Establish duplication services.</li> <li><input type="checkbox"/> Incident files will be stored for legal, analytical, and historical purposes.</li> <li><input type="checkbox"/> Post and maintain all Emergency Status Boards and other laminated charts in the Incident Command Post.</li> </ul> <div style="text-align: right; margin-top: 10px;"> <table border="1" style="display: inline-table; border-collapse: collapse;"> <tr> <td style="padding: 2px;">Form</td> <td style="padding: 2px;">Form</td> <td style="padding: 2px;">Form</td> <td style="padding: 2px;">Form</td> </tr> <tr> <td style="padding: 2px;">ICS</td> <td style="padding: 2px;">ICS</td> <td style="padding: 2px;">ICS</td> <td style="padding: 2px;">ICS</td> </tr> <tr> <td style="padding: 2px;">201</td> <td style="padding: 2px;">214</td> <td style="padding: 2px;">231</td> <td style="padding: 2px;">233</td> </tr> </table> </div>	Form	Form	Form	Form	ICS	ICS	ICS	ICS	201	214	231	233	<ul style="list-style-type: none"> <li><input type="checkbox"/> Determine what technical support is available now and in the future.</li> <li><input type="checkbox"/> Work with <b>Logistics</b> to determine the key locations for the required technical support and appropriate time to acquire.</li> <li><input type="checkbox"/> Gather data (weather, etc.) and forecast changes considering incident potential and develop new or modified response strategies.</li> <li><input type="checkbox"/> As required, obtain plume dispersion modelling.</li> </ul>	<ul style="list-style-type: none"> <li><input type="checkbox"/> Collect and evaluate information to establish an accurate picture of the situation and creates a detailed summary. Use this information to create maps and projections.</li> <li><input type="checkbox"/> Prepare, post, or disseminate resources and situation status information as required, including special requests.</li> <li><input type="checkbox"/> Provide photographic services and maps if required.</li> </ul> <div style="text-align: right; margin-top: 10px;"> <table border="1" style="display: inline-table; border-collapse: collapse;"> <tr> <td style="padding: 2px;">Form</td> <td style="padding: 2px;">Form</td> <td style="padding: 2px;">Form</td> </tr> <tr> <td style="padding: 2px;">ICS</td> <td style="padding: 2px;">ICS</td> <td style="padding: 2px;">ICS</td> </tr> <tr> <td style="padding: 2px;">201</td> <td style="padding: 2px;">209</td> <td style="padding: 2px;">214</td> </tr> </table> </div>	Form	Form	Form	ICS	ICS	ICS	201	209	214	<ul style="list-style-type: none"> <li><input type="checkbox"/> Monitor the status and location of all incident resources / personnel responding to the incident.</li> <li><input type="checkbox"/> Oversee the check-in of all resources.</li> <li><input type="checkbox"/> Maintenance of a master list of all resources, e.g., key supervisory personnel, primary and support resources, etc.</li> <li><input type="checkbox"/> May assist in preparing the written Incident Action Plan.</li> <li><input type="checkbox"/> Maintain and post the current status and location of all resources.</li> </ul> <div style="text-align: right; margin-top: 10px;"> <table border="1" style="display: inline-table; border-collapse: collapse;"> <tr> <td style="padding: 2px;">Form</td> <td style="padding: 2px;">Form</td> <td style="padding: 2px;">Form</td> <td style="padding: 2px;">Form</td> <td style="padding: 2px;">Form</td> </tr> <tr> <td style="padding: 2px;">ICS</td> <td style="padding: 2px;">ICS</td> <td style="padding: 2px;">ICS</td> <td style="padding: 2px;">ICS</td> <td style="padding: 2px;">ICS</td> </tr> <tr> <td style="padding: 2px;">203</td> <td style="padding: 2px;">204</td> <td style="padding: 2px;">207</td> <td style="padding: 2px;">211</td> <td style="padding: 2px;">214</td> </tr> </table> </div>	Form	Form	Form	Form	Form	ICS	ICS	ICS	ICS	ICS	203	204	207	211	214	<ul style="list-style-type: none"> <li><input type="checkbox"/> Prepare plan for the demobilization of all personnel and equipment upon resolution of the incident.</li> <li><input type="checkbox"/> Ensure resources in available status are still required. Identify surplus resources and probably release time.</li> <li><input type="checkbox"/> Debrief non-required resources and dismiss resources being demobilized.</li> <li><input type="checkbox"/> Coordinate demobilization with agency representatives.</li> <li><input type="checkbox"/> Develop incident check-out function for all units.</li> <li><input type="checkbox"/> Ensure the demobilization process is organized, safe and cost effective.</li> </ul> <div style="text-align: right; margin-top: 10px;"> <table border="1" style="display: inline-table; border-collapse: collapse;"> <tr> <td style="padding: 2px;">Form</td> <td style="padding: 2px;">Form</td> </tr> <tr> <td style="padding: 2px;">ICS</td> <td style="padding: 2px;">ICS</td> </tr> <tr> <td style="padding: 2px;">214</td> <td style="padding: 2px;">221</td> </tr> </table> </div>	Form	Form	ICS	ICS	214	221
Form	Form	Form	Form	Form																																																										
ICS	ICS	ICS	ICS	ICS																																																										
202	214	215	215a	230																																																										
Form	Form	Form	Form																																																											
ICS	ICS	ICS	ICS																																																											
201	214	231	233																																																											
Form	Form	Form																																																												
ICS	ICS	ICS																																																												
201	209	214																																																												
Form	Form	Form	Form	Form																																																										
ICS	ICS	ICS	ICS	ICS																																																										
203	204	207	211	214																																																										
Form	Form																																																													
ICS	ICS																																																													
214	221																																																													
<p style="text-align: center; color: red; margin: 0;"><b>Important</b></p> <p><b>Prior</b> to beginning any activities, each person in a role must:</p> <ul style="list-style-type: none"> <li><input type="checkbox"/> Obtain a completed ICS 201 Incident Briefing and ICS 207 Incident Organization Chart from the <b>Incident Commander</b>.</li> </ul> <p><b>Throughout</b> the duration of the incident, each person in a role must:</p> <ul style="list-style-type: none"> <li><input type="checkbox"/> Chronologically document all actions, decisions, contacts and requests on an ICS 214 Activity Log. Copies can be found in <b>Section 6: Forms</b>.</li> </ul> <p><b>After</b> the incident is over, each person in a role must:</p> <ul style="list-style-type: none"> <li><input type="checkbox"/> Assist with post-incident activities.</li> </ul> <p style="text-align: center; color: red; margin-top: 5px;"><b>All forms referenced can be found in Section 6: Forms</b></p>																																																														

**All team members are located at the Incident Command Post (ICP), unless otherwise noted.**

Revised October 2018

Escalate, Downgrade or Stand-Down Levels of Emergency: As the emergency is brought under control, the decision to downgrade the level and/or stand down the emergency will be based on air monitoring readings in consultation with the **Incident Commander** and the applicable government regulator. All affected persons and the media must be kept informed of the status of an emergency. **Emergency Follow-up:** Once the emergency is over, the area residents, transients, industrial users, involved government agencies, and any individual notified will be informed of the stand-down by the **Information Officer** or **Public Safety Group Supervisor**.

# General Staff Roles – Logistics Section

Logistics Section Chief	Communications Unit	Medical unit	Food Unit	Supply Unit	Facilities Unit	Ground Support Unit
<p>All incident support needs are provided by the Logistics Section. The section is responsible for providing: facilities, transportation, communications, supplies, equipment maintenance and fuelling, food services, medical services, and ordering resources. Six units may be established within the Logistics Section and the <b>Logistics Section Chief</b> will determine the need to activate or deactivate a unit. If a unit is not activated, responsibility for that unit's duties will remain with the <b>Logistics Section Chief</b>.</p>	<p>The <b>Communications Unit</b> is responsible for developing plans for the use of incident communications equipment and facilities; installing and testing of communications equipment; supervision of the Incident Communications Centre, if established; and the distribution and maintenance of communications equipment.</p>	<p>The <b>Medical Unit</b> is responsible for all medical services for incident assigned personnel. The unit will develop procedures for managing major medical emergencies; and provide medical aid.</p> <p><i>Note: Medical assistance to the public or victims of the emergency is an operational function.</i></p>	<p>Responsible for supplying the food needs for the entire incident, including all remote locations, (e.g., Camps, Staging Areas), as well as providing food for personnel unable to leave tactical field assignments. The <b>Food Unit</b> interacts with the <b>Facilities Unit</b> for location of fixed-feeding site; the <b>Supply Unit</b> for food ordering; and the <b>Ground Support Unit</b> for transporting food.</p>	<p>The <b>Supply Unit</b> is responsible for ordering, receiving, processing, and storing all incident-related resources.</p>	<p>The <b>Facilities Unit</b> is responsible for set-up, maintenance, and demobilization of all incident support facilities except staging areas. The <b>Facilities Unit</b> will also provide security services to the incident as needed.</p>	<p>The Ground Support Unit is primarily responsible for the maintenance, services, and fuelling of all mobile equipment and vehicles, with the exception of aviation resources. The unit also has responsibility for the ground transportation of personnel, supplies, and equipment.</p>
<ul style="list-style-type: none"> <li><input type="checkbox"/> Identify and confirm communication links.</li> <li><input type="checkbox"/> Assign personnel as required.</li> <li><input type="checkbox"/> List and obtain all immediate resources requested by the <b>Incident Commander</b> or <b>Operations Section Chief</b>.</li> <li><input type="checkbox"/> Identify anticipated and known incident service and support requirements.</li> <li><input type="checkbox"/> Maintain continuous communications with the <b>Incident Commander</b>.</li> <li><input type="checkbox"/> Develop plans to move required resources to site.</li> <li><input type="checkbox"/> Confirm spending authorities with the Finance / Admin Section.</li> <li><input type="checkbox"/> Mobilize resources.</li> <li><input type="checkbox"/> Move required resources to site.</li> <li><input type="checkbox"/> Coordinate spending with the <b>Finance / Admin Section Chief</b>.</li> </ul>	<ul style="list-style-type: none"> <li><input type="checkbox"/> Establish the communications plan for the use of incident communications equipment and facilities.</li> <li><input type="checkbox"/> Install, test, distribute, and maintain all communications equipment.</li> <li><input type="checkbox"/> Advise on communications capabilities and limitations.</li> <li><input type="checkbox"/> Establish telephone, communication links, and public address systems.</li> <li><input type="checkbox"/> Establish clear and widespread communication throughout the incident.</li> </ul>	<ul style="list-style-type: none"> <li><input type="checkbox"/> Arrange and provide response personnel with first aid and minor medical services.</li> <li><input type="checkbox"/> Develop Incident Medical Plan.</li> <li><input type="checkbox"/> Develop procedures for handling serious injuries of responder personnel.</li> <li><input type="checkbox"/> Provide medical aid to personnel.</li> <li><input type="checkbox"/> Assist the Finance / Administration Section with processing injury-related claims.</li> </ul> <p><i>Note: Provision of medical assistance to the public or victims of the emergency is an operational function and would be done by the Operations Section Medical Unit. If there is a requirement for victims of an incident the local public ambulance service is most often utilized.</i></p>	<ul style="list-style-type: none"> <li><input type="checkbox"/> Responsible for supplying the food needs for the entire incident, including all remote locations (e.g., Camps, Staging Areas), as well as providing food for personnel unable to leave tactical field assignments.</li> <li><input type="checkbox"/> Works with the Planning Section - <b>Resources Unit</b> to anticipate the numbers of personnel to be fed and develop plans for supplying food to all incident areas.</li> <li><input type="checkbox"/> Interacts with the <b>Facilities Unit</b> for location of fixed-feeding site; the <b>Supply Unit</b> for food ordering; and the <b>Ground and Air Support Units</b> for transporting food.</li> <li><input type="checkbox"/> Obtain necessary equipment and supplies and establish cooking facilities.</li> <li><input type="checkbox"/> Order sufficient food and potable water from the <b>Supply Unit</b>.</li> <li><input type="checkbox"/> Maintain inventory of food and water.</li> <li><input type="checkbox"/> Maintain food services areas, ensuring that all appropriate health and safety measures and being followed.</li> <li><input type="checkbox"/> Supervise caterers, cooks, and other <b>Food Unit</b> personnel as appropriate.</li> </ul>	<ul style="list-style-type: none"> <li><input type="checkbox"/> Order, receive, distribute and track all incident equipment and supplies.</li> <li><input type="checkbox"/> Ordered all off-incident resources including: tactical and support resources (including personnel), all expendable and non-expendable support supplies.</li> <li><input type="checkbox"/> Management of tool operations, including the storage, disbursement, and service of all tools and portable non-expendable equipment.</li> </ul>	<ul style="list-style-type: none"> <li><input type="checkbox"/> Set-up, maintain, and demobilize incident support facilities with the exception of staging areas.</li> <li><input type="checkbox"/> Facilities may include: Incident Command Post, Incident Base, Camps, and other facilities within the incident area to be used for feeding, sleeping and sanitation services.</li> <li><input type="checkbox"/> Prepare layout of facilities; inform appropriate unit leaders.</li> <li><input type="checkbox"/> Will provide security services to the incident as needed.</li> <li><input type="checkbox"/> Contact local law enforcement agencies as required.</li> <li><input type="checkbox"/> Investigate and document all complaints and suspicious occurrences.</li> <li><input type="checkbox"/> Ensure strict compliance with applicable safety regulations.</li> <li><input type="checkbox"/> Provide facility maintenance services, e.g., sanitation, lighting, etc.</li> <li><input type="checkbox"/> Demobilize base and camp facilities.</li> </ul>	<ul style="list-style-type: none"> <li><input type="checkbox"/> Responsible for the maintenance, service and fuelling of all mobile equipment and vehicles, with the exception of aviation resources.</li> <li><input type="checkbox"/> Coordinates the transportation of all personnel, supplies, and equipment.</li> <li><input type="checkbox"/> Update the <b>Resources Unit</b> with the status (location and capability) of transportation vehicles.</li> <li><input type="checkbox"/> Develop the Incident Traffic Plan as required.</li> </ul>
<p style="text-align: center;"><b>Important</b></p> <p><b>Prior</b> to beginning any activities, each person in a role must:</p> <ul style="list-style-type: none"> <li><input type="checkbox"/> Obtain a completed ICS 201 Incident Briefing and ICS 207 Incident Organization Chart from the <b>Incident Commander</b>.</li> </ul> <p><b>Throughout</b> the duration of the incident, each person in a role must:</p> <ul style="list-style-type: none"> <li><input type="checkbox"/> Chronologically document all actions, decisions, contacts and requests on an ICS 214 Activity Log. Copies can be found in <b>Section 6: Forms</b>.</li> </ul> <p><b>After</b> the incident is over, each person in a role must:</p> <ul style="list-style-type: none"> <li><input type="checkbox"/> Assist with post-incident activities.</li> </ul> <p style="text-align: center; color: red;"><b>All forms referenced can be found in Section 6: Forms</b></p>						

**All team members are located at the Incident Command Post (ICP), unless otherwise noted.**

Revised October 2018

**Escalate, Downgrade or Stand-Down Levels of Emergency:** As the emergency is brought under control, the decision to downgrade the level and/or stand down the emergency will be based on air monitoring readings in consultation with the **Incident Commander** and the applicable government regulator. All affected persons and the media must be kept informed of the status of an emergency. **Emergency Follow-up:** Once the emergency is over, the area residents, transients, industrial users, involved government agencies, and any individual notified will be informed of the stand-down by the **Information Officer** or **Public Safety Group Supervisor**.

# General Staff Roles – Finance / Admin Section

Finance / Admin Section Chief	Time Unit	Procurement Unit	Compensation & Claims Unit	Cost Unit
<p>The <b>Finance / Administration Section Chief</b> is responsible for managing all financial aspects of an incident. The <b>Finance / Administration Section Chief</b> will determine the need to activate or deactivate a unit.</p>	<p>The <b>Time Unit</b> is responsible for ensuring the accurate recording of daily personnel time, compliance with specific agency time recording policies and managing commissary operations if established at the incident.</p>	<p>All financial matters pertaining to vendor contracts, leases and fiscal agreements are managed by the <b>Procurement Unit</b>. The unit is also responsible for maintaining equipment time records. The <b>Procurement Unit</b> establishes local sources for equipment and supplies; manages all equipment rental agreements; and processes all rental and supply fiscal document billing invoices.</p>	<p>This unit oversees the completion of all forms required by workers' compensation and local agencies. A file of injuries and illnesses associated with the incident will also be maintained and all witness statement will be obtained in writing. Close coordination with the medical Unit is essential. The <b>Compensation &amp; Claims Unit</b> is also responsible for investigating all claims involving property associated with or involved in the incident.</p>	<p>The <b>Cost Unit</b> provides all incident cost analysis. It ensures the proper identification of all equipment and personnel requiring payment; records all cost data; analyzes and prepares estimates of incident costs; and maintains accurate records of incident costs.</p>
<ul style="list-style-type: none"> <li><input type="checkbox"/> Identify and confirm communication links.</li> <li><input type="checkbox"/> Assign personnel to assume the following positions, as required: <b>Time Unit, Procurement Unit, Compensation &amp; Claims Unit, and Cost Unit.</b></li> <li><input type="checkbox"/> Review legal issues with the <b>Incident Commander.</b></li> <li><input type="checkbox"/> Maintain continuous communications with the <b>Incident Commander.</b></li> <li><input type="checkbox"/> Brief agency administrative personnel on all incident-related financial issues needing attention or follow-up.</li> <li><input type="checkbox"/> Manage all financial aspects of an incident.</li> </ul>	<ul style="list-style-type: none"> <li><input type="checkbox"/> Record daily personnel time, ensure compliance with specific agency time recording policies, and manage commissary operations if established at the incident.</li> <li><input type="checkbox"/> Submit cost estimate data forms to <b>Cost Unit</b> as required.</li> <li><input type="checkbox"/> Ensure that all records are current and complete prior to demobilization.</li> </ul>	<ul style="list-style-type: none"> <li><input type="checkbox"/> Manage finances relating to vendor contracts, leases and fiscal agreements.</li> <li><input type="checkbox"/> Maintain equipment time records.</li> <li><input type="checkbox"/> Establish local sources for equipment and supplies. Coordinate with local jurisdiction on plans and supply sources.</li> <li><input type="checkbox"/> Manage all equipment rental agreements. Establish contracts and agreement with supply vendors.</li> <li><input type="checkbox"/> Processes all rental and supply fiscal document billing invoices.</li> <li><input type="checkbox"/> Prepare and authorize contracts and land use agreements, as needed.</li> </ul>	<ul style="list-style-type: none"> <li><input type="checkbox"/> Handle all matters relating to compensation for injury or property damage due to the incident.</li> <li><input type="checkbox"/> Oversees the completion of all forms required by workers' compensation and local agencies.</li> <li><input type="checkbox"/> Maintain a file with all the injuries and illnesses associated with the incident.</li> <li><input type="checkbox"/> Obtain witness statements in writing.</li> <li><input type="checkbox"/> Investigate all claims involving property associated with or involved in the incident.</li> <li><input type="checkbox"/> Ensure the completion of a Resident Compensation Log for any out-of-pocket expenses incurred by evacuees. <span style="border: 1px solid black; padding: 2px; font-size: small;">Form B2</span></li> <li><input type="checkbox"/> All claims must be submitted to the Finance and Legal departments for processing and disbursement of funds.                             <ul style="list-style-type: none"> <li><input type="checkbox"/> If applicable, Finance and Legal will deal with insurers as well as any other extraneous circumstances (affected parties want more, etc.).</li> </ul> </li> </ul>	<ul style="list-style-type: none"> <li><input type="checkbox"/> Collect and evaluate cost data to establish an accurate picture of the incident costs.</li> <li><input type="checkbox"/> Create cost summaries, cost estimates, and cost saving recommendations.</li> <li><input type="checkbox"/> Prepare resources-use cost estimates for the Planning Section.</li> <li><input type="checkbox"/> Identify all equipment and personnel requiring payment.</li> </ul>

Important

**Prior** to beginning any activities, each person in a role must:

- Obtain a completed ICS 201 Incident Briefing and ICS 207 Incident Organization Chart from the **Incident Commander.**

**Throughout** the duration of the incident, each person in a role must:

- Chronologically document all actions, decisions, contacts and requests on an ICS 214 Activity Log. Copies can be found in **Section 6: Forms.**

**After** the incident is over, each person in a role must:

- Assist with post-incident activities.

All forms referenced can be found in Section 6: Forms

**All team members are located at the Incident Command Post (ICP), unless otherwise noted.**

Revised October 2018

**Escalate, Downgrade or Stand-Down Levels of Emergency:** As the emergency is brought under control, the decision to downgrade the level and/or stand down the emergency will be based on air monitoring readings in consultation with the **Incident Commander** and the applicable government regulator. All affected persons and the media must be kept informed of the status of an emergency. **Emergency Follow-up:** Once the emergency is over, the area residents, transients, industrial users, involved government agencies, and any individual notified will be informed of the stand-down by the **Information Officer** or **Public Safety Group Supervisor.**

# Operations Section - Public Safety Roles

Public Safety Group Supervisor	Air Monitors	Reception Centre Rep	Roadblocks	Rovers	Telephoners
<p><b>The Public Safety Group Supervisor is responsible for the management, planning, consideration, and implementation of external public protection activities for the duration of the incident.</b></p> <ul style="list-style-type: none"> <li><input type="checkbox"/> Confirm communication links with the <b>Incident Commander</b> and <b>Operations Section Chief</b>.</li> <li><input type="checkbox"/> In conjunction with the <b>Incident Commander</b>: determine the size of the EPZ; identify the residents, businesses, industrial operators, and / or transients in the area; and determine the initial public protection measures to be taken. Consider the impact of major highways, navigable water courses, cleared pipeline rights of way &amp; railways in the hazard area. Refer to <b>Section 4: Emergency Response Procedures</b> for guidelines on evacuation / shelter, ignition, roadblocks, rovers, public concerns, etc. Additional information for <b>Air Monitors, Reception Centre Representative, Roadblocks, Rovers, and Telephoners</b> can be found in <b>Section 2: Roles &amp; Responsibilities</b>.</li> <li><input type="checkbox"/> In conjunction with the <b>Incident Commander, Planning Section Chief, and Operations Section Chief</b>, develop and implement an Incident Action Plan (IAP).</li> <li><input type="checkbox"/> Review resident lists, area user lists, reception centres, and telephone numbers within the ERP.</li> <li><input type="checkbox"/> If required, establish a Regional Emergency Operations Centre (REOC).</li> <li><input type="checkbox"/> Assign personnel to assume the following positions as required: <b>Air Monitors, Reception Centre Representative, Roadblocks, Rovers, and Telephoners</b>.                             <ul style="list-style-type: none"> <li><input type="checkbox"/> The <b>Telephoners</b> must have sufficient personnel to accommodate the following ratios when contacting residents: 1 Telephoner to every 7 residences; and 1 Supervisor for every 10 Telephoners.</li> </ul> </li> <li><input type="checkbox"/> Dispatch <b>Air Monitors</b> at a Level 1 emergency (hand-held and mobile).                             <ul style="list-style-type: none"> <li><input type="checkbox"/> Dispatch trained personnel with the appropriate hand-held gas monitors to record concentrations of LEL and H<sub>2</sub>S at the nearest un-evacuated residences downwind of the incident site.</li> <li><input type="checkbox"/> Mobilize third party mobile air monitoring units which can measure in parts per billion (ppb)</li> <li><input type="checkbox"/> Maintain communication with the applicable government regulator and environment agency regarding air monitoring needs and activities.</li> <li><input type="checkbox"/> Consult with the <b>Operations Section Chief</b> to determine the need for evacuation / sheltering. This is based on air monitoring readings at the nearest downwind residence.</li> </ul> </li> <li><input type="checkbox"/> Prioritize public closest to, downwind, those that have requested early notification, and those with special needs to establish the order of evacuation. Coordinate evacuation or shelter of residents, area users, and transients (via <b>Telephoners and Rovers</b>).                             <ul style="list-style-type: none"> <li><input type="checkbox"/> Determine who needs to be notified and what script will be used: Early Notification / Voluntary Evacuation Message, Shelter-in-Place Phone Message, Evacuation Phone Message. <span style="float: right;">Form B6 Form B7 Form B8</span></li> <li><input type="checkbox"/> At a Level 1 Emergency it is required to notify any special needs residents and give them the option to evacuate.</li> <li><input type="checkbox"/> If residences are evacuated, a reception centre must be established.</li> <li><input type="checkbox"/> Determine and notify landowner / occupant(s) as soon as possible.</li> <li><input type="checkbox"/> Ensure the schools / school buses are contacted to make arrangements for school age children (if applicable).</li> <li><input type="checkbox"/> If a large number of people need to be evacuated (large industrial operations and/or public facilities) refer to the <b>Area Specific Information</b> section (white tabs) for contacts to obtain charter buses or changes to the normal notification procedures.</li> <li><input type="checkbox"/> Send <b>Rovers</b> (if required) to identify human activity in the area which is not already identified within the ERP (drilling, pipeline construction, logging, hunting, farming, camping, fishing, etc.).</li> <li><input type="checkbox"/> Prepare Evacuation Notices and provide copies to <b>Rovers</b>.</li> <li><input type="checkbox"/> <b>Rovers</b> can be used to assist with notifications, assist with evacuating special needs residents, assist with air monitoring, etc.</li> <li><input type="checkbox"/> Continually assess the need for additional evacuation, shelter or ignition based on air monitoring readings.</li> </ul> </li> <li><input type="checkbox"/> Determine the need for helicopters to identify human activity in the area.</li> <li><input type="checkbox"/> Determine the need for and location of <b>Roadblocks</b> to isolate and secure the area.                             <ul style="list-style-type: none"> <li><input type="checkbox"/> Dispatch trained personnel with the appropriate equipment to establish roadblocks on the roads entering/exiting the hazard area. <span style="float: right;">Form B5</span></li> <li><input type="checkbox"/> Contact the RCMP &amp; Ministry of Transportation for permission to close 1, 2, or 3 digit provincial or secondary highways.</li> </ul> </li> <li><input type="checkbox"/> Assess and expand the incident response to include those outside of the EPZ if required by air monitoring readings. Coordinate public protection measures outside the EPZ with the local authority.</li> <li><input type="checkbox"/> Ensure security of evacuated homes, at roadblocks, and at the reception centre.</li> <li><input type="checkbox"/> Regularly update the <b>Incident Commander</b>.</li> <li><input type="checkbox"/> Confirm communication links with: <b>Air Monitors, Reception Centre, Roadblocks, Rovers, and Telephoners</b>. Personnel should check in at scheduled intervals.</li> <li><input type="checkbox"/> Review and confirm evacuation of residents, area industrial users, transients, etc. from the area.</li> <li><input type="checkbox"/> Request that a Notice to Airmen (NOTAM) is issued to restrict the airspace above the EPZ.</li> </ul>	<p><b>Air Monitoring</b> personnel are responsible for acquiring and providing air quality readings to the <b>Public Safety Group Supervisor</b>.</p> <ul style="list-style-type: none"> <li><input type="checkbox"/> Use the buddy system and equip each responder with reliable monitors and respiratory protective equipment. The monitors must be capable of displaying readings for 1 ppm H<sub>2</sub>S and LEL conditions.</li> <li><input type="checkbox"/> Establish and maintain communication with the OSCP using cellular phones or 2-way radios.</li> <li><input type="checkbox"/> Provide air monitoring readings to assist with decision making (evacuation / shelter / ignition).</li> <li><input type="checkbox"/> Obtain and check equipment and information (maps, forms, communications, reports, monitors, safety, and breathing equipment).</li> <li><input type="checkbox"/> Confirm communication links.</li> <li><input type="checkbox"/> Monitor closest downwind public location or residence.</li> <li><input type="checkbox"/> Monitor environment for adverse effects.                             <ul style="list-style-type: none"> <li><input type="checkbox"/> Record all readings on the Air Monitoring Log. <span style="float: right;">Form A5</span></li> </ul> </li> <li><input type="checkbox"/> Report all readings at established intervals to the <b>Public Safety Group Supervisor</b>.</li> <li><input type="checkbox"/> For your own safety, ensure <b>Public Safety Group Supervisor</b> is notified immediately if readings are approaching 10% LEL and / or 10 ppm H<sub>2</sub>S.                             <ul style="list-style-type: none"> <li><input type="checkbox"/> Prepare Mobile Monitoring Plan. <span style="float: right;">Form B2</span></li> </ul> </li> <li><input type="checkbox"/> If walking the pipeline right-of-way, walk separately with the wind, staying within visual contact and calling distance. As the lead responder monitors for H<sub>2</sub>S, the backup responder will maintain communication and be prepared to rescue; and</li> <li><input type="checkbox"/> SO<sub>2</sub> monitoring equipment will be called out as required.</li> </ul> <div style="border: 2px solid red; padding: 5px; margin-top: 10px;"> <p style="text-align: center; color: red;"><b>Important</b></p> <p><b>Prior to beginning any activities, each person in a role must:</b></p> <ul style="list-style-type: none"> <li><input type="checkbox"/> Obtain a completed ICS 201 Incident Briefing and ICS 207 Incident Organization Chart from the <b>Incident Commander</b>.</li> </ul> <p><b>Throughout the duration of the incident, each person in a role must:</b></p> <ul style="list-style-type: none"> <li><input type="checkbox"/> Chronologically document all actions, decisions, contacts and requests on an ICS 214 Activity Log. Copies can be found in <b>Section 6: Forms</b>.</li> </ul> <p><b>After the incident is over, each person in a role must:</b></p> <ul style="list-style-type: none"> <li><input type="checkbox"/> Assist with post-incident activities.</li> </ul> <p style="text-align: center; color: red;"><b>All forms referenced can be found in Section 6: Forms</b></p> </div>	<p><b>Reception Centre Reps</b> are responsible for establishing reception centres, managing evacuee accommodation, communication, and documentation for compensation purposes.</p> <ul style="list-style-type: none"> <li><input type="checkbox"/> Confirm reception centre is available for use.</li> <li><input type="checkbox"/> Establish reception centre. Refer to <b>Section 2: Roles &amp; Responsibilities</b>. <span style="float: right;">Form B1</span></li> <li><input type="checkbox"/> Confirm communication links.</li> <li><input type="checkbox"/> Receive evacuees and maintain a Reception Centre Registration Log.</li> <li><input type="checkbox"/> Arrange for food and accommodations for the evacuees.                             <ul style="list-style-type: none"> <li><input type="checkbox"/> Provide evacuees with a place to request counselling services, if required.</li> </ul> </li> <li><input type="checkbox"/> Record and follow up on all evacuees who choose to make their own accommodation arrangements.</li> <li><input type="checkbox"/> Arrange for temporary care of livestock (if possible) and the security of evacuated property.</li> <li><input type="checkbox"/> Establish and oversee compensation administration activities at the reception centre.                             <ul style="list-style-type: none"> <li><input type="checkbox"/> Reimburse evacuees for their immediate out-of-pocket expenses and log details on a Resident Compensation Log. <span style="float: right;">Form B2</span></li> </ul> </li> <li><input type="checkbox"/> Where possible, provide evacuees with information regarding their property, livestock, and the incident.</li> <li><input type="checkbox"/> Forward all media and incident inquiries to the <b>Information Officer</b>. <span style="float: right;">Form B4</span></li> <li><input type="checkbox"/> Report all names of evacuees who have registered at the reception centre to the <b>Public Safety Group Supervisor</b>.</li> <li><input type="checkbox"/> Address resident concerns and forward them to the <b>Public Safety Group Supervisor</b>.</li> </ul>	<p><b>Roadblock</b> personnel are responsible for restricting unauthorized entry into the hazard areas during an incident that could potentially jeopardize public safety.</p> <ul style="list-style-type: none"> <li><input type="checkbox"/> In conjunction with the <b>Public Safety Group Supervisor</b> determine the need for and location of roadblocks.                             <ul style="list-style-type: none"> <li><input type="checkbox"/> Pickup and check roadblock kits.</li> <li><input type="checkbox"/> Proceed to roadblock locations.</li> <li><input type="checkbox"/> Determine driving directions to assigned roadblock location that does not have you pass through the hazard area.</li> </ul> </li> <li><input type="checkbox"/> Confirm communication links.</li> <li><input type="checkbox"/> Establish roadblocks to secure the EPZ.</li> <li><input type="checkbox"/> Follow the scripts and procedures in the ERP. Refer to either <b>Section 2: Roles &amp; Responsibilities</b> or <b>Section 6: Forms</b>.                             <ul style="list-style-type: none"> <li><input type="checkbox"/> If media personnel show up at your roadblock, forward all requests to your direct supervisor who'll direct them to the <b>Information Officer</b>. <span style="float: right;">Form A5</span></li> </ul> </li> <li><input type="checkbox"/> Monitor area for H<sub>2</sub>S and / or LEL with personal monitors and document readings on the Air Monitoring Log. <span style="float: right;">Form A5</span></li> <li><input type="checkbox"/> Report all H<sub>2</sub>S and / or LEL reading changes / increases to the <b>Public Safety Group Supervisor</b>.</li> <li><input type="checkbox"/> For your own safety, ensure the <b>Public Safety Group Supervisor</b> is notified immediately if readings are approaching 10% LEL and / or 10 ppm H<sub>2</sub>S.                             <ul style="list-style-type: none"> <li><input type="checkbox"/> Record all incoming and outgoing traffic, personnel, and equipment on the Roadblock Log. <span style="float: right;">Form B4</span></li> </ul> </li> <li><input type="checkbox"/> Forward information given to you by people passing through your location to the <b>Public Safety Group Supervisor</b>.</li> <li><input type="checkbox"/> Report any person that insists on going through the roadblock into the hazard area as well as any suspicious activity to the <b>Public Safety Group Supervisor</b>.</li> <li><input type="checkbox"/> Maintain communication with the <b>Public Safety Group Supervisor</b>.</li> <li><input type="checkbox"/> Maintain roadblock locations. Do not leave until requested to do so by the <b>Public Safety Group Supervisor</b> or until relieved by other <b>Roadblock</b> personnel.</li> </ul> <p style="font-size: small; color: red;"><i>Note: See Section 2: Roles &amp; Responsibilities for a media script for Roadblock and Rover personnel.</i></p>	<p><b>Rovers</b> travel to assigned locations to locate the public and personally provide public safety instructions and assistance as required. This may be completed via truck, ATV, boat, helicopter, etc.</p> <ul style="list-style-type: none"> <li><input type="checkbox"/> Confirm resident contact lists are available.</li> <li><input type="checkbox"/> Confirm communication links.</li> <li><input type="checkbox"/> Know safe routes in and out of the EPZ.</li> <li><input type="checkbox"/> Search for residents and transients in the Emergency Response and Planning Zones.</li> <li><input type="checkbox"/> Check all buildings including barns, shops, sheds, etc.</li> <li><input type="checkbox"/> Assist, as required, with the notification, evacuation or sheltering of persons within the EPZ. Record all contact with residents using the Resident Contact Log. <span style="float: right;">Form B3</span></li> <li><input type="checkbox"/> Post Evacuation Notices for residents that are not at their residence. <span style="float: right;">Form B5</span></li> <li><input type="checkbox"/> Follow the scripts and procedures in the ERP. Refer to <b>Section 2: Roles &amp; Responsibilities</b> or <b>Section 6: Forms</b>. <span style="float: right;">Form A5</span></li> <li><input type="checkbox"/> Monitor area for H<sub>2</sub>S and / or LEL with personal monitors and document readings on the Air Monitoring Log. <span style="float: right;">Form A5</span></li> <li><input type="checkbox"/> Report all H<sub>2</sub>S and / or LEL reading changes / increases to the <b>Public Safety Group Supervisor</b>.</li> <li><input type="checkbox"/> For your own safety, ensure the <b>Public Safety Group Supervisor</b> is notified immediately if readings are approaching 10% LEL or 10 ppm H<sub>2</sub>S.</li> <li><input type="checkbox"/> Report any suspicious behaviour to the <b>Public Safety Group Supervisor</b> who will notify the police as required.</li> <li><input type="checkbox"/> Maintain communication with the <b>Public Safety Group Supervisor</b>.</li> </ul> <p style="font-size: small; color: red;"><i>Note: See Section 2: Roles &amp; Responsibilities for a media script for Roadblock and Rover personnel.</i></p>	<p><b>Telephoners</b> are responsible for the notification of impacted residences and businesses to provide public safety instructions.</p> <ul style="list-style-type: none"> <li><input type="checkbox"/> Confirm resident contact lists are available.</li> <li><input type="checkbox"/> Confirm communication links.</li> <li><input type="checkbox"/> In conjunction with the <b>Public Safety Group Supervisor</b>, determine who needs to be notified (residents, businesses, area users, etc.).</li> <li><input type="checkbox"/> Review with the <b>Public Safety Group Supervisor</b> which telephoner scripts to use: Early Notification / Voluntary Evacuation Message, Shelter-in-Place Phone Message, Evacuation Phone Message. <span style="float: right;">Form B6 Form B7 Form B8</span></li> <li><input type="checkbox"/> Contact special needs residents at a Level 1 Emergency and provide them with the option to evacuate.</li> <li><input type="checkbox"/> Contact the other residents and area users in the EPZ and advise them to evacuate or shelter.</li> <li><input type="checkbox"/> Contact the schools / school buses to make arrangements for school age children (if applicable).                             <ul style="list-style-type: none"> <li><input type="checkbox"/> Advise that buses in the affected area leave immediately and that buses should not enter the area.</li> <li><input type="checkbox"/> Request a school administrator for the reception centre to assist in managing the children and releasing them to their guardians.</li> </ul> </li> <li><input type="checkbox"/> Document all resident interactions using the Resident Contact Log and report this information to the <b>Public Safety Group Supervisor</b>. Immediately advise the <b>Public Safety Group Supervisor</b> about unsuccessful contacts and any residents requiring assistance. <span style="float: right;">Form B3</span></li> </ul>
Located at the Incident Command Post (ICP) or the Regional Emergency Operations Centre (REOC).	Location will be assigned.	Location will be the reception centre.	Location will be assigned.	Location will be assigned.	Location will be Incident Command Post (ICP) or Regional Emergency Operations Centre (REOC).

Revised November 2022

Escalate, Downgrade or Stand-Down Levels of Emergency: As the emergency is brought under control, the decision to downgrade the level and/or stand down the emergency will be based on air monitoring readings in consultation with the **Incident Commander** and the applicable government regulator. All affected persons and the media must be kept informed of the status of an emergency. **Emergency Follow-up:** Once the emergency is over, the area residents, transients, industrial users, involved government agencies, and any individual notified will be informed of the stand-down by the **Information Officer** or **Public Safety Group Supervisor**.

## Overview

H<sub>2</sub>S, SO<sub>2</sub>, LEL or other toxic substance concentrations will be monitored continuously during the incident response. It is crucial that **Air Monitors** continuously update the **Public Safety Group Supervisor** with monitored results. If air monitoring readings show high levels of H<sub>2</sub>S, SO<sub>2</sub>, or LEL the **Public Safety Group Supervisor** may need to initiate evacuation / shelter of additional residences, change the location of the roadblocks, or ignite the release.

## Air Monitor Roles

- Obtain and check equipment and information (maps, forms, communications, reports, monitors, safety, and breathing equipment).
- Confirm communication links.
- Monitor closest downwind public location or residence.
- Monitor environment for adverse effects.
- Record all readings on the Air Monitoring Log provided.
- Report all readings at established intervals to the **Public Safety Group Supervisor**.
- For your own safety, ensure the **Public Safety Group Supervisor** is notified immediately if readings are approaching the following levels: 10% LEL or 10 ppm H<sub>2</sub>S.
- Prepare Mobile Monitoring Plan.
- If walking the pipeline right-of-way, walk separately with the wind, staying within visual contact and calling distance. As the lead responder monitors for H<sub>2</sub>S, the backup responder will maintain communication and be prepared to rescue; and
- SO<sub>2</sub> monitoring equipment will be called out as required.
- Document activities using the ICS 214 Activity Log.
- Assist with post-incident activities.
- Monitor H<sub>2</sub>S and LEL concentrations along the edge of the EPZ to determine if sheltering and/or evacuation criteria has been met beyond the EPZ.

## Air Monitoring Equipment

Air monitoring equipment is used to:

- Track the plume.
- Determine if ignition criteria are met.
- Determine whether evacuation and / or shelter-in-place criteria have been met.
- Determine roadblock locations.
- Determine concentrations in areas being evacuated to ensure that evacuation is safe.
- Assist in determining when the emergency can be downgraded.

## Tips

- Air monitors should be dispatched at a Level 1 Emergency.
- Ensure all equipment is operational and the appropriate documentation is available to verify testing and calibration requirements.
- Use the buddy system and equip each responder with reliable monitors and respiratory protective equipment. The monitors must be capable of displaying readings for 1 ppm H<sub>2</sub>S and LEL conditions.
- Breathing apparatus – be prepared to don apparatus quickly.
- Ensure all personnel have a personal gas monitor.
- Speed and direction of wind may vary, therefore, be prepared to track gas plume.
- Record all information:
  - Concentrations in ppm or ppb
  - Location and time of readings
  - Wind speed and direction

## Air Monitoring Log - Example

Time	Location of Samples	H <sub>2</sub> S (ppm)	LEL (%)	O <sub>2</sub> (%)	SO <sub>2</sub> (ppm)	Other	Temp (°C)	Wind Conditions *		Comments
								From	Speed (km/hr)	
19:06	12-05-13-16 W5M	5	4		10		19	NW	12	Picked up 5 ppm reading upon entering lease access. Contacted control room at plant.
19:15	12-05-13-16 W5M	6	7		12		18	NW	11	H <sub>2</sub> S reading increased 1 ppm at the access point.
19:25	12-05-13-16 W5M	6	7		12		17	NW	11	No change in readings. Wind and temperature is down.

\* Estimate meteorological conditions where accurate readings are not available.

## Regulatory Requirements

### Drilling & Completions

#### Critical / Special Sour Wells

If the EPZ includes a portion of urban density development or urban centre:

- There must be minimum of two mobile air monitors:
  - One to monitor the boundary of the urban density development or urban centre and the other to track the plume.
- Ensure that one unit is in the area during drilling and / or completion, testing, and workover operations in potentially critical sour zones.
- Dispatch a mobile air quality monitoring unit(s) at a level 1 emergency and request additional units as required.
- Dispatch a mobile air quality monitoring unit(s) when it is evident that well control measures are deteriorating and that a sour gas release is likely to occur.
- Prior to conducting operations in the sour zone, determine where the monitoring equipment is located and what the estimated travel time is to the well site.

If the EPZ **DOES NOT** include a portion of urban density development or urban centre:

- Dispatch a mobile air quality monitoring unit(s) at a level 1 emergency and request additional units as required.
- Dispatch a mobile air quality monitoring unit(s) when it is evident that well control measures are deteriorating and that a sour gas release is likely to occur.
- Prior to conducting operations in the sour zone, determine where the monitoring equipment is located and what the estimated travel time is to the well site.

#### Continuous Detection Devices

A continuous H<sub>2</sub>S/LEL system must be used while in the critical sour zone. The detection system requirements are as follows:

- A minimum of four sensors able to detect H<sub>2</sub>S concentrations of 5 ppm or greater.
- Audible and visual alarms near the driller's station.
- Set alarms at 10 ppm.
- Locate sensors at the shale shaker, near the bell nipple, on the rig floor, and at the mud mixing unit.

#### Portable Detection Devices

- One portable H<sub>2</sub>S detection device is required while drilling in the critical sour zone.

### Production Operations & General Information

#### Sour Gas Release

- If notified of a release by alarm or by a reported odour, the licensee must investigate the source of the release and dispatch air monitors upon confirmation of the release location or when it is evident that spill control measures are not effective.
- Air quality monitoring occurs downwind with priority being directed to the nearest un-evacuated residence or area where people may be present.
- Air monitors (personal handheld, stationary, and mobile) should be dispatched at a level 1 emergency.
- Dispatch a mobile air quality monitoring unit(s) when it is evident that spill control measures are not effective and that a sour gas release is likely to occur.
- Licensee personnel will monitor and record the concentrations until a mobile air monitoring unit arrives or until the incident is over. At minimum, these readings must include LEL and H<sub>2</sub>S.
- If a sour gas release has been ignited, the licensee should continue to monitor response zones for H<sub>2</sub>S from incomplete combustion, as well as SO<sub>2</sub>.
- The licensee is expected to provide monitored H<sub>2</sub>S and SO<sub>2</sub> information on a regular basis throughout a sour gas emergency to the relevant government regulator, environmental agency, health authority, local authorities, and on request to the public.

#### HVP Product Release

- Air quality monitoring may occur downwind or upwind depending on how the plume is tracking, with priority being directed to the nearest un-evacuated residence or areas where people may be present.
- The licensee is expected to provide monitored HVP product LEL information on a regular basis throughout the emergency to the relevant government regulator, environmental agency, health authority, local authorities, and on request to the public.

#### Downgrading Level of Emergency

- The decision to downgrade an incident will be based on the air monitoring results.

## 1. Choosing a Position

1. Using your map and the current wind conditions, travel downwind, with priority being directed to the nearest un-evacuated residence or area where people may be present.
2. Confirm the location with the **Public Safety Group Supervisor** and make sure you have a safe route to the assigned location that does not cross the hazardous area.

## 2. Record Information

- Record information on the following forms located within this Section:
- Air Monitoring Log
  - ICS 214 Activity Log

## Reporting and Contacts

**Air Monitors** report to the **Public Safety Group Supervisor**.

Name: \_\_\_\_\_

Phone Number: \_\_\_\_\_

Reception Centre

Location: \_\_\_\_\_

Phone Number: \_\_\_\_\_

Wind Direction: \_\_\_\_\_



## Overview

In the event of an emergency in which residents need to be evacuated, a Reception Centre must be established to receive and register the evacuees. A **Reception Centre Representative** is assigned to manage / coordinate activities at the Reception Centre. The **Reception Centre Representative** continuously updates the **Public Safety Group Supervisor** with a list of those who have, and have not, checked in at the Reception Centre.

## Reception Centre Rep Roles

- Confirm Reception Centre is available for use.
- Establish Reception Centre.
- Confirm communication links.
- Receive evacuees and maintain a Reception Centre Registration Log. Form B1
- Arrange for food and accommodations for the evacuees.
- Provide evacuees with a place to request counselling services, if required.
- Record and follow up on all evacuees who choose to make their own accommodation arrangements. Form B2
- Arrange for temporary care of livestock (if possible) and the security of evacuated property.
- Establish and oversee compensation administration activities at the reception centre.
- Reimburse evacuees for their immediate out-of-pocket expenses and log details on a Resident Compensation Log.
- Where possible, provide evacuees with information regarding their property, livestock, and the incident.
- Forward all media and incident inquiries to the **Information Officer**. Form C2
- Report all names of evacuees who have registered at the Reception Centre to the **Public Safety Group Supervisor**.
- Document activities using the ICS 214 Activity Log. Form ICS 214
- Assist with post-incident activities.
- Confirm information to be released to public with the **Information Officer**.
- Address resident concerns and forward them to the **Public Safety Group Supervisor**.

## 1. Choosing a Reception Centre

- Reception Centres are usually located in schools, hotels / motels, or community halls.
- It may be useful to coordinate the location of the Reception Centre with the local authority (city, town, county, M.D., etc.).
- See Area Specific Information (white tabs) for pre-identified Reception Centres in your area.

A Reception Centre should:

- Have a conference room of some type where a large number of people can gather.
- Have conferencing services including fax machine, internet access, and phone access.
- Be large enough to house all of the evacuees.
- Be outside of the hazard area.
- Allow residents to evacuate to the Reception Centre without travelling through the hazard area.
- Allow pets.

## Tips

- Ensure you have enough staff to handle the needs of all of the evacuees.
- Allow evacuees to vent their emotions.
- Do not make any promises that cannot be kept.
- Attempt to reunite families as quickly as possible.
- Document the details of anyone who may have trouble coping with the incident so that they can be given proper psychological support.
- Monitor whether residents that have been contacted by the **Telephoners, Rovers, and Roadblock** personnel have checked in at the Reception Centre.

## 2. Reception Centre Feedback Loop

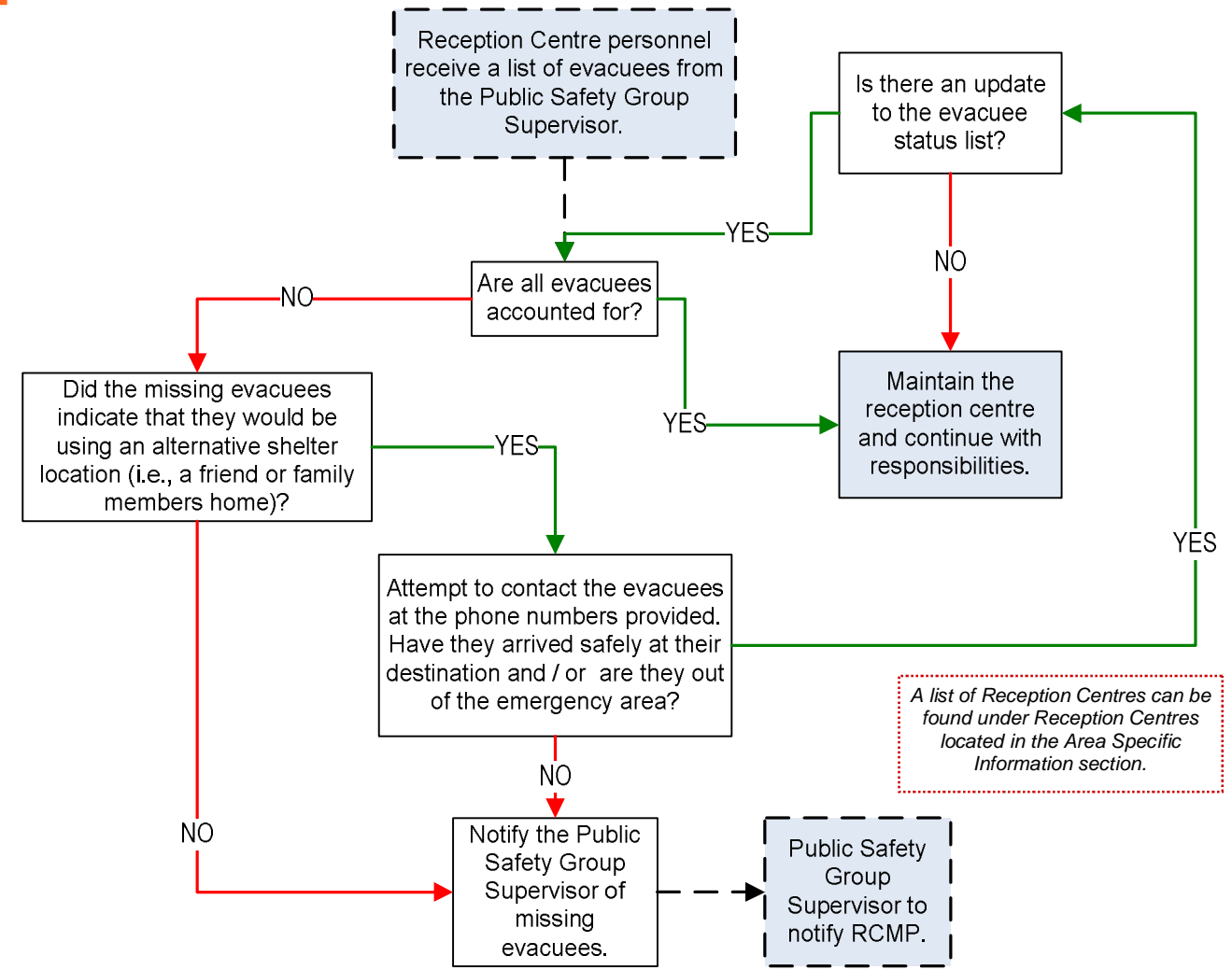

## Reception Centre Registration Log - Example

Resident ID	Name (List all names in party)		# of Occupants	Number Arrived	Arrival Time	Depart Time	Destination Phone # (Where they can be reached)	Comments
	First	Last						
G124-A	John	Doe	2	2	19:06	19:21	555-555-5555	John and his wife arrived safely then left to stay at a friend's house in Red Deer.
H131-B	Jane	Doe	3	3	19:12	19:28	555-555-5555	Jane and her 2 children arrived safely then left to stay with her mother in Bentley.
F122-A	James	Doe	5	3	19:20		555-555-5555	James, his wife and 1 child arrived safely. The other two children are away on a school trip. They will stay at the reception centre for the night.

## Media Statement

Refer all media inquiries to the Media Representative in Calgary. However, if they insist on a statement, please use the following:

**"We can confirm an incident occurred at Ovintiv's [insert facility/site]. Our team in the field is actively responding and we are gathering more information about the nature and severity of the incident. An Ovintiv spokesperson will provide more information when it is available.**

**You can contact our media spokesperson at (281) 210-5253**

Note: See Section 3.0 Communication & Media for more information on media.

## 3. Record Information

Record information on the following forms located within this Section:

- Reception Centre Registration Log
- Resident Compensation Log
- ICS 214 Activity Log
- Media Contact Log

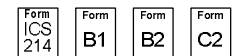

## Reporting and Contacts

Reception Centre Reps report to the **Public Safety Group Supervisor**.

Name: \_\_\_\_\_

Phone Number: \_\_\_\_\_

Reception Centre

Location: \_\_\_\_\_

Phone Number: \_\_\_\_\_

Wind Direction: \_\_\_\_\_



## Overview

In the event of an emergency, roadblock locations and road detours will be established. The company will initially establish and maintain roadblocks until relieved by highway maintenance contractors or the RCMP. **Roadblock** personnel will be assigned in teams of two, one member to stop approaching traffic, the other will record the information gathered and relay to The Public Safety Group Supervisor. The **Public Safety Group Supervisor** must be continuously updated by **Roadblock** personnel so that all vehicles entering and exiting the EPZ are accounted for.

## Roadblock Personnel Roles

- In conjunction with the **Public Safety Group Supervisor**, determine the need for and location of roadblocks.
- Pickup and check roadblock kits.
- Proceed to roadblock locations.
- Determine driving directions to assigned roadblock location that does not have you pass through the hazard area.
- Confirm communication links and establish communication interval times.
- Establish roadblocks to secure the EPZ.
- Follow the scripts and procedures in the ERP.
- If media personnel show up at your roadblock, forward all requests to your direct supervisor who'll direct them to the **Information officer** or **Corporate Comm/Media team**.
- Knowledge and ability to communicate safest route away from hazard.
- Monitor area for H<sub>2</sub>S and / or LEL with personal monitors and document readings on the Air Monitoring Log. Form A5
- Report all reading changes / increases to the **Public Safety Group Supervisor**.
- For your own safety, ensure the **Public Safety Group Supervisor** is notified immediately if readings are approaching 10% LEL and / or 10 ppm H<sub>2</sub>S.
- Move location of Roadblock immediately if readings are approaching 10% LEL and / or 10 ppm H<sub>2</sub>S. Form B4
- Record all incoming and outgoing traffic, personnel, and equipment on the Roadblock Log.
- Forward information given to you by people passing through your location to the **Public Safety Group Supervisor**. Form ICS 214
- Document activities using the ICS 214 Activity Log.
- Report any person that insists on going through the roadblock into the hazard area as well as any suspicious activity to the **Public Safety Group Supervisor**.
- Maintain communication with the **Public Safety Group Supervisor**.
- Maintain roadblock locations. Do not leave until requested to do so by the **Public Safety Group Supervisor** or until relieved by other **Roadblock** personnel.
- Assist with post-incident activities.

## Roadblock Kit Contents - Sample

The roadblock kit may contain the following items:

### Recommended

- Direct communication capability (radio, cell phone, etc.)
- ERP maps and roadblock forms
- Flashlight and batteries
- High visibility / reflective vests
- Orange traffic cones / reflectors
- Pens and / or pencils
- Personal Air Monitoring Device (H<sub>2</sub>S, CO, O<sub>2</sub>, LEL)
- Portable rotating emergency light
- SCBA
- Hand-held stop sign with reflective tape
- Waterproof bag

### Optional

- Caution tape
- Rain suit
- Road barrier

## Tips

- When talking to motorists at the roadblock, **ONLY** provide them with the information as directed by the **Public Safety Group Supervisor**.
- Ask for identification prior to granting access.
- You do not have the legal authority to restrict access to the area without an order from the relevant authority. Report any person who chooses to proceed, without permission, through the roadblock.
- Check with the motorists and ensure all members of their residence are accounted for and documented on the Resident Contact Log. Report any resident that is left behind in the EPZ. Form B3
- The roadblock should be setup to allow optimal visibility and sufficient distance for traffic to come to a safe and complete stop.
- Roadblock** personnel should be highly visible on the side of the road and have an escape route in case of an emergency.
- DO NOT** leave your position until you are directed to do so.

## Choosing a Roadblock

1.

Roadblocks should be established:

- Approximately where the EPZ intersects any highways / roads.
- Outside of the hazard area.
- At a conspicuous location where the **Roadblock** personnel will be visible to approaching traffic, providing them with enough time to safely stop.
- At a location where traffic can easily turn around or detour (consider the potential for larger vehicles such as buses, semi-trailers, drilling rigs, etc.).
- Where possible at natural roadblock locations (e.g., gates, bridges, junctions, etc).

## Before Departure

2.

- Make sure your vehicle is equipped and suitable for the travel conditions.
- Check roadblock kit to confirm all items are present (see sample of roadblock kit contents to left).
- Confirm that your handheld monitor for H<sub>2</sub>S and / or LEL is functioning properly.
- Check all communications devices.
- Check that the red signaling baton flashlight is working and has spare batteries.
- Confirm that you have enough copies of the Roadblock Log form.
- Confirm the location of the roadblock with the **Public Safety Group Supervisor** and make sure you have a safe route to the assigned location that does not cross the hazardous area.

## Setting up a Roadblock

3.

- Park vehicle as illustrated, activating four way flashers and roof mounted rotating beacon.
- Put on reflective vests.
- Take a reading with your handheld monitor for H<sub>2</sub>S and / or LEL; ensuring your roadblock is not too close to the edge of the EPZ. Record readings on the Air Monitoring Log.
- Notify the **Public Safety Group Supervisor** once your roadblock is set up.
- Continue to monitor and record H<sub>2</sub>S and / or LEL levels at scheduled intervals. Report to the **Public Safety Group Supervisor** at scheduled intervals.
- Maintain roadblock until the emergency is over and the "all clear" message is given or until relieved by other **Roadblock** personnel.

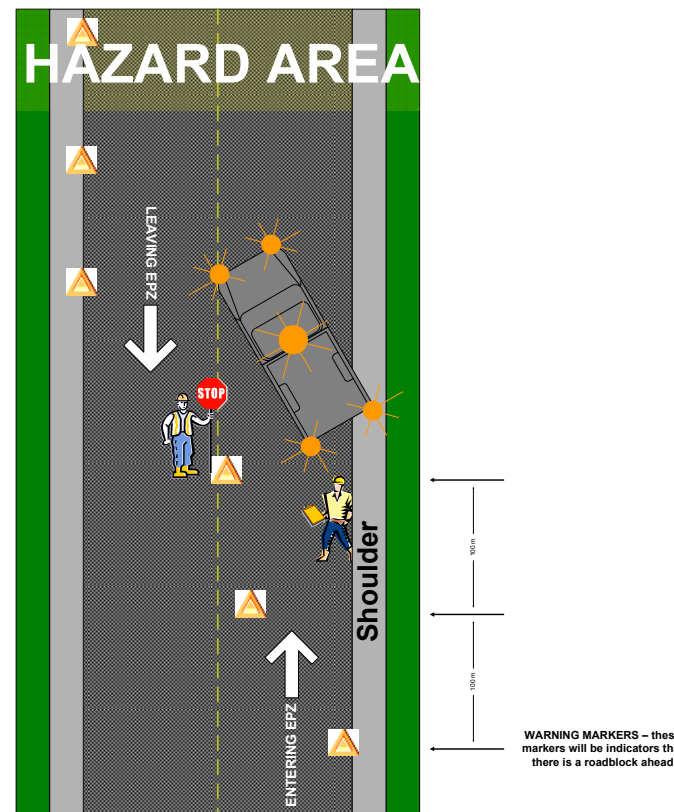

## Reporting and Contacts

Roadblock personnel report to the **Public Safety Group Supervisor**.

Name: \_\_\_\_\_

Phone Number: \_\_\_\_\_

Reception Centre

Location: \_\_\_\_\_

Phone Number: \_\_\_\_\_

Wind Direction: \_\_\_\_\_

To give motorists time to prepare to come to a stop, it is recommended that the **Roadblock** personnel set up all available collapsible reflective triangles 100 metres apart, at a minimum distance of 200 metres before the roadblock.

**Roadblock** personnel cannot force an evacuation or restrict access to the area unless proper authority has been granted. The authority for forced evacuation is gained only through the declaration of a State of Local Emergency by the local authority.

When establishing a roadblock consider:

- Visibility
- Distance
- Bends in the road
- Level of the ground

Remember to:

- Remain calm
- Be courteous
- Record names
- Notify the **Public Safety Group Supervisor**

## How to Stop Traffic

4.

1. Hold the reflective stop / slow paddle erect and away from your body. Never wave the sign.
2. Look directly at the approaching driver.
3. Raise your free arm with the palm of your hand exposed to the driver.
4. Bring the vehicle to a full stop.
5. After the first vehicle has stopped, move to a spot (near the centre line of the roadway) where you can be seen by other approaching vehicles.

Because visibility is reduced at night, it is important that you use utmost care when stopping traffic through a roadblock area, and that you protect yourself from injury by:

- Standing in a safe position on the shoulder of the road.
- Waving the red signaling baton flashlight back and forth.

*Note: The red signaling baton flashlight should only be used in place of the reflective stop / slow paddle at night or in conditions of low / poor visibility.*

## Roadblock Script

5a.

**"I am representing Oventiv and we are presently experiencing control problems ahead. This situation is serious enough to warrant restricted access beyond this point. For your own safety I must ask you not to proceed."**

**Note:**

- ◆ Record driver's name, vehicle make, colour, etc. and at least the license plate number of all vehicles approaching your roadblock; also make a note of the time and of the direction the vehicle took when leaving (e.g., east, south, west, north) on your log sheet.
- ◆ Remember you have no legal position to restrict access to the general public. You are there to protect and notify – to protect the health and safety of the people by notifying them of the danger and secondly to protect the property of the residents who have evacuated the area.
- ◆ Should someone continue into the restricted area, regardless of your warning about personal safety, then use the 2-way radio or cell phone to notify the **Public Safety Group Supervisor** and the matter shall be immediately turned over to the Police.

## Media Statement

5b.

If the media arrives at your roadblock location, company personnel may give the following statement:

**"We can confirm an incident occurred at Oventiv's (insert facility / site). Our team in the field is actively responding and we are gathering more information about the nature and severity of the incident. If you would like to leave your business card or phone number, an Oventiv representative will provide you with more information as it becomes available."**

Contact the **Public Safety Group Supervisor** if a media representative arrives at your roadblock.

**NEVER** offer your opinion of what is happening at the location to a media person or stranger. This can be interpreted as the company's position. **DO NOT** give statements, other than the above message, regarding the emergency situation to the MEDIA. Refer them to the Information Officer.

**Be courteous but firm.**

**If the questioning persists, just keep politely repeating word for word the statement above.**

## Record Information

6.

Record information on the following forms located within this section:

- Roadblock Log
- Resident Contact Log
- Air Monitoring Log
- ICS 214 Activity Log

Form ICS 214

Form A5

Form B3

Form B4

**Possible Scenarios for Roadblock Personnel:**

- ◆ Motorist obeys request and drives away from the EPZ.
- ◆ Motorist is leaving the EPZ and agrees not to return until further notice.
- ◆ Emergency responders (service companies, fire, ambulance, etc.) are entering the EPZ to help respond to the incident.
- ◆ Motorist disobeys request to leave the area and enters the EPZ.

In all cases, notify the **Public Safety Group Supervisor** and log all information.



## Overview

**Rovers** are responsible for patrolling the Emergency Planning Zone to locate and notify residents, businesses, industrial operators, transients (i.e. hunters, trappers, recreational users, non-resident landowners), and the general public. This may be completed via truck, ATV, boat, helicopter, etc. The **Public Safety Group Supervisor** must be continuously updated by the **Rovers** so that unsuccessful attempts to evacuate residents, transients, etc. can be followed up on immediately.

## Rover Personnel Roles

- Confirm resident contact lists are available.
- Confirm communication links.
- Know safe routes in and out of the EPZ.
- Search for residents and transients in the Emergency Planning and Response Zones.
- Check all buildings including barns, shops, sheds, etc.
- Assist, as required, with the notification, evacuation or sheltering of persons within the Emergency Planning Zone. Record all contact with residents using the Resident Contact Log. Form B3
- Post Evacuation Notices for residents that are not at their residence. Form B5
- Follow the scripts and procedures in the ERP.
- Monitor area for H<sub>2</sub>S and / or LEL with personal monitors and document readings on the Air Monitoring Log. Form A5
- Report all reading changes / increases to the **Public Safety Group Supervisor**.
- For your own safety, ensure the **Public Safety Group Supervisor** is notified immediately if readings are approaching the following levels: 10% LEL and / or 10 ppm H<sub>2</sub>S.
- Report any suspicious behaviour to the **Public Safety Group Supervisor** who will notify the police as required.
- Document all activities using the ICS 214 Activity Log. Form ICS 214
- Maintain communication with the **Public Safety Group Supervisor**.
- Assist with post-incident activities.

## Media Statement

If a media representative approaches you, company personnel may give the following statement:

**“We can confirm an incident occurred at Ovintiv’s (insert facility / site). Our team in the field is actively responding and we are gathering more information about the nature and severity of the incident. If you would like to leave your business card or phone number, an Ovintiv representative will provide you with more information as it becomes available.”**

Contact the **Public Safety Group Supervisor** if a media representative approaches you.

**NEVER** offer your opinion of what is happening at the location to a media person or stranger. This can be interpreted as the company’s position. **DO NOT** give statements, other than the above message, regarding the emergency situation to the MEDIA. Refer them to the Information Officer.

**Be courteous but firm.**

**If the questioning persists, just keep politely repeating word for word the statement above.**

## Reporting and Contacts

**Rovers** report to the **Public Safety Group Supervisor**.

Name: \_\_\_\_\_

Phone Number: \_\_\_\_\_

Reception Centre: \_\_\_\_\_

Location: \_\_\_\_\_

Phone Number: \_\_\_\_\_

Wind Direction: \_\_\_\_\_

## Evacuation Notice - Example

Form  
B5

DATE: \_\_\_\_\_

TIME: \_\_\_\_\_

# EVACUATION NOTICE

*[Insert Company Name]* has an emergency at its nearby location.

As a safety precaution, please leave the area in a (north / east / south / west) direction and proceed to the Reception Centre located at \_\_\_\_\_.

*[Insert Company Name]* representatives will be available at the Reception Centre to address your questions or concerns.

For assistance, call *[Insert Company Name]* at \_\_\_\_\_.

Thank you

## Tips

Remember to:

- Remain calm
- Be courteous
- Document all actions and comments
- Notify the **Public Safety Group Supervisor**

Remember to use a handheld H<sub>2</sub>S and / or LEL monitor to continually test the atmosphere. Report all H<sub>2</sub>S and / or LEL reading changes / increases to the **Public Safety Group Supervisor**.

Response personnel cannot force an evacuation or restrict access to the area unless proper authority has been granted. The authority for forced evacuation is gained only through the declaration of a State of Local Emergency by the local authority.

## 1.

### Before Departure

- Protect yourself
- Ensure you are equipped with all necessary equipment:
  - SCBA
  - Gas monitors
  - Mobile communications or other form of communication
  - Forms
  - Vehicle (4x4) with full tank of fuel
  - Map
- Confirm that your handheld monitor for H<sub>2</sub>S and / or LEL is functioning properly.
- Confirm that you have enough copies of the Evacuation Notice.
- Confirm your assignments with the **Public Safety Group Supervisor** and make sure you have a safe route to the assigned location that does not cross the hazardous area.

## 2.

### Notifying Residents / Transients

The **Public Safety Group Supervisor** may request you to patrol the Emergency Planning and Response Zones in search of transients (people passing through the area) and / or residents that couldn't be reached by phone. Make contact with residents / transients and after providing an explanation record their names, contact information, purpose for being in the area (travelling through, live in the area, etc.), current condition, timing of your arrival, and whether or not they require evacuation assistance.

**“Hi, I am *[Insert Name]* representing *Ovintiv*. The company is presently experiencing control problems at a nearby location. The situation is serious enough that we are evacuating the public in the area. For your own safety I must ask you to leave the area immediately and check in with a company representative at the Reception Centre. Representatives at the Reception Centre will address any questions you may have and will make arrangements for your temporary accommodations.”**

- Ask if they will require evacuation assistance and arrange additional transportation assistance if necessary.
- Make sure they are all accounted for.
- Ensure they gather any supplies they will need for the next 24 hours (medicines, baby food, diapers, etc.).
- If they are able to transport themselves to the Reception Centre provide them with directions that will keep them away from the hazard.
- Ask them if they have any questions.
- Provide them with your name and contact information in case they need assistance later.
- Report to the **Public Safety Group Supervisor**.

## 3.

### Requested Evacuation Assistance

The **Public Safety Group Supervisor** may request you to provide evacuation assistance for residents that have requested it. Ensure you obtain the number of residents requiring assistance, resident's names, location (legal and address), and the reason evacuation assistance is required (medical issue, children home alone, etc). A **Telephoner** should have already contacted and explained the situation to the residents; however, it is a good idea to confirm with the **Public Safety Group Supervisor** that they know you are coming to assist them. If they have not already been informed, contact the resident to tell them you are on your way and provide an estimated time of arrival.

**“Hi, I am *[Insert Name]* representing *Ovintiv*. I am here to help you evacuate out of the hazard area and make sure you arrive safely at the Reception Centre. A company representative at the Reception Centre will address any questions you may have and will make arrangements for your temporary accommodations.”**

- Try not to scare them. They are aware you might be coming but don't know what to expect.
- Make sure they are all accounted for.
- Ensure they gather any supplies they will need for the next 24 hours (medicines, baby food, diapers, etc.).
- Ask them if they have any questions.
- Once you are satisfied that all personnel from the residence are accounted for, deliver them to the Reception Centre.
- On the way to the Reception Centre, notify the **Public Safety Group Supervisor** of your progress and estimated time of arrival at the Reception Centre.
- Ensure that the residents check in at the Reception Centre with the **Reception Centre Representative** before you leave for your next assignment.

## 4.

### Record Information

Record information on the following forms located within this section:

- Resident Contact Log
- Air Monitoring Log
- ICS 214 Activity Log
- Evacuation Notice

Form ICS 214   Form A5   Form B3   Form B5



## Overview

In the event of an emergency in which residents and area users need to be sheltered and / or evacuated, a team of **Telephoners** will be established to contact people in the area and provide instructions to ensure their safety. The **Public Safety Group Supervisor** must be continuously updated with the **Telephoners** progress so that unsuccessful contact attempts and requests for evacuation assistance can be followed up on immediately.

## Telephone Personnel Roles

- Confirm resident contact lists are available.
- Confirm communication links.
- In conjunction with the **Public Safety Group Supervisor**, determine who needs to be notified (residents, businesses, area users, etc.).
- Review with the **Public Safety Group Supervisor** the telephoner scripts to be used: Early Notification / Voluntary Evacuation Message, Shelter-in-Place Phone Message, Evacuation Phone Message.
- Contact special needs residents at a Level 1 Emergency and provide them with the option to evacuate.
- Contact the other residents and area users in the EPZ and advise them to evacuate or shelter.
- Contact the schools / school buses to make arrangements for school age children (if applicable).
  - Advise that buses in the affected area leave immediately and that buses should not enter the area.
  - Request a school administrator for the reception centre to assist in managing the children and releasing them to their guardians.
- Document all resident interactions using the Resident Contact Log and report this information to the **Public Safety Group Supervisor**. Immediately advise the **Public Safety Group Supervisor** about unsuccessful contacts and any residents requiring assistance.
- Document all activities using the ICS 214 Individual Activity Log.
- Assist with post-incident activities.

Form B6

Form B7

Form B8

Form B3

Form ICS 214

## Shelter-In-Place Instructions

- Immediately gather everyone indoors and stay there. Do not leave even if you see people outside.
- Close and lock all outside doors and windows. Tape gaps around doors and windows. Leave all inside doors open.
- Turn off appliances or equipment that blows out indoor air or sucks in outside air.
- Turn down furnace thermostats to the minimum setting and turn off air conditioners.
- Extinguish all potential sources of ignition (do not smoke or attempt to start your vehicle).
- Stay off of the phone so that you can be contacted by emergency personnel.
- Stay tuned to local radio and television for possible updates.

Note: For the full Shelter-In-Place instructions see page 2 of the Shelter-In-Place Telephoner Text form located in SECTION 6.0: FORMS.

Form B7

## 1. Who to Contact

- Residents
- Schools / School Bus Transportation
- Businesses
- Public Facilities
- Recreation Areas
- Urban Centres (contact local authority to coordinate)
- Area Users (other oil and gas operators, rail, logging, etc.)
- Trappers
- Guides / Outfitters
- Grazing Lease / Allotment Holders

Priority is given to:

- Those closest to the hazard
- Those downwind of the hazard
- Those with sensitivity issues (health issues, require assistance, etc.)

## Tips

- Ensure you have enough personnel to quickly and efficiently shelter / evacuate the required residents / area users.
- A general guideline is to have one **Telephoner** for every seven residences that need to be contacted and one **Telephoners Leader** for every ten **Telephoners**.
- Special needs residents should be contacted at a Level 1 Emergency and given the option to evacuate.

Response personnel cannot force an evacuation or restrict access to the area unless proper authority has been granted. The authority for forced evacuation is gained only through the declaration of a Local State of Emergency by the local authority.

## 2a. Shelter-In-Place Phone Message

Hello, this is \_\_\_\_\_ (your name) of \_\_\_\_\_ (company name).  
Is this the \_\_\_\_\_ (name) residence at \_\_\_\_\_ (telephone number) ?  
\_\_\_\_\_ (company name) is responding to a (potential) emergency at \_\_\_\_\_ (location) in your area.

For your safety, it is extremely important that you, and those with you, stay indoors until the potential hazard no longer exists, or you are advised to evacuate.

To help us understand your immediate needs, we need to know:

**How many people are at your location now?**

Adults \_\_\_\_\_  
Children \_\_\_\_\_

Is there anyone in your household that you cannot contact to inform them of the situation and advise them to get in doors or stay out of the area?

Yes  No

**IF YES** Whom? \_\_\_\_\_

Location of the person(s) \_\_\_\_\_

We will send someone to find them as soon as possible.

**Do you have children in school at this time?**

Yes  No

**IF YES** What school? \_\_\_\_\_

Children's names \_\_\_\_\_

We will contact the school to ensure the safety of your children. Buses will be directed to leave the area immediately. If school is in session, your children will be redirected to the reception centre by their regular bus driver when the school day is over.

**Do you have the "Shelter-in-Place" instructions previously provided to you by \_\_\_\_\_ (company name) ?**

Yes  No

**IF YES** Please follow the Shelter-in-Place instructions located inside the resident pamphlet.

**IF NO** Verbally walk the resident through the Shelter-in-Place instructions on the next page.

**Do you understand what I have told you?**

**Is there an alternate number we can contact you at?** \_\_\_\_\_

**If you have any urgent questions, please contact \_\_\_\_\_ (company name) at \_\_\_\_\_ (telephone number).**

**Thank you for your cooperation.**

*(Pass on all information regarding this call to the Public Safety Group Supervisor immediately)*

Note: Refer to Shelter-in-Place instructions on page 2 of the Shelter-in-Place Phone Message located in this section.

## Telephoner Communication Flow

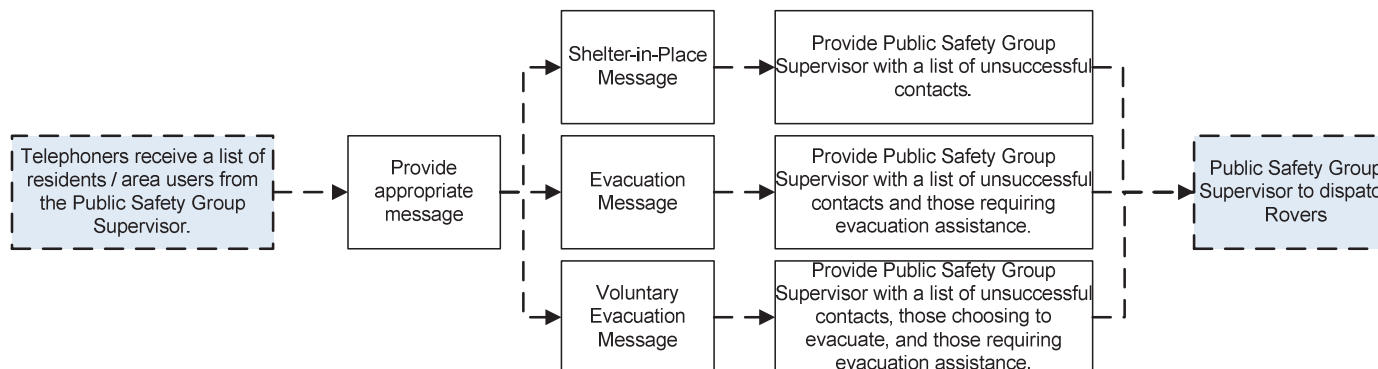

## 2b. Evacuation Phone Message

Hello, this is \_\_\_\_\_ (your name) of \_\_\_\_\_ (company name).  
Is this the \_\_\_\_\_ (name) residence at \_\_\_\_\_ (telephone number) ?  
\_\_\_\_\_ (company name) is responding to a (potential) emergency at \_\_\_\_\_ (location) in your area.

For your safety, it is extremely important that you and your family leave your residence immediately and travel in a **north / east / south / west** direction to our reception centre located at: \_\_\_\_\_

To help us understand your immediate needs, we need to know:

**How many people are at your location now?**

Adults \_\_\_\_\_  
Children \_\_\_\_\_

Is there anyone in your household that you cannot contact to inform them of the situation and advise them to evacuate away from the area?

Yes  No

**IF YES** Whom? \_\_\_\_\_

Location of the person(s) \_\_\_\_\_

We will send someone to find them as soon as possible.

**Do you have children in school at this time?**

Yes  No

**IF YES** What school? \_\_\_\_\_

Children's names \_\_\_\_\_

We will contact the school to ensure the safety of your children. Buses will be directed to leave the area immediately. If school is in session, your children will be redirected to the reception centre by their regular bus driver when the school day is over.

**Do you require evacuation / transportation assistance?**

Yes  No

**IF YES** We are sending someone to assist you. Please stay indoors and close all doors and windows until a Rover or the local police arrive to evacuate you.

**IF NO** Provide the resident with:

- Directions to safely travel to the reception centre
- A list of items to bring with them to the reception centre (medications, cell phone, etc.)
- An idea of how long they may be expected to stay at the reception centre
- The option to bring their house pets to the reception centre

Please contact \_\_\_\_\_ (company name) if you are unable to make it to the reception centre for any reason. Please keep your phone line free so that we can contact you if necessary.

**Is there an alternate number we can contact you at?** \_\_\_\_\_

A company representative at the reception centre will address any questions you may have and will make arrangements for your temporary accommodations. Do you understand everything I have told you? Are you leaving immediately?

**If you have any urgent questions, please contact \_\_\_\_\_ (company name) at \_\_\_\_\_ (telephone number).**

**Thank you for your cooperation.**

*(Pass on all information regarding this call to the Public Safety Group Supervisor immediately)*

## 3. Record Information

Record information on the following forms located within this section:

- Resident Contact Log
- ICS 214 Individual Activity Log
- Voluntary Evac Message
- Shelter-in-Place Message
- Evacuation Message

Form ICS 214 Form B3 Form B6 Form B7 Form B8

## Reporting and Contacts

**Telephoners report to the Public Safety Group Supervisor.**

Name: \_\_\_\_\_

Phone Number: \_\_\_\_\_

Reception Centre Location: \_\_\_\_\_

Phone Number: \_\_\_\_\_

Wind Direction: \_\_\_\_\_



### Initial Response:

All incidents begin with the initial response (reactive phase) during the first operational period. At the onset of an emergency response an Initial Emergency Report (A1) Form is completed to determine the severity of the emergency and extent of the response. 95% of emergency responses begin and end in the first operational period.

After response personnel ensure their own personal safety by following the First On-Scene Actions, the Five Step Initial Response Guide, and associated tools, provide a structure for the Incident Commander to formulate a response and outlines the steps (key considerations) that need to be addressed and re-addressed when evaluating the incident and associated emergency response.

### Ongoing Response:

An ongoing response (proactive phase) is required for an extended emergency response that spans over multiple operational periods and revolves around establishing the objectives, strategies, and tactics for the next upcoming operational period. 5% of incidents require an ongoing response, but once engaged emergency responders will circulate through this cycle multiple times.

After the initial response has been completed, the Five Step Ongoing Response Guide and associated tools provide a cycle to plan the next steps of the emergency response. This continual cycle provides a structure for the Command Staff and General Staff to complete the Incident Action Plan (IAP) and associated documents. The ongoing response cycle and an associated IAP must be completed for each operational period until the incident is stood down.

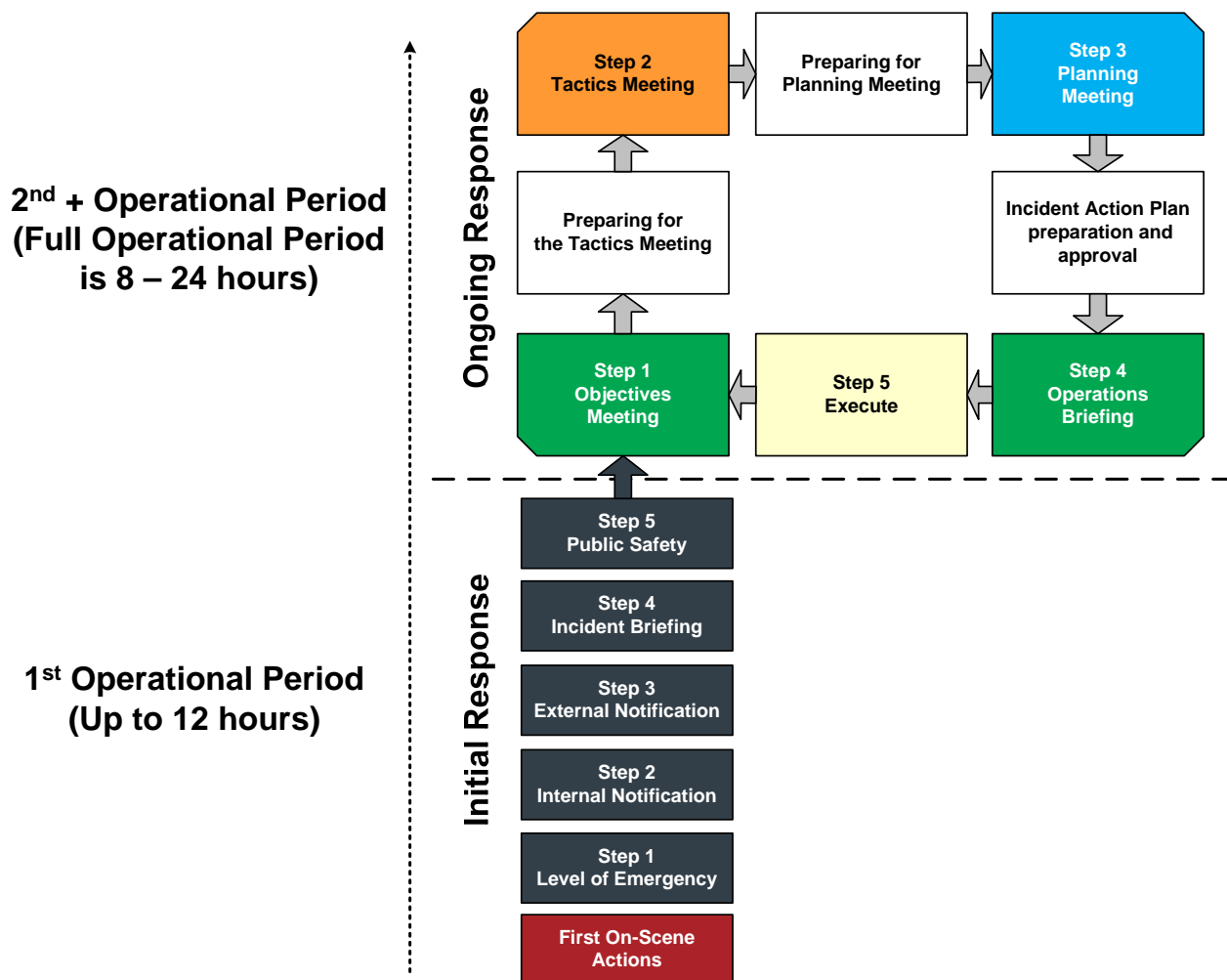

This page is intentionally left blank

### Step 1 - Objectives Meeting

- Incident Commander conducts the meeting.
- Review the ICS 201 form completed during the Initial Response phase and begin the ICS 209 form by evaluating the current incident status.
- Identify issues/problems to resolve using the PPOST methodology.
- Develop SMART (Specific, Measurable, Attainable, Realistic, & Time-Sensitive) objectives to mitigate the identified problems.
- Prioritize the objectives using the ICS 202 form.
- Complete the ICS 202 form and identify initial staffing on the ICS 207 form.
- Utilize IAP Checklist (A4) to complete the IAP.

### Prepare for Tactics Meeting

- Develop draft strategies and tactics for each defined objective.
- Outline work assignments and develop an operations organization chart using the ICS 207 form.
- Identify future tactical plans to optimize the Tactics Meeting.
- Begin to prepare a safety analysis once all hazards have been identified using ICS 215A form.

### Step 2 - Tactics Meeting

- Operations Section Chief conducts the meeting.
- Review the incident status using the ICS 209 form that was completed during the Objectives Meeting.
- Operations Section Chief proposes strategies and tactics.
- Evaluate and assign resources and personnel.
- Ensure that all strategies have associated tactics to ensure responder safety and complete the ICS 215A form.
- Complete the ICS 215 form and update the ICS 207 form started during the Objectives Meeting.

### Prepare for Planning Meeting

- Review and update the ICS 209 form.
- Confirm availability of resources and locations.
- Prepare all information for review at the Planning Meeting.
- Gather any additional incident documentation (i.e., maps and status boards).

### Step 3 - Planning Meeting

- Planning Section Chief conducts the meeting.
- Review the incident status using the updated ICS 209 form.
- Confirm the strategies and tactics assigned to achieve the defined objectives.
- Ensure that all assigned tactics can be performed safely and follow the defined safety analysis using the ICS 215A form.
- Incident Commander to give tentative approval of proposed plan and review with key response personnel.

### Incident Action Plan Preparation and Approval

- Produce a coordinated and sustainable Incident Action Plan using the IAP Checklist (A4), ICS forms 202, 207, 209, 215, 215A, and gather any additional incident documentation (i.e., maps and status boards).
- Receive final approval from the Incident Commander.
- Define work assignments and break the work into manageable units.
- If necessary, other documents may be included such as a Demobilization plan.

### Step 4 - Operations Briefing

- Incident Commander conducts the meeting.
- Provide personnel with work assignments from the IAP.
- Operations Section Chief to brief the organization and provide clarification on all tactical assignments.
- Ensure that all responders know and understand the safety analysis, hazards, and controls.

### Step 5 - Execute

- Perform work assignments according to assigned roles.
- Document all actions, decisions, and conversations.
- Constantly evaluate how well the plan is designed and being conducted.
- Adjust the plan and associated actions accordingly.
- Identify additional objectives for the upcoming operational period.
- Schedule next Objectives Meeting if applicable.

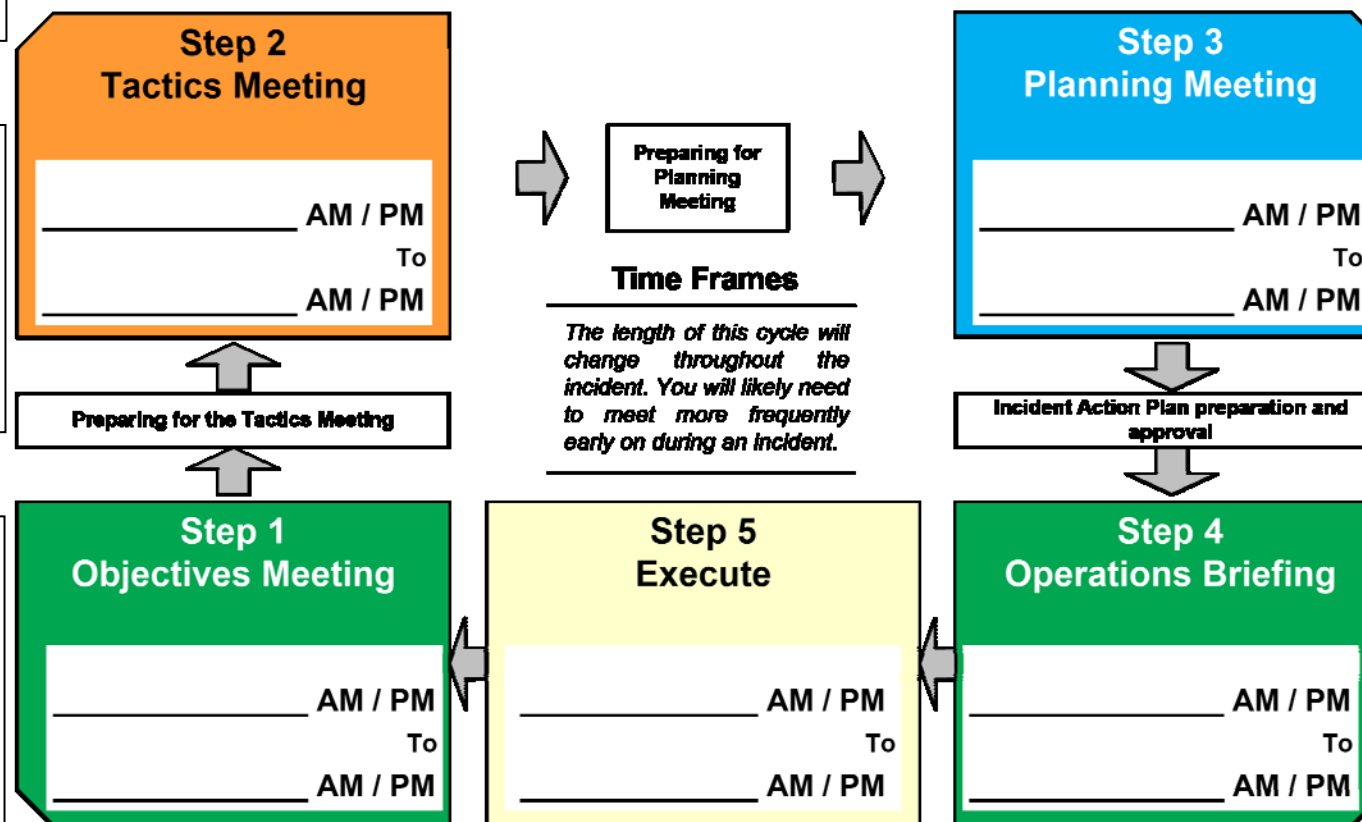
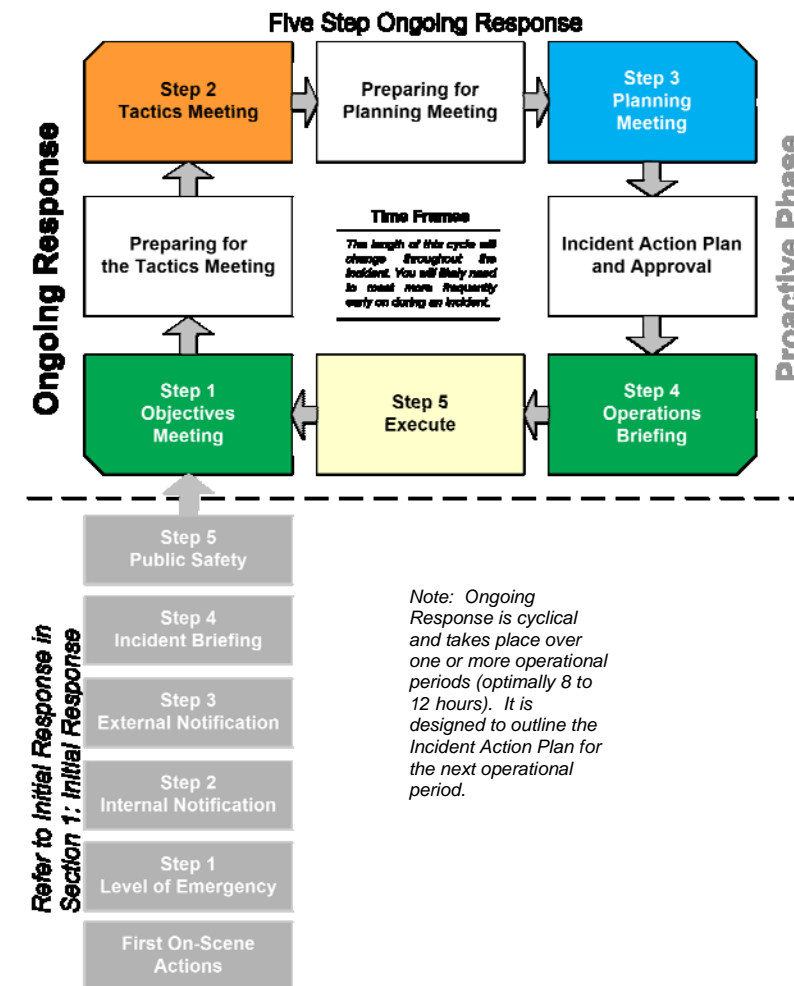

# Five Step Ongoing Response Guide



This page is intentionally left blank

---

<b>Owner: Incident Commander</b>	<b>Date:</b>	<b>Time:</b>
<b>**Roles below will attend only if designated and available**</b>		
<b>Attendees:</b>		
<input type="checkbox"/> <i>Incident Commander:</i>	<input type="checkbox"/> <i>Planning Section Chief:</i>	
<input type="checkbox"/> <i>Deputy Incident Commander:</i>	<input type="checkbox"/> <i>Logistics Section Chief:</i>	
<input type="checkbox"/> <i>Operations Section Chief:</i>	<input type="checkbox"/> <i>Finance/Admin. Section Chief:</i>	
<input type="checkbox"/> <i>Planning Section Chief:</i>	<input type="checkbox"/> <i>Safety Officer:</i>	
<input type="checkbox"/> <i>Liaison Officer:</i>	<input type="checkbox"/> <i>Other:</i>	
<input type="checkbox"/> <i>Information Officer:</i>	<input type="checkbox"/> <i>Other:</i>	
<b>Summary:</b>		
<p>The objectives of this meeting are to:</p> <ul style="list-style-type: none"> <li>• Have a completed <b>ICS 202</b> form agreed upon by all attendees (Command and General Staff).</li> <li>• Establish objectives and priorities for the upcoming operational period.</li> <li>• Begin an <b>ICS 209</b> Incident Status Summary report.</li> <li>• Begin identifying all required roles on the <b>ICS 207</b> form.</li> <li>• Begin addressing the Incident Action Plan Checklist (<b>A4</b>).</li> <li>• Schedule and prepare for the Tactics Meeting.</li> </ul>		
<b>Resources:</b>		
<b>Agenda Items:</b>		
<input type="checkbox"/> Status Update and review the Incident Briefing form.		
<input type="checkbox"/> Determine incident priorities. Reference the PPOST methodology.		
<input type="checkbox"/> Establish an incident organization that is capable of meeting initial and long-term challenges required to mitigate the incident.		
<input type="checkbox"/> Determine the incident response objectives and complete and Incident Objectives form. They must be (Specific, Measurable, Attainable, Realistic, & Time Sensitive).		
<input type="checkbox"/> Identify initial staffing requirements and begin filling out the Incident Organizational Chart.		
<input type="checkbox"/> Identify and select incident support facilities.		
<input type="checkbox"/> Review the incident objectives for the next operational period so your management team can begin work on the IAP.		
<input type="checkbox"/> Document the incident status to relay to all responding personnel.		
<b>Key Points:</b>		
<ul style="list-style-type: none"> <li>• <b>Ensure that the meeting is documented / recorded.</b> (Utilize the back side of this page.)</li> <li>• Define the hours of work and operational period.</li> <li>• Utilize Incident Action Plan Checklist (<b>A4</b>).</li> <li>• Identify constraints and limitations.</li> <li>• Clarify any staff roles and responsibilities.</li> <li>• Determine expectations of the team for how all communications are to be made.</li> <li>• Discuss and agree on process issues such as resource ordering, cost accounting, operations security, and sensitive information.</li> <li>• Continue to develop tasks for Command and General Staff.</li> <li>• Agree on division of command workload, such as press and agency briefings.</li> </ul>		

Notes:

<b>Owner: Operations Section Chief</b>	<b>Date:</b>	<b>Time:</b>
<b>**Roles below will attend only if designated and available**</b>		
<b>Attendees:</b>		
<input type="checkbox"/> <i>Incident Commander:</i>	<input type="checkbox"/> <i>Planning Section Chief:</i>	
<input type="checkbox"/> <i>Deputy Incident Commander:</i>	<input type="checkbox"/> <i>Logistics Section Chief:</i>	
<input type="checkbox"/> <i>Operations Section Chief:</i>	<input type="checkbox"/> <i>Finance/Admin. Section Chief:</i>	
<input type="checkbox"/> <i>Planning Section Chief:</i>	<input type="checkbox"/> <i>Safety Officer:</i>	
<input type="checkbox"/> <i>Liaison Officer:</i>	<input type="checkbox"/> <i>Other:</i>	
<b>Summary:</b>		
<p>The objectives of this meeting are to:</p> <ul style="list-style-type: none"> <li>• Define tactics, work assignments, and resources to meet actions identified during the Objectives Meeting.</li> <li>• Have completed <b>ICS 215</b> and <b>215A</b> forms agreed upon by all attendees (Command and General Staff).</li> <li>• Update the <b>ICS 207</b> Incident Organization Chart.</li> <li>• Refer to Incident Action Plan Checklist (<b>A4</b>) and continue to add to items accomplished.</li> <li>• Schedule and prepare for the Planning Meeting.</li> </ul>		
<b>Resources:</b>	<b>ICS 209, 215, 215A, and IAP Checklist (A4)</b>	
<b>Agenda Items:</b>		
<input type="checkbox"/> Review <b>ICS 209</b> Incident Status Summary.		
<input type="checkbox"/> Review incident objectives.		
<input type="checkbox"/> Define tactics to complete objectives set out during the Objectives Meeting.		
<input type="checkbox"/> Provide an operational update and identify tactics to deal with incident.		
<input type="checkbox"/> Identify roles and responsibilities that have to be performed to implement tactics.		
<input type="checkbox"/> Build on already established <b>ICS 207</b> Incident Organization Chart, check span-of-control, and match up with <b>ICS 215</b> assignments.		
<p>Complete the Operational Planning Worksheet, <b>ICS 215</b> (Utilize one form for every established objective).</p> <ul style="list-style-type: none"> <li><input type="checkbox"/> Identify work assignments</li> <li><input type="checkbox"/> Identify resources requirements to achieve each work assignment</li> <li><input type="checkbox"/> Identify overhead staffing needs to support each work assignment</li> <li><input type="checkbox"/> Identify specialized equipment and supply needs for each work assignment</li> <li><input type="checkbox"/> Specify reporting times and location for personnel</li> </ul>		
<p>Complete the Incident Action Plan Safety Analysis, <b>ICS 215A</b>.</p> <ul style="list-style-type: none"> <li><input type="checkbox"/> Identify potential hazard types</li> <li><input type="checkbox"/> Identify mitigations for associated hazard types</li> </ul>		
<input type="checkbox"/> Identify support facilities and locations.		
<b>Key Points:</b>		
<ul style="list-style-type: none"> <li>• <b>Ensure that the meeting is documented / recorded.</b> (Utilize the back side of this page.)</li> <li>• Review planned actions against incident objectives and priorities.</li> <li>• Utilize a map or chart to depict the operational areas, support facilities, and any key information.</li> <li>• Discuss any applicable open action items.</li> <li>• Consider contingencies and secondary options.</li> </ul>		

Notes:

# Planning Meeting



## Core Emergency Response Plan

<b>Owner: Planning Section Chief</b>	<b>Date:</b>	<b>Time:</b>
<b>**Roles below will attend only if designated and available**</b>		
<b>Attendees:</b>		
<input type="checkbox"/> <i>Incident Commander:</i>	<input type="checkbox"/> <i>Planning Section Chief:</i>	
<input type="checkbox"/> <i>Deputy Incident Commander:</i>	<input type="checkbox"/> <i>Logistics Section Chief:</i>	
<input type="checkbox"/> <i>Operations Section Chief:</i>	<input type="checkbox"/> <i>Finance/Admin. Section Chief:</i>	
<input type="checkbox"/> <i>Planning Section Chief:</i>	<input type="checkbox"/> <i>Safety Officer:</i>	
<input type="checkbox"/> <i>Liaison Officer:</i>	<input type="checkbox"/> <i>Other:</i>	
<input type="checkbox"/> <i>Information Officer:</i>	<input type="checkbox"/> <i>Other:</i>	
<b>Summary:</b>		
<p>The objectives of this meeting are to:</p> <ul style="list-style-type: none"> <li>Finalize an Incident Action Plan with the necessary forms based on the objectives, tactics, and strategies outlined from the previous command meetings.</li> <li>Schedule and prepare for the Operations Briefing.</li> </ul>		
<b>Resources:</b>		
<b>Agenda Items:</b>		
<input type="checkbox"/> Review Incident Action Plan forms ( _____ , and _____ ).		
<input type="checkbox"/> Review Command's incident objectives, priorities, decisions, and direction.		
<input type="checkbox"/> Provide briefing on current situation, resources at risk, weather forecast, and incident projections.		
<input type="checkbox"/> Operations Section Chief provides briefing on: <ul style="list-style-type: none"> <li><input type="checkbox"/> Current operations.</li> <li><input type="checkbox"/> An overview on the proposed plan including strategy, tactics or work assignments, resource commitment, contingencies, organization structure, and needed support facilities.</li> </ul>		
<input type="checkbox"/> Review the proposed plan to ensure that Command direction, priorities, and operational objectives are met.		
<input type="checkbox"/> Delegate assignments and deadlines to appropriate staff members to assure timely and effective IAP development.		
<b>Key Points:</b>		
<ul style="list-style-type: none"> <li><b>Ensure that the meeting is documented / recorded.</b> (Utilize the back side of this page.)</li> <li>Review IAP Checklist ( _____ ) to ensure that all critical materials have been accounted for in the IAP.</li> <li>Planning Section Chief brings meeting to order, cover ground rules, and review agenda.</li> <li>Planning Section Chief requests tacit Command approval of the plan as presented.</li> <li>Planning Section Chief reviews and validates responsibility for any open actions and management objectives.</li> <li>Planning Section Chief conducts round table of Command and General Staff to solicit their final input and commitment to the proposed plan.</li> </ul>		

Notes:

<b>Owner: Incident Commander</b>	<b>Date:</b>	<b>Time:</b>
<b>**Roles below will attend only if designated and available**</b>		
<b>Attendees:</b>		
<input type="checkbox"/> <i>Incident Commander:</i>	<input type="checkbox"/> <i>On-Site Group Supervisor</i>	
<input type="checkbox"/> <i>Deputy Incident Commander:</i>	<input type="checkbox"/> <i>Public Safety Group Supervisor</i>	
<input type="checkbox"/> <i>Operations Section Chief:</i>	<input type="checkbox"/> <i>Air Monitor Team Lead</i>	
<input type="checkbox"/> <i>Planning Section Chief:</i>	<input type="checkbox"/> <i>Roadblock Team Lead</i>	
<input type="checkbox"/> <i>Liaison Officer:</i>	<input type="checkbox"/> <i>Rover Team Lead</i>	
<input type="checkbox"/> <i>Information Officer:</i>	<input type="checkbox"/> <i>Telephoner Team Lead</i>	
<input type="checkbox"/> <i>Planning Section Chief:</i>	<input type="checkbox"/> <i>Reception Centre Representatives</i>	
<input type="checkbox"/> <i>Logistics Section Chief:</i>	<input type="checkbox"/> <i>Other:</i>	
<input type="checkbox"/> <i>Finance/Admin. Section Chief:</i>	<input type="checkbox"/> <i>Other:</i>	
<input type="checkbox"/> <i>Safety Officer:</i>	<input type="checkbox"/> <i>Other:</i>	
<input type="checkbox"/> <i>Staging Area Manager:</i>	<input type="checkbox"/> <i>Other:</i>	
<b>Summary:</b>		
<p>The objectives of this meeting are to:</p> <ul style="list-style-type: none"> <li>• Review a summary of the incident status with all responders.</li> <li>• Relay objectives, tactics, and strategies.</li> <li>• Reinforce/relay the safety message.</li> <li>• Assign roles &amp; responsibilities and tasks for all responders to accomplish.</li> <li>• Execute the response.</li> <li>• Tentatively schedule next Objectives Meeting and identify potential problems/issues to address in the next operational period.</li> </ul>		
<b>Resources:</b>		
<b>Agenda Items:</b>		
<input type="checkbox"/> Planning Section Chief briefly walks through the IAP components and makes changes as needed.		
<input type="checkbox"/> Operations Section Chief conducts roll call of the Operation Section Supervisors and provides a briefing on emergency response.		
<input type="checkbox"/> Operations Section Chief briefs supervisory personnel on their assignments along with clarification on any of their issues and concerns.		
<input type="checkbox"/> Safety Officer covers major safety issues.		
<input type="checkbox"/> Logistics Section Chief covers logistical support of operations (communications, supply, transportation, medical, etc).		
<input type="checkbox"/> Finance / Admin. Section Chief covers time & cost tracking, procurement, and compensation process.		
<input type="checkbox"/> General Staff to cover issues applicable to Operations Section personnel.		
<b>Key Points:</b>		
<ul style="list-style-type: none"> <li>• <b>Ensure that the meeting is documented / recorded.</b> (Utilize the back side of this page.)</li> <li>• Planning Section Chief opens briefing, covers ground rules, agenda, and conducts roll call of Command and General Staff members.</li> <li>• Establish a briefing and message for all responders.</li> <li>• Review pre-determined public and media statements.</li> <li>• Planning Section Chief solicits final comments and adjourns briefing.</li> </ul>		

Notes:

# Section 3: Communication & Media

Guiding Principles and Approach.....1

Media Communications.....2

Preliminary Media Statement.....3

This page is intentionally left blank

---

## Guiding Principles and Approach

Ovintiv will be responsible, understanding and compassionate to the needs of stakeholders directly impacted by the crisis, but place the following priority on communications that support the safety of:

- people (i.e. landowners, community residents and staff)
- the environment
- property/business

Stakeholders impacted by a crisis should be notified in a timely manner about potential risks so they can make informed decisions about potential personal implications

### Communications Response by Severity

Ovintiv's system for assessing incident severity is outlined in the Emergency Preparedness Standard of Ovintiv's environment, health and safety (EH&S) management system, Ethos. This system aligns with the system used by the BC Energy Regulator (BCER).

The following chart outlines the four severity levels and the suggested corresponding communications response. In the event that reputational impacts/risks warrant an elevated communications response, consider revising and escalating the communications response.

Severity	Communications Response/Strategy
<b>Alert</b>	Communications may heighten media and social media monitoring to include keyword searches relevant to the situation. Key messages and/or standby statements will be reviewed and updated. Communications may not be immediately aware of an Alert-level incident.
<b>Level 1</b>	Communications will heighten media and social media monitoring and be prepared to respond to inquiries from the public, concerned community stakeholders and social and conventional media. Key messages and a holding statement will be developed if required and distributed as necessary.
<b>Level 2</b>	Ovintiv will proactively engage with impacted stakeholders and local and/or regional media if interest or awareness is evident. Any decision to issue a news release or hold a news conference for a Level Two incident will be made in consultation with the senior management team (or under the direction of the appropriate regulator). Mainstream and social media is regularly monitored.
<b>Level 3</b>	Ovintiv will proactively communicate with all stakeholders (both internal and external) and all local, provincial, national or international media as appropriate. Ovintiv may actively distribute information to the media over the wire and may consider holding formal press conferences. Mainstream and social media is constantly monitored (regulatory requirements vary).

## Media Communications

**Note: Media updates must be generated and released as significant developments occur. Ovintiv will coordinate media releases whenever possible with the regulator prior to publication to ensure consistency and accuracy of information.**

Under most regulatory jurisdictions, the following information must be released to the general public as soon as possible during an incident:

- type and status of incident,
- location and proximity of the incident to people in the vicinity,
- areas impacted by the incident,
- effects the incident may have on people in the vicinity,
- actions the general public should take if they experience adverse effects,
- description of the products involved and their short- and long-term effects,
- public protection measures to follow, evacuation direction, and any other emergency response measures to consider,
- actions being taken to correct the situation and time period anticipated, and
- contacts for additional information.

The effectiveness of Ovintiv's media relations during an emergency depends on the co-operation and mutual support of three components:

- Only the field-based Incident Commander and the Media Spokesperson are authorized to release information to the media;
- The Incident Commander and the Media Spokesperson should confirm facts prior to either spokesperson releasing information; and
- Ovintiv personnel should co-operate with reporters by referring them to the Incident Commander or the Media Spokesperson.
- Do not wait until you are contacted by the media to react to their inquiries. By preparing in advance, the company will appear to be organized, aware, and actively responding to the situation. The essence of effective media management is preparation in advance of any media contact.
- It is important when contacting the media with a news release that you do not favour one media organization or agency over another. To minimize the chances of creating a prejudicial situation, deal solely with major umbrella press agencies.
- If media representatives are not provided with the basic information, it can be assumed that they will fill the gap with material from less reliable sources.

Be aware at all times that it is possible for the media or others to be monitoring your radio, cellular phone, or telephone conversations.

## **Preliminary Media Statement**

Date: \_\_\_\_\_

Time: \_\_\_\_\_

We can confirm an incident occurred at Ovintiv's [insert facility/site]. Our team in the field is actively responding and we are gathering more information about the nature and severity of the incident. An Ovintiv spokesperson will provide more information when it is available.

You can contact our media spokesperson at (281) 210-5253.

This page is intentionally left blank

# Section 4: Emergency Response Procedures

<b>Public Protection Measures</b> .....	<b>1</b>
Public Protection Measures Flowchart .....	1
Evacuation .....	2
Shelter-in-Place .....	3
Establishing and Isolating a Perimeter .....	11
Ignition .....	12
H <sub>2</sub> S / HVP Ignition Procedure .....	13
Road and Airspace Closures .....	15
Air Monitoring .....	15
<b>Spill Response, Containment and Recovery</b> .....	<b>1</b>
<b>Spill Response</b> .....	<b>1</b>
Spill Response Objectives and Strategies .....	1
Control Points .....	2
Health and Safety .....	4
Initial Site Assessment .....	4
Safety Briefing .....	4
Initial Site Safety and Hazard Control Plan .....	4
Western Canadian Spill Services (WCSS).....	5
Provincial Petroleum Release Reporting Requirements Chart .....	7
<b>Containment and Recovery</b> .....	<b>9</b>
Understanding Environments – Ground and Water .....	9
Containment of Spilled Product.....	11
Containment to Recovery Process for Moving Water .....	15
Recovery of Spilled Product .....	16
Recovery Techniques.....	17
Spill Control Tactics (Sorbents, Berms, Trench and Bell Hole, Aquadam, Culvert Block, Boom Deployment, and Skimmers / Temporary Storage / Vacuum Units)	
<b>Post-Incident</b> .....	<b>1</b>
Call Down Notification .....	1
Public Care and Assistance.....	1
Clean-up and Repair .....	2
Third Party Investigations .....	2
Review and Debriefing .....	3
Critical Incident Stress Debriefing (CISD) .....	3
Post-Incident / Accident Investigation.....	4
<b>Medical Emergencies</b> .....	<b>1</b>
First Aid Information .....	2
Next-of-Kin Notification.....	5
Medical Evacuation (MEDEVAC) Procedure .....	7

---

<b>Responder Safety</b> .....	<b>1</b>
Site Safety .....	1
On-Site Work Areas .....	2
Working Alone .....	4
Missing Persons .....	6
Rest Periods .....	6
<b>Fire / Explosion</b> .....	<b>1</b>
Classification of Fires .....	3
Response Actions Based on Type of Fire .....	4
Wildfire Response .....	9
<b>Transportation Incidents</b> .....	<b>1</b>
First On-Scene Transportation (Road, Rail, Marine) Incident Flowchart .....	1
Loss, Theft or Unlawful Interference Reporting Flowchart .....	2
Motor Vehicle Accidents .....	3
Emergency Response Assistance Canada (ERAC) Plan .....	4
CANUTEC – Canadian Transport Emergency Centre .....	4
Dangerous Goods References .....	5
TDG Reportable Quantities .....	5
Rail Car Identification Chart .....	7
Road Trailer Identification Chart .....	9
Table of Markings, Labels and Placards .....	11
TDG 30 Day Follow-up Report Form .....	13
<b>Weather and Natural Disasters</b> .....	<b>1</b>
Earthquake .....	2
Floods .....	4
Thunderstorm and Lightning Safety .....	6
Tornados .....	7
Winter Storms: Blizzards, Freezing Rain, Heavy Snow, Blowing Snow .....	7
After a Disaster .....	9
<b>Security Incidents</b> .....	<b>1</b>
Responding to threats .....	1
Bomb threats .....	2
Suspicious packages .....	5
Trespassing .....	7
Vandalism .....	8
Terrorism .....	8
Cyber-Attacks .....	9
<b>Animal Encounters</b> .....	<b>1</b>
First Responders to Animal attacks .....	1
Bears .....	1
Cougars .....	4
Large Hooved Animals (Ungulates) .....	6
Rattle Snakes .....	7
Wolves .....	8
Bees and Wasps .....	9
EpiPens .....	10

---

## Public Protection Measures Flowchart

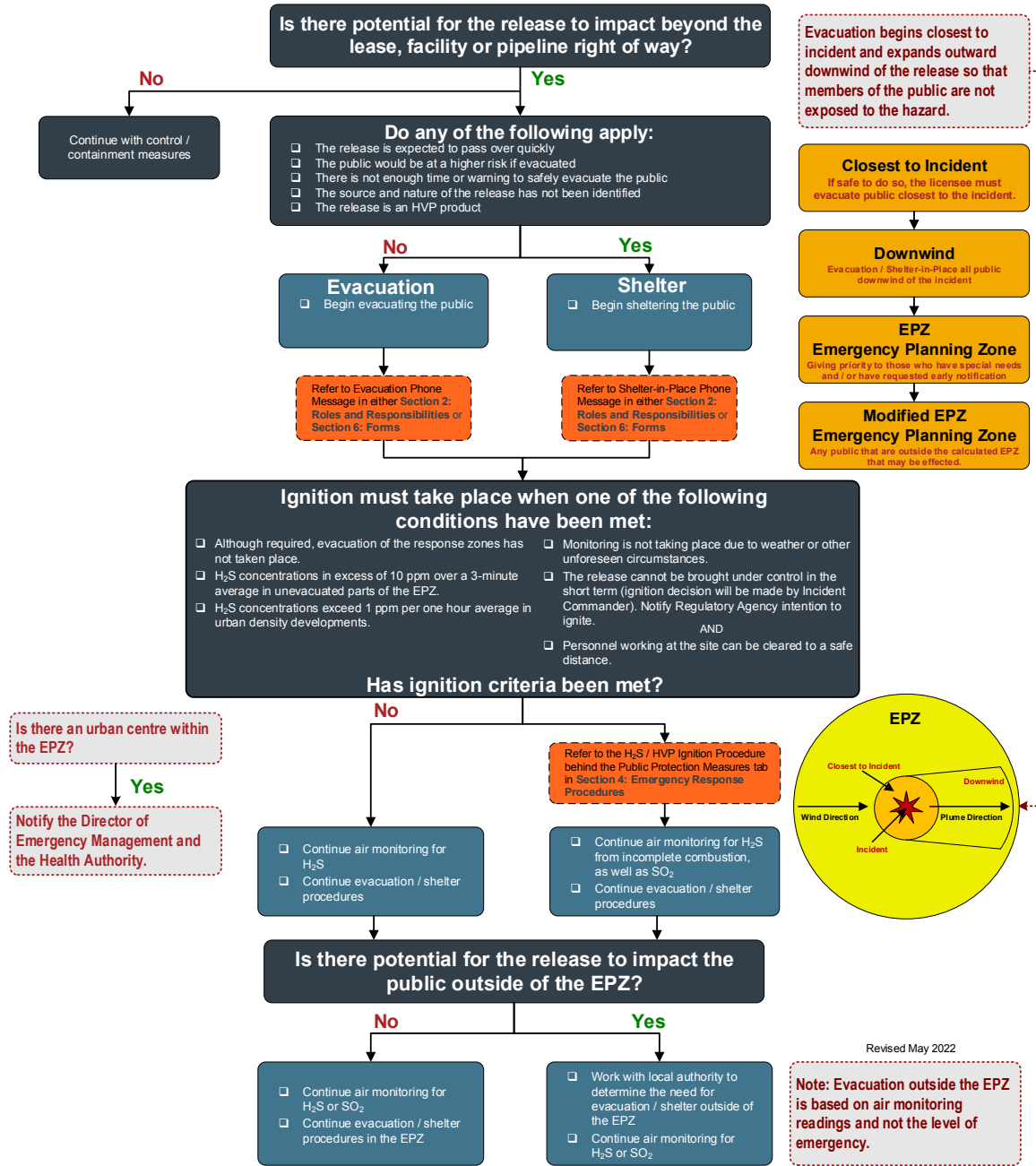

### Notification and Evacuation Requirements Outside of the EPZ

For a sour gas release, the licensee must continuously assess and act on the need to expand the evacuation area based on the monitored levels of H<sub>2</sub>S and SO<sub>2</sub>. In the absence of monitored readings, responders should advise the residents to Shelter-in-Place.

H <sub>2</sub> S Requirements		SO <sub>2</sub> Requirements	
1-10 ppm	Individuals who requested notification so that they can voluntarily evacuate before any exposure to H <sub>2</sub> S or SO <sub>2</sub> must be notified.	1-5 ppm	Individuals who requested notification so that they can voluntarily evacuate before any exposure to H <sub>2</sub> S or SO <sub>2</sub> must be notified.
10 ppm and above (1-hour average)	Local conditions must be assessed and all persons must be advised to evacuate and/or shelter.	5 ppm and above	Local conditions must be assessed and all persons must be advised to evacuate and/or shelter.
<p><i>Note: H<sub>2</sub>S Evacuation Level – when downwind monitoring at the nearest unevacuated residence, outside the Hazard Planning Zone, indicates a level of 10 ppm, evacuation procedures will be initiated if safe to do so.</i></p>			

## Public Protection Measures, continued

There are three primary public protection measures that are used to ensure the safety of the public in the event of an incident: shelter-in-place, evacuation, and ignition.

All members of the public within the EPZ will be given the *Shelter-In-Place or Urgent Evacuation* message depending on the best public safety action for the circumstances. Ovintiv's Incident Commander and Public Protection Chief will make this determination.

### Evacuation

For long-term releases, evacuation is preferred to sheltering if public safety can be assured during the evacuation process.

Evacuation is a viable public protection measure in circumstances when:

- The location of the plume is known, and safe egress routes can be assured
- The release will not likely be contained in the near future
- Visibility and road conditions are good
- The residents clearly understand their directions

**Tactical Evacuation:** A measure to immediately move people to a safe area as part of emergency response and operations. Does not require approval from local authority but the local authority may enact an evacuation order, if required. The local authority must be advised if a tactical evacuation has occurred. Appropriate methods must be utilized to ensure transients (hunters, trappers, recreational users, non-resident landowners, etc.) within the EPZ are located and evacuated. **Refer to pages 7 to 10 or Section 6: Forms for Evacuation Scripts** for information that should be communicated as part of the evacuation process.

**Planned Evacuation:** An evacuation coordinated by local government authority that can authorize evacuation alerts and orders.

Residents should also be evacuated during ongoing emergency flaring or burning if their health and safety could be affected by the operation.

Special procedures may be required for evacuating large industrial operations and/or public facilities. If large numbers of people are involved, the licensee must address assistance with transportation. Refer to the Area Specific Information Section for information regarding transportation (e.g., providing school buses) or other changes in the normal notification procedures.

The licensee must continuously assess and act on the need to expand the evacuation area, based on the specifics of the incident, including harmful levels of hazardous substances.

The licensee is expected to monitor the air quality along the edge of the EPZ to determine if sheltering or evacuation criteria have been met outside the EPZ. Evacuation outside of the EPZ must be coordinated with the Local Authority.

Appropriate methods must be utilized to ensure transients (hunters, trappers, recreational users, non-resident landowners, etc.) within the EPZ are located and evacuated. When a tactical evacuation has taken place, the appropriate local authority must be notified.

### Outside the Emergency Planning Zone

Ovintiv is prepared to protect the safety of all area users by evacuation, shelter-in-place or possibly ignition of the release. Ovintiv's Emergency Response Team will coordinate their public safety actions with the Local Authority for any affected area beyond the EPZ.

In BC, the Municipality/Local Authority and/or EMCR is responsible for residents outside of the EPZ.

## Public Protection Measures, continued

### Evacuation, continued

#### Notification and Evacuation Requirement for Areas outside the Emergency Planning Zone

##### Hydrogen Sulfide Gas (H<sub>2</sub>S)

*In BC:*

1 – 9 ppm

Individuals must be informed of the concentrations and advised to leave. All other individuals should consider leaving the area and seek medical advice if health symptoms develop.

Exceeds 10 ppm

Immediate evacuation of the area must take place or the release must be ignited.

##### Sulphur Dioxide Gas (SO<sub>2</sub>)

*In BC:*

1 ppm

Voluntary evacuation

2 ppm

Evacuation of the area should begin

5 ppm

Mandatory evacuation of the area

**Note:** The Sulphur Dioxide SO<sub>2</sub> gas levels are a guide only. Should a person experience increasing difficulty due to the presence of Sulphur Dioxide gas, that person should be advised to leave the area and consult a physician.

##### Natural Gas Liquids (NGL)

If there is **any** detectable level of combustible gas that poses a threat of toxicity, explosion, or fire in an unevacuated area.

## Shelter-In-Place

Shelter-in-place is considered the primary safety measure when the hazard is of a limited duration or the public would be at a higher risk if evacuated. Sheltering within a building creates an indoor buffer to protect affected individuals from higher (more toxic) concentrations that may exist outdoors. The goal is to reduce the movement of air into and out of the building until either the hazard has passed, or other appropriate emergency actions can be taken (such as evacuation).

Sheltering indoors is a viable public protection measure in circumstances when:

- There is insufficient time or warning to safely evacuate the public
- Residents are waiting for evacuation assistance
- The release will be of a limited size and /or duration
- The location of the release has not been identified
- The public would be at a higher risk if evacuated
- Escape routes traverse the hazards

Refer to either **Page 5** or **Section 6: Forms** for the Shelter-in-Place Phone Message script to be used when contacting residents. Residents advised to shelter-in-place will be notified if additional measures are required, and when it is “all-clear”.

---

## Public Protection Measures, continued

### Sheltering Measures for HVP Product Release

For a flammable or combustible liquid fire to start, a mixture of vapour and air must be ignited. There are many possible ignition sources:

- Sparks from electrical tools and equipment
- Sparks, arcs, and hot metal surfaces from welding and cutting
- Tobacco smoking
- Open flames from portable torches and heating units, boilers, pilot lights, ovens, and driers
- Hot surfaces such as boilers, furnaces, steam pipes, electric lamps, hot plates, irons, hot ducts and flues, electric coils, and hot bearings
- Embers and sparks from incinerators, foundry cupolas, fireboxes, and furnaces
- Sparks from grinding and crushing operations
- Sparks caused by static electricity from rotating belts, mixing operations or improper transfer of flammable or hot combustible liquids

You can eliminate many ignition sources by:

- Removing open flames and spark-producing equipment
- Not smoking around these liquids
- Using approved explosion proof equipment in hazardous areas

**LEVEL 1, 2 or 3 EMERGENCY MESSAGE - STAY IN SHELTER**

If you reach a voice mail message, please read the following script:

“This is \_\_\_\_\_ [your name] of Ovintiv calling from the \_\_\_\_\_ [facility/office name] at \_\_\_\_\_ [time, date] with an important message for \_\_\_\_\_ [resident name].

Please contact me at \_\_\_\_\_ [number] when you receive this message.”

Hello, is this the \_\_\_\_\_ residence at \_\_\_\_\_ ?  
(name) (phone number)

This is \_\_\_\_\_ (your name) calling from Ovintiv with an important safety message.  
Please listen carefully.

We are responding to a serious problem in the area. All efforts are being made to solve the problem.

**For your safety** it is essential that you gather everyone in the house, close all windows and doors and remain sheltered indoors.

How many people are in your house right now? \_\_\_\_\_  
Is there anyone outside who you **cannot** easily contact? \_\_\_\_\_ (Yes / No)

**If YES:** Determine the location of anyone outside and assure the resident that you will send someone to find them as soon as possible.

**Please:**

- Close (and keep closed) all your windows and doors.
- If possible shut off any exhaust fans, such as:
  - stove fans, bathroom vents, clothes dryer, air conditioner or built-in vacuum systems
- Extinguish the fire in your fire place.
- Go to the interior of your house away from any windows or doors.
- Do not leave your house.
- Avoid using your telephone so that we can contact you again with additional information.

Do you understand these instructions? \_\_\_\_\_ (Yes / No)

I will call you back with an update within an hour. In the meantime, if you have urgent questions, you can call me.

Again, my name is \_\_\_\_\_ and my number is \_\_\_\_\_.  
(name) (phone number)

This page is intentionally left blank

**LEVEL 1 EMERGENCY MESSAGE - NOTIFICATION/VOLUNTARY EVACUATION**

If you reach a voice mail message, please read the following script:

“This is \_\_\_\_\_ [your name] of Ovintiv calling from the \_\_\_\_\_ [facility/office name] at \_\_\_\_\_ [time, date] with an important message for \_\_\_\_\_ [resident name].

Please contact me at \_\_\_\_\_ [number] when you receive this message.”

Hello, is this the \_\_\_\_\_ residence at \_\_\_\_\_ ?  
(name) (phone number)

This is \_\_\_\_\_ (your name) calling from Ovintiv with an important safety message.  
Please listen carefully.

**We are currently experiencing operational difficulties in the area. At this time, there is no danger to your health or safety. Remedial operations are underway.**

As a precaution, you and your family have the option of evacuating your residence at this time.

Do you wish to evacuate at this time? \_\_\_\_\_ (Yes / No)

**IF YES:** If you wish to evacuate at this time, go to our evacuation Reception Centre located at the \_\_\_\_\_ (hall, centre, office, hotel).

An Ovintiv representative will greet you there and address your questions.

- How many persons are at your residence right now? \_\_\_\_\_ .
- Do you have transportation? \_\_\_\_\_ (Yes / No)
- Will you require assistance? \_\_\_\_\_ (Yes / No)

*If assistance is need, advise them to close their windows and doors and remain indoors. Assure them that you will send someone to pick them up.*

**Action this immediately.**

**IF NO:** How can we reach you to keep you updated? \_\_\_\_\_

Please let us know if you decide to leave the area.

Do you understand these instructions? \_\_\_\_\_ (Yes / No)

Again, my name is \_\_\_\_\_ and my number is \_\_\_\_\_.  
(name) (phone number)

This page is intentionally left blank

**LEVEL 2 or 3 EMERGENCY MESSAGE - URGENT EVACUATION**

If you reach a voice mail message, please read the following script:

“This is \_\_\_\_\_ [your name] of Ovintiv calling from the \_\_\_\_\_ [facility/office name] at \_\_\_\_\_ [time, date] with an important message for \_\_\_\_\_ [resident name].

Please contact me at \_\_\_\_\_ [number] when you receive this message.”

Hello, is this the \_\_\_\_\_ residence at \_\_\_\_\_?  
(name) (phone number)

This is \_\_\_\_\_ (your name) calling from Ovintiv with an important safety message.  
Please listen carefully.

We are responding to an emergency in the area.

**For your safety**, you must leave immediately and go to our evacuation Reception Centre located at the \_\_\_\_\_ (hall, centre, office, hotel). An Ovintiv representative will greet you there and address your questions.

Is there anyone outside who you **cannot** easily contact? \_\_\_\_\_ (Yes / No)

**If YES:** Determine the location of anyone outside and assure the resident that you will send someone to find them as soon as possible.  
**Action this immediately by notifying your Supervisor.**

Do you have your own transportation? \_\_\_\_\_ (Yes / No)

**If NO:** Advise them to close their windows and doors and remain indoors.  
Assure them that you will send someone to pick them up.  
**Action this immediately.**

Do you understand these instructions? \_\_\_\_\_ (Yes / No)

Are you leaving immediately? \_\_\_\_\_ (Yes / No)

Again, my name is \_\_\_\_\_ and my number is \_\_\_\_\_.  
(name) (phone number)

Thank you for your cooperation.

This page is intentionally left blank

# Public Protection Measures, continued

## Establishing and Isolating a Perimeter

### 1. Identify the location of the incident on the map:

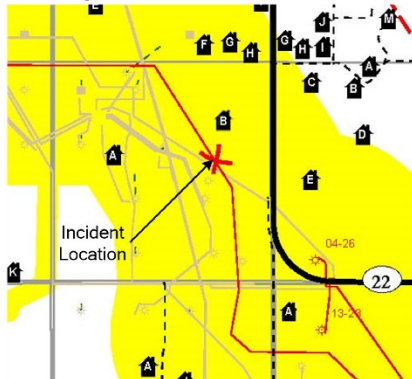

### 2. Determine the size of response zones (hazard areas):

EPZ - Emergency Planning Zone  
 Closest to Incident  
 Downwind

You can find this information:

- a) Labeled on the map
- b) In the site specific tables
- c) As the yellow area on the map

If the incident is at a facility or if you have not yet confirmed the exact location of the incident, you must use the largest EPZ for the area. The largest EPZ for the area is shown in yellow on the map.

### 3. Determine the wind direction

Look for wind direction indications such as flags, windsocks, direction of smoke, etc..

Draw the wind direction on the map with an arrow.



### 4. Draw the zones on map:

- a) EPZ - The entire hazard area
- b) Those closest to the hazard

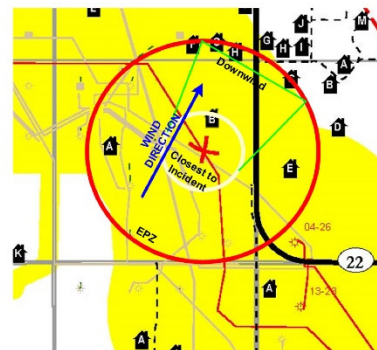

### 5. Isolate the hazard area with roadblocks

If any residences exist between the optimal roadblock location and the EPZ, expand the EPZ to include those residences.

Additionally, if any residences only route of egress is through the EPZ, expand the EPZ to include those

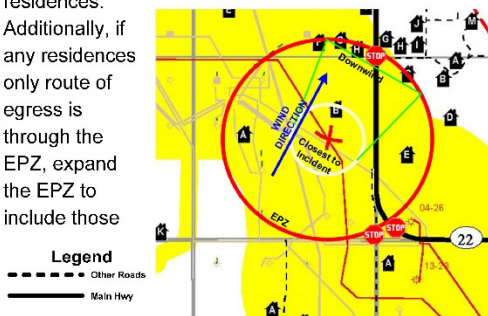

### 6. Following the appropriate provincial public protection measures chart, initiate public safety activities.

Residents closest to the hazard are the most at risk of being adversely affected.

Residents downwind of the EPZ are the second group to be evacuated / sheltered in place as being downwind of the hazard puts them at a higher risk than the rest of the residences in the EPZ that are upwind or crosswind from the hazard.

## Public Protection Measures, continued

### Ignition

In conjunction with shelter-in-place and evacuation strategies, the release may be ignited at the source in order to reduce public exposure to the hazard. The combustion of the hydrogen sulphide (H<sub>2</sub>S) results in the produced sulphur dioxide (SO<sub>2</sub>) being carried high into the atmosphere allowing additional time for the public to safely evacuate. If an immediate threat to human life exists and there is not sufficient time to evacuate the hazard area or the Emergency Planning Zone (EPZ) – whichever is bigger – the On-Site Group Supervisor is authorized to ignite the release.

*Note: Only those personnel trained in ignition procedures can determine if ignition is required and operate the ignition equipment.*

Ignition of an HVP product release should occur only after the position of the plume has been established, after careful deliberation, and when safe to do so.

Until such time that a decision has been made to ignite a release, the licensee should take steps to minimize any chance of unplanned ignition in the area.

*Note: Initial location of the plume may be identified by the following methods:*

- *Visually (i.e.; frost or condensation buildup, white cloud or dust cloud, dead vegetation, bubbling water, etc.)*
- *Auditory (i.e.; hissing or whistling sound, etc.)*
- *Smell (i.e.; smell of mercaptan – rotten eggs)*

When making the decision to ignite, the licensee must take the following into consideration:

- If personnel are on-site, proceed to muster location for headcount and further instructions. Refer to Five Step Initial Response Guide in **Section 1: Initial Response** for First On-Scene Actions.
- Refer to the H<sub>2</sub>S / HVP Ignition Procedure on the following page for further considerations.

If at all possible, the On-Site Group Supervisor must consult with higher authority individuals within the company (ideally the Operations Section Chief, Incident Commander, EOC Director, etc.) and the appropriate government regulator.

**Pre-Ignition Considerations – On-Site Group Supervisor**

When making the decision to ignite, the licensee must take the following into consideration:

**Hydrogen Sulphide (H<sub>2</sub>S)**

- Risk of exposure / injury to the public or response workers.
- Proximity to residences, public facilities, towns or urban centres.
- Availability of air monitoring equipment and personnel.
- Availability of ignition equipment, and training of staff in its use.
- Detectable concentration of H<sub>2</sub>S and/or flammable gases near the source of the release and within the EPZ.
- Status of evacuation.
- Duration of the release and potential volume.
- Wind/Weather conditions and general topography.
- Impacts to livestock and other values at risk including property, timer or infrastructure.
- Fire hazard after ignition in relation to adjacent forested or cropland area.
- Safety of the Ignition Team (hazard area identification, protective gear).

**High Vapour Pressure (HVP)**

- Increased risk(s) of delayed ignition.
- If the perimeter of the hazard area has been established.
- If the public has been evacuated from the area.
- If ignition will worsen the situation by endangering the public or the environment or damaging the equipment used to control the product.
- If wind direction has been established and is being continually monitored.
- If the possibility of an explosion has been assessed (i.e., obstructions or regions of congestion within the perimeter of the dispersion vapour cloud).

**Ignition must take place when one of the following conditions has been met:**

- Although required, evacuation of the response zones has not taken place.
- Monitoring results indicate H<sub>2</sub>S concentrations in excess of 10 ppm over a 3-minute average in unevacuated parts of the EPZ.
- H<sub>2</sub>S concentrations exceed 1 ppm per one hour average in urban density developments.
- Monitoring is not taking place due to weather or other unforeseen circumstances
- The release cannot be brought under control in the short term (ignition decision will be made by Incident Commander. Notify Regulatory Agency intention to ignite. AND Personnel working at the site can be cleared to a safe distance.

If monitoring levels are declining, then the situation needs to be continuously assessed for ignition. Once any of the above conditions have been met, ignition must occur within 15 minutes of the decision to ignite.

**Is There time to discuss the ignition decision with the Operations Section Chief, the Incident Commander, and the Regulatory Agency?**

**Yes**

**No**

- Review with the Operations Section Chief, the Incident Commander, and Regulatory Agency:**
- Employee and public safety.
  - Site conditions.
  - Site control procedures.
  - Monitoring of Emergency Hazard Area.

**Is ignition the most favourable control option to minimize the hazard?**

**No**

**Yes**

- Continue with release control procedures onsite.
- Review possible control procedures.

- Determine post ignition emergency service requirements.
- Assemble and brief ignition team.
- Go to Ignition Procedures Flowchart.

**Ignition Procedure – On-Site Group Supervisor**

**Preplanning**

Prior to ignition the Operations Section Chief will:

- Ensure all nonessential personnel are evacuated.
- Isolate the hazard area using manned roadblocks.
- Assemble the Ignition Team (2 people).
- Ensure the Ignition Team is protected with personal protective equipment, clothing and breathing apparatus (cover exposed skin).
- Erect windsock and streamers (if time permits).
- Monitor the area for combustible gas.
- Fully discuss ignition procedures.
- Check radio communications.

**Approach**

Select a position to attempt safe ignition which will:

- Allow for safe retreat.
- Be upwind of the gas leak (300m minimum from edge of identified vapor plume, approach no closer than 100m on repeated ignition attempts).
- Be in an area where no combustible gas is detected.
- If possible, get behind a hill, building, tree or other protective barrier to shield yourself.

**Attempt Ignition**

- Fire flare gun to hit vapour cloud at the perimeter where air to fuel mixtures are correct for ignition (near outer edge and ground level).
- Turn away from target.

**Plume Ignited?**

**No**

**Yes**

**Example Ignition Kit**

- 2 Flare Pistol
- 36 Flares
- 2 Safety harness with front D-ring
- 2 30m (100ft) flame resistant rope
- 2 Flame resistant coveralls
- 2 Sets of ear protection
- 2 Hard hats with face shield
- 2 Flame resistant hard hat liners (balaclava or regular style)
- 1 LEL Gas detector
- 1 H<sub>2</sub>S Gas detector
- 4 Self contained breathing apparatus (positive pressure) with 30 minute air supply, includes 2 spare bottles
- 1 Radio equipped vehicle

**Repeat Ignition**

- Continue approach and repeat until successful (100m minimum from edge of identified vapour plume).
- DO NOT proceed if Ignition Team is no longer in a safe area.

**Post Ignition**

- Advise Incident Commander.
- Continue to monitor downwind for gas accumulations from incomplete combustion as well as SO<sub>2</sub>.
- Maintain security around immediate area.
- Assist emergency service crews with any fire control measures needed.

Revised November 2021

This page is intentionally left blank

## Public Protection Measures, continued

### Road and Airspace Closures

The company should receive authorization from local authorities or the RCMP before establishing roadblocks on public roads. The company must contact the RCMP and the Ministry of Transportation to have one, two or three-digit highways closed. However, if the safety of the public is in jeopardy, the company must be prepared to quickly restrict access to the area before contacting these agencies.

If warranted, the regulatory agency can issue a Closure Order that provides legal authority to close the area. The local authority may, if warranted, declare a Local State of Emergency. This grants the local authority special powers to do such things as road closures or declare mandatory evacuation.

The public must also be prevented from flying into the airspace above a gas release. It may be necessary to issue a Notice to Airmen (NOTAM) to advise pilots of restrictions in the airspace above the EPZ or to close the airspace for a certain radius from the release (a no-fly zone). NOTAMs are issued by NAV Canada and airspace closures are issued by Transport Canada's Aviation Operations Centre (AVOPS). NOTAMs or airspace closures may be requested by the licensee at a level 2 or level 3 emergency.

### Air Monitoring

Air monitoring equipment is used to:

- Track/follow the plume.
- Determine if ignition criteria are met.
- Determine whether evacuation and / or shelter-in-place criteria have been met.
- Determine roadblock locations.
- Determine concentrations in areas being evacuated to ensure that evacuation is safe.
- Assist in determining when the emergency can be downgraded.

As such, H<sub>2</sub>S, SO<sub>2</sub>, LEL or other toxic substance concentrations will be monitored continuously during the incident response and it is crucial that Air Monitors continuously update their direct supervisor with monitored results.

- Air monitors (personal handheld, stationary and mobile) should be dispatched at a Level 1 Emergency.
- Air quality monitoring occurs downwind, with priority being directed to the nearest un-evacuated residence or area where people may be present.
- Licensee personnel will monitor and record the concentrations until a mobile air monitoring unit arrives or until the incident is over. At minimum, these readings must include LEL and H<sub>2</sub>S.
- Mobile air quality monitoring units must be dispatched when it is evident that spill control measures are not effective and that a sour product release is likely to occur.
- For HVP releases, monitoring may occur downwind or upwind, depending on how the plume is tracking, with priority being directed to the nearest un-evacuated residence or areas where people may be present. The licensee is expected to provide monitored HVP product LEL information on a regular basis for the duration of the incident.
- If a sour gas release has been ignited, the licensee should continue to monitor response zones for H<sub>2</sub>S from incomplete combustion, as well as SO<sub>2</sub>.
- Ensure all equipment is operational and the appropriate documentation is available to verify testing and calibration requirements.

This page is intentionally left blank

## Spill Response

The spill response section can be used as a quick reference by first-on-scene responders to select and implement containment and recovery tactics with spill response equipment during the first 48-72 hours of the response. This section contains a collection of inland spill tactics that can be applied using obtainable resources to a liquid product release until additional resources and personnel arrive on site. This section is a reference tool and supplement to prior training, field experience, technical instruction, and equipment operation knowledge. The licensee will rely on the training and judgment of its first-on-scene responders to select only those tactics that can be accomplished safely.

Refer to the Petroleum Industry Release Reporting Requirements chart at the end of this section to determine the TDG and Provincial Reporting Requirements for each class of chemicals (as classified by the TDG Hazard Classification System).

### Spill Response Objectives and Strategies

Objectives establish the desired outcomes of an incident and are statements of intent related directly to response priorities. Priorities are situational and influenced by many factors, with life safety always being the highest priority followed by incident stabilization and property and environment. The Incident Commander comes to a consensus on a collective set of objectives with response strategies. The following table contains some standard objectives with example strategies that can be utilized to assist in the first four to six hours of a spill response.

Objectives	Strategies
Ensure the safety of citizens and response personnel	Identify hazard(s) of spilled material.
	Establish work zones (hot, warm, and cold zones).
	Establish site perimeter and access controls.
	Consider evacuation or shelter-in-place, as needed.
	Monitor air quality in impacted areas to ensure responders select appropriate Personal Protective Equipment (PPE).
	Establish aircraft restrictions.
	Develop a Health and Safety Plan for response personnel.
	Run air dispersion model to determine potential evacuation zones.
Control the source of the spill	Complete emergency shut-down procedures.
	Eliminate potential flammable vapour ignition sources.
	Initiate temporary repairs to stop the leak.
	Transfer product to an approved container or facility.
	Construct barriers to prevent spill from reaching a waterbody.
Maximize protection of environmentally sensitive areas	Implement Control Points and pre-designated response strategies.
	Identify and prioritize the environmentally sensitive areas.
	Identify Resources at Risk (RAR) in spill vicinity.
	Track oil movement and develop spill trajectories.
	Conduct visual assessments (e.g., aerial overflights, ground-truthing).
	Identify, prioritize, and flag areas used as habitat by endangered species.
	Develop/implement appropriate protection strategies.

## Spill Response, continued

Objectives	Strategies
Manage a coordinated response effort	Complete or confirm notifications.
	Establish Incident Command Post.
	Ensure local government and Indigenous officials are included in response organization.
	Initiate spill response Incident Action Plan.
	Ensure mobilization and tracking of response resources.
	Account for personnel and equipment
	Maintain, complete, and log all documentation related to the incident.
	Evaluate planned response objectives vs. actual response.
Contain and recover spilled material	Deploy containment boom at the spill source.
	Deploy containment boom at appropriate recovery areas.
	Conduct open water skimming.
	Develop disposal plan.
Recover and rehabilitate injured wildlife	Establish oiled wildlife reporting hotline.
	Conduct injured wildlife search and rescue operations.
	Operate wildlife rehabilitation center.
	Establish team for injured wildlife.
Remove oil from impacted areas	Conduct appropriate shoreline cleanup efforts.
	Clean oiled structures.
	Clean oiled equipment.
Keep stakeholders informed of response activities	Provide forum to obtain stakeholder input and concerns.
	Provide stakeholders with details of response actions.
	Identify stakeholder concerns and issues and address as practical.
	Provide regulatory bodies details of response actions.
Keep the public informed of response activities	Provide timely safety announcements.
	Conduct public meeting, as appropriate.
	Conduct regular news briefings.
	Manage news media access to spill response activities.

## Control Points

The objective of control points is to identify pre-planned locations where spill responders can safely and effectively deploy oil spill response equipment to intercept and limit downstream movement of oil on a watercourse. Depending on the specific conditions at the time of a spill, one or more control points may be implemented as part of a response. Control points are intended to:

1. Protect sensitive areas downstream.
2. Provide locations for oil removal and collection.

## Spill Response, continued

Typically, oil spill response entails multiple parallel and simultaneous activities including:

1. Source control (valve closures, clamping and pipeline drain-down)
2. Near source response (containment using berms and recovery using pumping and skimming)  
Downstream response (control points)

Control points are pre-identified points along watercourse's and lakes that provide responders with key tactical information and can greatly reduce planning and implementation of containment, recovery, public protection, and wildlife protection measures during a response to a spill. Control points are typically grouped in the following categories:

1. Critical Control Points are established based on the company's asset locations and are based on the following criteria:
  - a. River crossing with easy access and staging areas.
  - b. Upstream of environmentally sensitive areas.
  - c. Upstream or proximity to communities and public infrastructure such as drinking water intakes.
  - d. Downstream of major infrastructure such as pipelines, storage, or facilities.
  - e. In areas of high-volume transportation corridors.
2. Non-Critical Control Points may include the following:
  - a. Recreational areas
  - b. Private or public land
  - c. Boat launches

When assessing the location of a control point the following factors should be considered:

1. Sites should be located downstream of the watercourse crossing and at distances that can be reached in a two- to four-hour-response time.
2. Sites should have reasonable land access.
3. Sites should have available working space for staging equipment and personnel.
4. Ideally, river flow should be slow or pooled, and/or with back eddies rather than turbulent flow conditions.
5. Ideally, sites should have public access, low banks, and should not be heavily vegetated.

Designated site-specific control points need to be reviewed at least annually. Each control point site should be visited periodically to evaluate suitability and to ensure information is accurate and complete. Old unsuitable control points should be removed, and new control points added, as a part of revisions to site specific information, as required. Control point listings should include a site description, site diagram, access description, landowner/occupant phone number, site suitability and any other information related to the site.

For a detailed list of control points, utilize the Western Canadian Spill Services (WCSS) website (<http://www.wcss.ab.ca>)

---

## Spill Response, continued

### Health and Safety

Committed to the protection of the health and safety of all spill response personnel and third parties whether members of the public or contractor personnel. The Site Safety Plan is intended to protect all personnel against potential health and safety hazards by providing information in identifying, evaluating, controlling risks, and explaining procedures to be followed during emergencies.

Provisions have been made to ensure that the health and safety of third parties, particularly members of the general public, is also protected. Third party protection procedures include evacuations, the monitoring of wind direction at the site of the release to determine the direction and spread of hazardous vapours and, if considered appropriate, conducting air monitoring in other areas where responders or third parties could be threatened.

### Initial Site Assessment

The initial site assessment, hazard identification, and characterization will normally be performed by a minimum of two qualified persons outfitted in appropriate personal protective equipment. Where possible, a backup team should be immediately available. The information gained during the initial site assessment will be used to determine the site work zones (hot, warm, and cold zones) and in the development of the Site Safety Plan. The Site Safety Plan must be monitored on an ongoing basis and revised to reflect changing conditions. Personnel entering or already on site must be immediately advised of changes. The person responsible for the Site Safety Plan will ensure compliance is monitored whenever any person is within the spill response zones or any area that may be threatened as a result of the spill.

### Safety Briefing

Response personnel and others authorized to enter the response area must be briefed on the content of the Site Safety Plan prior to entering the site. The person assigned to be responsible for site safety or their delegate will conduct this briefing. A copy of the Site Safety Plan must be available for reference at the spill site. Responders must also have access to the Safety Data Sheet (SDS) for the spilled product if the SDS does not form part of the Site Safety Plan.

1. SDS provide detailed hazard, precautionary, protection, and emergency information on hazardous products and may be obtained from the manufacturer or supplier of the product. Copies of SDS shall be available for all products used or handled at spill sites.
2. A copy of the appropriate SDS should be attached to the Site Safety Plan.
3. Contractors are required to have SDSs available for all products that they bring to spill sites.
4. The appropriate SDS or Emergency Response Guidebook should be referred to for spills or leaks of substances not specifically covered by this plan.

### Initial Site Safety and Hazard Control Plan

An Initial Site Safety and Hazard Control Plan should be completed as soon as possible by one of the initial responders and updated as required. When completing the Initial Site Safety and Hazard Control Plan, some of the information may not apply during the initial stages of the response but may change within a short period, thereby altering the PPE and/or other requirements.

---

## **SPILL RESPONSE, continued**

### **The Initial Site Safety and Hazard Control Plan:**

1. Aids the initial first responders in assessing hazards related to the incident.
2. States the required PPE to be used.
3. Documents important health and safety information.
4. Serves as an interim "Plan" until a Site Safety Plan is developed.
5. Assigns responsibilities.
6. Identifies "site set-up" features that may be required.
7. Upon the completion and delivery of the Site Safety Plan, the Initial Site Safety and Hazard Control Plan becomes "void".

### **Western Canadian Spill Services (WCSS)**

WCSS maintains spill contingency plans and provides spill response equipment to all member companies that do not maintain their own full spill response plans.

WCSS - <http://www.wcss.ab.ca/>

Spill Contingency Plan - <http://www.wcss.ab.ca/contingency-manual.shtml>

Live Equipment Report - <http://wcss.ab.ca/emis>

This page is intentionally left blank

## Upstream Petroleum Industry – Spill & Release Reporting Requirements

### All Spills must be reported to your Ovintiv EHS Advisor (IMS)

Minimum Reportable Quantity			
*** If the released product reaches off-site all releases must be reported, regardless of a minimum quantity			
Alberta (see Note 1)		British Columbia (see Note 2)	
Any release that which may cause an adverse effect must be reported.		All releases must be reported, regardless of a minimum reportable quantity, if the release of a "polluting substance" is causing "pollution".	
Product	On-Site	On-Site	Product
Unrefined products (Crude Oil, Condensate), Drilling Mud (all), Emulsions, Produced Water Any/All unrefined products, General Oilfield Wastes (See Note 6)	2 m <sup>3</sup>	100 L	Unrefined products (Crude Oil, Condensate), Drilling Mud (all), Emulsions, "Waste" Lube Oil, "Waste" Glycols, Diesel Fuel, Gasoline and Other Refined Flammable Liquids (Class 3) Methanol
Diesel Fuel, Gasoline and Other Refined Flammable Liquids (Class 3) Methanol	200 L	200 L	Produced Water
Fresh Water	May be reportable depending on volumes/mechanism of failure (e.g. berm or AWSS breach) impacts (sediment or erosion offsite) and whether the water was tested prior.	Unintentional release of 10 m <sup>3</sup> or if there are impacts (sediment or erosion offsite) and whether the water was tested prior.	Fresh Water
Pipeline Incidents (leak, break, contact)	Any Licensed Pipeline	Any Permitted Pipeline	Pipeline Incidents (leak, break, contact)

Natural Gas (Flare and Vent) -			
Natural Gas	30 e3m <sup>3</sup> for any release caused by a leak or break. For other intentional venting refer to Directive 060 section 8. (See Note 5)	10 kg (0.012 E <sup>3</sup> M <sup>3</sup> ) if breakage in a pipeline or fitting operated above 100 psi and results in a sudden & uncontrolled release of natural gas. (See Note 7)	
Permit/ Approval Conditions	Report as per approval	Report as per permit	
Solution Gas Flaring	Per Table 1 of Directive 060. Potential inlet reductions and notifications (AER and resident) after 4 hours via DDS.	Notify the BCER if non-routine flaring event exceeds 10 e3m <sup>3</sup> . For resident notification guidelines refer to Section 6 of the Flaring and Venting Reduction Guidelines	
Temporary and gas Facility flaring	Per Table 2 of Directive 060. Notifications required (AER and resident) after 4 hours or greater than 30 E <sup>3</sup> M <sup>3</sup> via DDS.		

Report to:			
Product Releases and incidents	<b>Alberta Energy Regulator 1-800-222-6514</b> Oral report immediately to above. A written 7-day report may be requested. Report any pipeline or off-site release to AER and notify landowner.	<b>B.C. Energy Regulator (BCER) via the Emergency Mgmt. Climate Readiness (EMCR) 1-800-663-3456</b> Oral report immediately to above. Written report may be required by the BCER within 14 days or 30 days as required by BCER Emergency Response Plan Requirements, Section 4.8. Minor incidents must be submitted within 24 hours by electronic submission through KERMIT. Form D (Post Incident Report) required for all Level 1 or greater emergencies or any pipeline incident within 60 days	
Releases during transport (Endanger or could endanger public safety)	<b>Releases during transport should be immediately reported to local Police and 1-800-272-9600 (AB Transportation)</b> Written report within 30 days to Transport Canada for TDG regulated product releases. TDGR also requires reporting to the consignor of the dangerous goods; the owner, lessee or charterer of the road vehicle; and, for an accidental release from a cylinder that has suffered a catastrophic failure, <b>CANUTEC at 613-996-6666.</b>	<b>Emergency Mgmt. Climate Readiness (EMCR) 1-800-663-3456</b> Written report may be required by the MOE. Written report within 30 days to Transport Canada for TDG regulated product releases. TDGR also requires reporting to the consignor of the dangerous goods; the owner, lessee or charterer of the road vehicle; and, for an accidental release from a cylinder that has suffered a failure <b>CANUTEC at 613-996-6666.</b>	
Federal Regulated Releases	<ul style="list-style-type: none"> <li>Report to Environment Canada 1-780-499-2432 for any release of a deleterious substance directly or indirectly (including through groundwater) into water frequented by fish.</li> <li>Canada Energy Regulator (CER) regulated pipelines require immediate reporting of all incidents as defined in the Onshore Production Regulations (OPR) &amp; as further described in the CER Event Reporting Guidelines. Releases of LVP in excess of 1.5 m<sup>3</sup>, sweet natural gas or HVP in excess of 30 103 m<sup>3</sup> or any uncontrolled release of sour natural gas requires immediate reporting via the Transportation Safety Board (TSB) Hotline at (819) 997-7887 and through the Online Event Reporting System (OERS). Unauthorized activity such as ground disturbance, construction activity or nonauthorized vehicle crossings also requires immediate reporting. For any questions contact the Ovintiv Regulatory Compliance Group or for a copy of the CER Event Reporting Summary.</li> <li>Radioactive releases to be immediately reported to any CNSC (Canadian Nuclear Safety Commission) office and a full report filed within 21 days. CNSC Western Regional Office 403-292-5181.</li> </ul>		

Notes:	
1	In Alberta: An unrefined product spill is reportable above the threshold quantity (2 m <sup>3</sup> ) even if the release does not contact the environment (e.g. contained within a building or secondary containment) while refined product spills must be into the environment – This is due to applicable act/regulation wording. All releases must be reported, regardless of minimal reportable quantities, if the release has caused, is causing or may cause an adverse effect. An "adverse effect" is defined as impairment of or damage to the environment, human health or safety or property".
2	In B.C.: All releases must be reported, regardless of a minimum reportable quantity, if the release of a "polluting substance" is causing "pollution". "Polluting substance" is any substance, whether gaseous, liquid, or solid that is capable of causing pollution, if it were to escape to air, or be spilled or escape onto land or into a water body. "Pollution" is the presence in the environment of substances or contaminants that substantially alter or impair the usefulness of the environment. Any fluid including hydrocarbons, drilling fluids, invert mud etc. which contain toxic substances must be reported at 5 L.
3	Transportation refers to the TDG and means all handling, offering for transport, and transporting of dangerous goods, by any means of transport. Handling means loading, unloading, packing or unpacking dangerous goods in a means of containment for the purposes of, in the course of or following transportation, includes storage in the course of transportation also including inside buildings and secondary containment. Transportation does not include by pipelines.
4	Waste and TDG classification is variable. Refer to the product's MSDS to determine TDG classification; in particular amines and inhibitors can be a variety of classifications (i.e. corrosive, flammable etc.). Refer to the <i>Ovintiv Shipping Management Chart</i> for waste information. Some products may have to be reported by their secondary TDG classification (e.g. methanol). For Alberta refer also to the Table in Part 8, Section 8 of the TDG Regulations. For BC refer also to the Spill Reporting Regulations. Produced water, lube oil and hydraulic oil are not typically TDG regulated products unless it contains a regulated component(s).
5	Additional AER immediate reporting requirements include: any fire where the loss exceeds 2 m <sup>3</sup> of oil or 30 e3m <sup>3</sup> of gas or fire caused by a flare stack or any event that causes the activation of a level 1 emergency or higher; also any unexplained loss or theft of oil or condensate exceeding 2 m <sup>3</sup> , any damage to or uncontrolled flow from a wellhead or any smoke emissions that may result in public concerns; also any gas release exceeding 30 e3m <sup>3</sup> per Directive 60 Table 1 and Table 2 or any casing leak or failure; any contact leak or break in a pipeline; any leak in a pipeline during pressure testing. Also notify the AER of gas plant turnaround at least 24 hours in advance. Also note that venting is not considered an acceptable alternative to flaring and gas should be burned if the volumes and flow rates will support stable combustion. Venting should not result in an unacceptable fire or explosion hazard and should not result in off-lease odors (consult EHS staff to discuss whether odors require notification). Also note that all flared and vented volumes should be measured or estimated and reported to the AER via ACTS/Production Accounting if the volumes are greater than 0.1 e3m <sup>3</sup>
6	AER definition of an oilfield waste is "An unwanted substance (by the generator) or mixture of substances that results from the construction, operation or reclamation of a well site, oil and gas battery, gas plant, compressor station, crude oil terminal, pipeline, gas gathering system, heavy oil site, oil sands site or related facility.
7	Report to the BCER any damage or malfunction likely to cause spillage that could be a risk to the public safety or the environment including all pipeline incidents. Well control incidents should be reported to EMCR and the BCER directly at 1-250-794-5200. Spills and incidents that do not reach an emergency level 1, 2 or 3 (minor incident score 2 or less) also require reporting on the On-line Minor Incident Reporting system within 24 hours (Form A). Any level 1, 2 or 3 emergency incidents (including any pipeline related incidents) must be reported immediately to EMCR AND A Form D completed within 60 days.

## Spill Priorities:

- Establish site control
- Determine and control source of spill
- Contain the spill and prevent it from spreading
- Contact your supervisor
- Contact Environmental advisor
  - Report to Regulator if required and coordinate cleanup
  - Coordinate Waste handling, transportation and disposal
  - Record and compile information/reporting regarding the spill
- Clean up spill
- Enter into IMS

Process Safety Event Volume Reference Table																					
		60 minute gas released (m3)																			
1/4 inch ball valve % open	100	100	147	188	225	260	382	509	636	763	889	1016	1143	1270	1397	1523	1650	1777	1904	2030	
	75	75	110	140	168	195	286	381	475	571	668	760	856	951	1045	1140	1235	1330	1425	1520	
	50	50	73	94	112	130	191	254	317	380	443	507	570	633	696	760	823	886	949	1012	
	25	25	37	47	56	65	96	127	159	191	222	254	286	317	349	381	412	444	476	508	
	10	10	15	19	22	26	38	51	64	76	89	102	114	127	140	152	165	178	190	203	
	5	5	7	9	11	13	19	25	32	38	44	51	57	63	70	76	83	89	95	102	
		20	40	60	80	100	200	300	400	500	600	700	800	900	1000	1100	1200	1300	1400	1500	
		Source pressure (kPag)																			
		not a PSE						PSE (I) indoor						PSE (O) outdoors							

# Containment and Recovery

## Understanding Environments – Ground and Water

A spill can occur in several different environments. The type of environment will influence the most appropriate technique to be used for the response strategy, while the fate of oil will be influenced by many other situational and local factors. The response can be complicated due to geophysical and environmental factors that can affect the oil spill's behavior.

	Ground	
	Permeable Ground	Impermeable Ground
Understand oil behavior:	Oil on permeable ground will flow in both horizontal and vertical directions. Penetration of ground will depend on the oil type and the porosity and permeability of the surface materials.	Oil on impermeable ground will either remain relatively static on the terrain or follow the path of least resistance if a slope is present. It is likely to collect in depressions and watercourses.
Identify resources at risk:	Examples of resources needing protection include: <ul style="list-style-type: none"> <li>• Non-vegetated: mud/silt; sand; pebble/boulders.</li> <li>• Vegetated: grassland; forest; wetland.</li> </ul>	Examples of resources needing protection include: <ul style="list-style-type: none"> <li>• Drainage systems</li> <li>• Watercourses</li> <li>• Utilities</li> </ul>
Response Considerations:	<ul style="list-style-type: none"> <li>• Penetration of soil below the uppermost layer must be minimized.</li> <li>• Prevent oil from entering areas with ground water.</li> <li>• Drains and inlets should be blocked.</li> </ul>	<ul style="list-style-type: none"> <li>• Oil should be contained as soon as possible.</li> <li>• Any flowing oil should be intercepted quickly to prevent further contamination of the surface.</li> <li>• Drains and inlets should be blocked.</li> </ul>

**Permeable Ground**

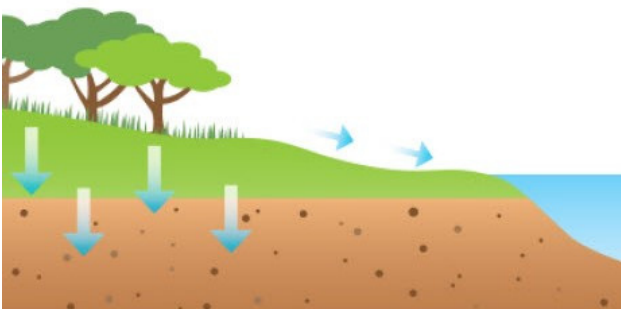

**Impermeable Ground**



## Containment and Recovery, continued

	Water	
	Static Water	Moving Water
Understand oil behavior:	Oil on static water will float, spreading to form a thin surface layer. Water is rarely truly “static”, with wind-induced waves causing spilled oil to drift.	Oil can be rapidly transported by moving water, following the direction of both wind and currents. The oil generally spreads to form a thin surface layer and will also be subjected to significant weathering processes.
Identify resources at risk:	Examples of resources needing protection include: <ul style="list-style-type: none"> <li>• Ponds</li> <li>• Lakes</li> <li>• Reservoirs</li> </ul>	Examples of resources needing protection include: <ul style="list-style-type: none"> <li>• Rivers</li> <li>• Streams</li> <li>• Water intakes</li> <li>• Fishing areas</li> </ul>
Response Considerations:	<ul style="list-style-type: none"> <li>• Prevent oil from spreading beyond the water body and contaminating further surfaces.</li> <li>• Consider impact of oil moving into vegetated areas such, as reed beds. This will act to trap oil making it more difficult to recover.</li> </ul>	<ul style="list-style-type: none"> <li>• Oil should be contained as soon as possible and collected.</li> <li>• Intercept oil flowing downstream to prevent further contamination, while protecting resources at risk.</li> </ul>

**Static Water**



**Moving Water**



# Containment and Recovery, continued

## Containment of Spilled Product

### On Permeable Ground

Permeable ground will pose challenges to the containment of oil as it flows in both a horizontal and vertical direction and will travel with the direction of groundwater flow once it is reached.

#### 1. Response Priorities

When responding to a spill on permeable surfaces, it is important to minimize the amount of oil that can penetrate below the surface; this should require the oil to be spread over a large surface area in the attempt to reduce head pressure on the surface to prevent penetration. This may well be the preferable option compared to long-term operations of subsoil and groundwater clean-up.

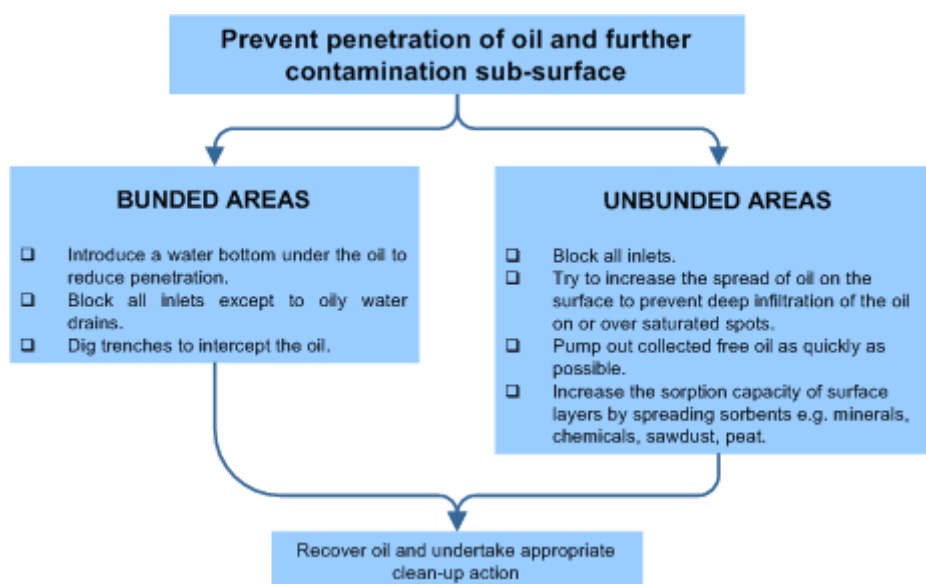

#### 2. Retention Capacities in Permeable Surfaces

Each type of permeable surface will allow oil to permeate at different rates and will retain oil at varying capacities. Although the pore spaces in coarser soils are larger, oil will flow through more readily (due to gravity) thus giving a lower retention capacity.

Finely packed sediments retain the oil in two ways; first, the oil molecules cannot pass so easily between the particles due to their size and secondly because the forces associated with capillary action hold the oil in the pore spaces.

Surface area is also a factor in retention capacities; small grain sediments have a higher surface area and therefore hold more oil on the surface of the grains than larger grained sediments.

## Containment and Recovery, continued

Surface Type	Capacity (ltrs/m <sup>3</sup> )
Stones / Coarse Gravel	5
Gravel / Coarse Sand	8
Coarse Sand / Medium Sand	15
Medium Sand / Fine Sand	25
Fine Sand / Silt	40

*Note: Groundwater movement is very slow, usually between 0.5 m and 1.5 m per day. If oil reaches below subsurface layers, a study of the underlying hydrogeology to identify the most optimal location for the recovery of oil. Different recovery methods can then be put in place, preventing both the further spread of the oil, and flushing from the groundwater system.*

### On Impermeable Ground

Spill on impermeable ground will remain static until it is recovered, unless a gradient is present that may cause it to spread.

#### 1. Response Priorities

If spills on impermeable ground, the response should first prevent the oil from further spreading and potentially contaminating other surface areas. Once contained, the oil will then need to be recovered through either manual or mechanical methods.

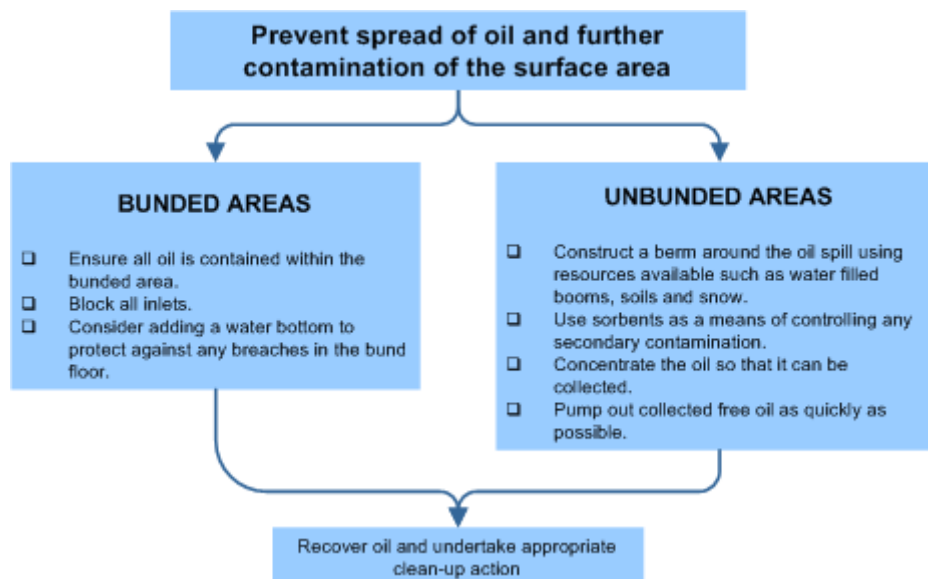

## Containment and Recovery, continued

### 2. Spills in Urban Areas

Urban and built-up areas will contain a vast amount of man-made surface areas sitting alongside natural environments. These man-made surface areas will often be impermeable in nature, so prevention of spread and containment remains the main priority, however, urban areas also pose a significant health and safety risk.

Urban areas are likely to feature intricate drainage and sewage systems, therefore important to prevent the spread of oil to these highly sensitive areas where there is a risk of either contamination with sewage treatment plants and/or watercourses by:

- Using dams formed from soil, sandbags, or sorbents to protect inlets.
- Seal drain gratings with plastic bags filled with water and sand.

Oil and the associated fumes can also be highly volatile. As the vapours are heavier than air, it will gather in underground lines, wells, and troughs. This leads to an increased explosion risk; therefore, it is essential to minimize the potential of ignition, ensuring that:

- Traffic is stopped and other ignition sources are extinguished.
- Any affected system operators such as utilities, telephone and railways are informed.

### On Static Water

On larger areas of static water, boom can be used to contain the floating oil. The water bodies can be subject to wind-induced wave action, causing the oil to drift, therefore making it necessary to prioritize the containment to prevent further spreading. Where lakes etc. are fed and drained by watercourses, their inlets and outlets need to be protected, methods described in oil on moving water can be utilized.

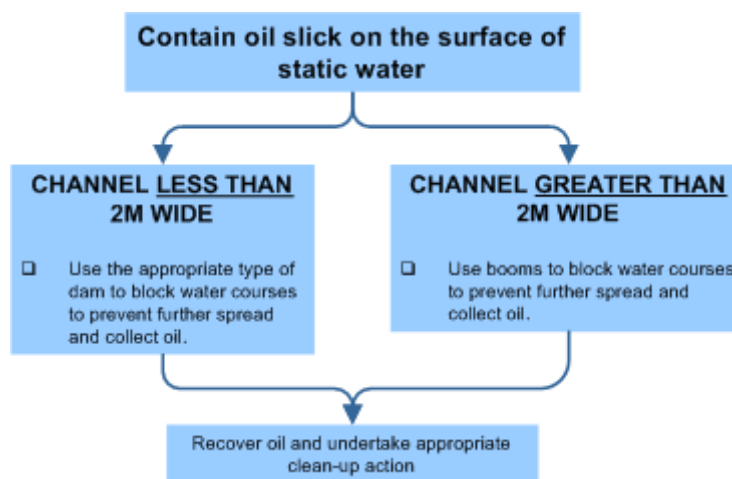

## Containment and Recovery, continued

### On Moving Water

For spills that occur in rivers with currents more than 0.5 m/s, various techniques, and equipment, including booms and dams, have been developed to suit the relevant environmental conditions. In currents faster than 1 m/s, it is advisable to use techniques that allows water to flow freely subsurface while containing the oil solely on the surface of the water, such as a sorbent fence, inverted weir, culvert block, water gate or turner valley gate.

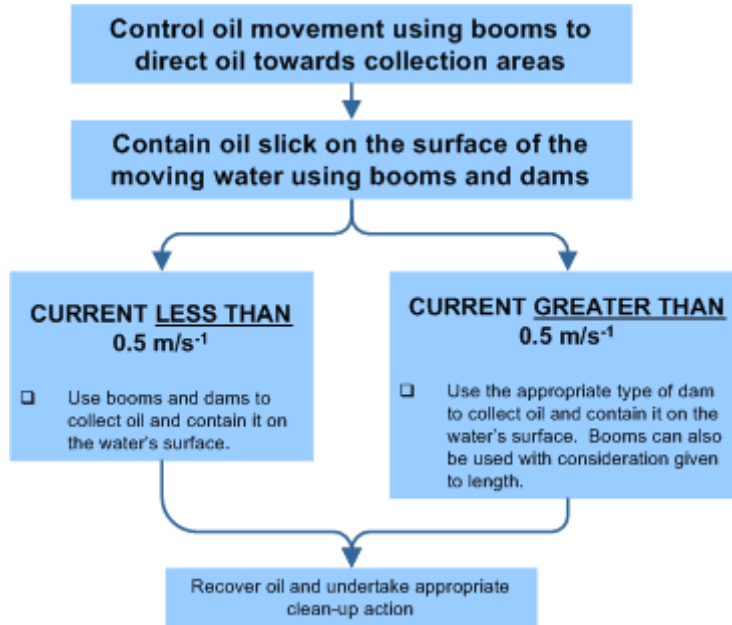

## Containment and Recovery, continued

### Containment to Recovery Process for Moving Water

Booms can be used to direct the flow of oil, limit any further spread, and then contain it on the water's surface ready for recovery. Different techniques can be employed depending on the quantity of oil spilled and the surrounding operational and environmental conditions, such as the width and windings in the channel of a river, stream, or other watercourse.

If there are pre-determined control point tactical plans this will also guide the location, personnel and equipment required to implement the containment to recovery process.

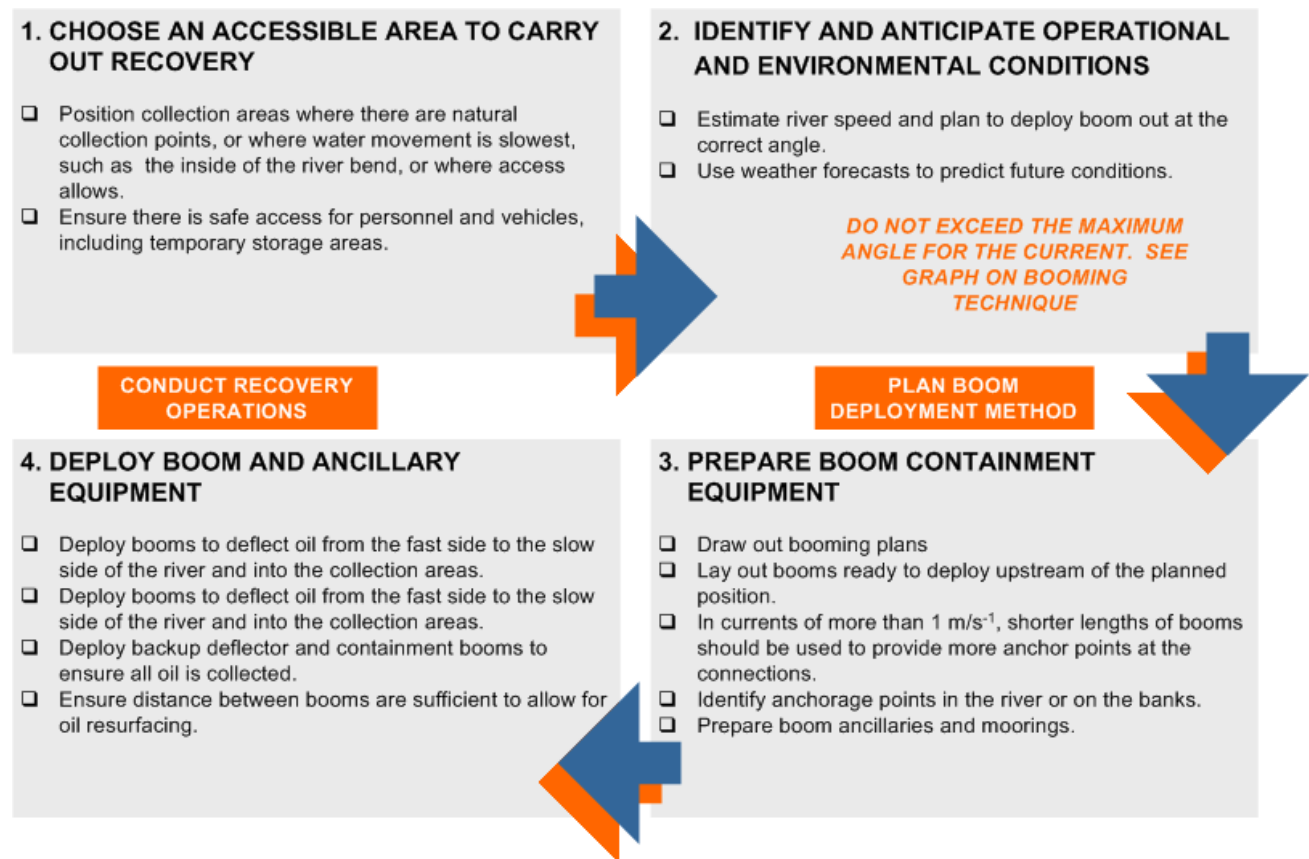

# Containment and Recovery, continued

## Recovery of Spilled Product

A range of response strategies are available to the responder, dependent on resources accessibility. Each strategy will require a level of expertise, coordination and is likely to generate waste. These factors should also be considered when deciding on the most appropriate clean-up method to use.

### Natural Recovery

In some areas, it may be less environmentally damaging to allow the area to recover naturally. Natural recovery is a slow process; however, it may be the only course of action from a safety and operational perspective.



### Manual Clean Up

Manual recovery is a labor-intensive strategy that utilizes large numbers of people collecting stranded oil with the necessary tools; shovels, buckets, etc.



### Mechanical Recovery

Oil can be removed from the surface using a multitude of machinery, including pumps and vacuum equipment, scrapers, graders, and oil skimmers.



### Use of Water

Flooding can cause the oil to float on the water, this allows it to be recovered later by pumps and skimmers. Flushing can be used to remobilize the oil from the soil and/or wash it from the surface. Both techniques should be used carefully, and containment boom in place to prevent further spread.



### Sorbents

Sorbents, made of oleophilic materials; natural (straw) and synthetic (polypropene), can be introduced to the area to selectively absorb the oil while repelling water.



### In-Situ Burn

In-situ burning may be considered when physical recovery is not feasible. It is best used in remote areas, especially where roots are protected by high water levels. Some environments may recover from burning more readily than if left oiled without treatment.



## Containment and Recovery, continued

### Recovery Techniques

Technique	Description	Equipment / Resources	Applicability	Environmental Impacts
<b>Manual Clean Up</b>	Hand tool (scrapers, wire brushes, shovels, cutting tools, wheelbarrows, etc.) are used to scrape oil off surfaces or recover oiled sediments, vegetation, or debris where oil conditions are light or sporadic and/ or access is limited.	<ul style="list-style-type: none"> <li>• Shovels</li> <li>• Buckets</li> <li>• Sorbents</li> <li>• (10-20) labourers</li> </ul>	<ul style="list-style-type: none"> <li>• Can be used on all habitat types</li> <li>• Light to moderate oiling conditions for stranded oil or heavy oils that have formed semi-solid to solid masses</li> <li>• In areas where roosting or birthing animals cannot or should not be disturbed.</li> </ul>	<ul style="list-style-type: none"> <li>• Sediment disturbance and erosion potential.</li> </ul>
<b>Mechanical Removal</b>	Mechanical earthmoving equipment is used to remove oiled sediments and debris from heavily impacted areas with suitable access.	<ul style="list-style-type: none"> <li>• Motor grader,</li> <li>• Backhoe</li> <li>• Dump truck</li> <li>• Elevating scrapers</li> <li>• (2-4) labourers</li> <li>• Equipment operators</li> </ul>	<ul style="list-style-type: none"> <li>• On land, wherever surface sediments are accessible to heavy equipment</li> <li>• Large amounts of oiled materials.</li> </ul>	<ul style="list-style-type: none"> <li>• Removes upper 5 to 30 cm of sediments.</li> </ul>
<b>Sorbent Use</b>	Sorbents are applied manually to oil accumulations, coatings, sheens, etc. to remove and recover the oil.	<ul style="list-style-type: none"> <li>• Hand tools</li> <li>• Sorbents</li> <li>• (2-10) labourers</li> </ul>	<ul style="list-style-type: none"> <li>• Can be used on all habitat types</li> <li>• Free-floating oil close to shore or stranded on shore, secondary treatment method after gross oil removal</li> <li>• Sensitive areas where access is restricted.</li> </ul>	<ul style="list-style-type: none"> <li>• Sediment disturbance and erosion potential</li> <li>• Trampling of vegetation and organisms</li> <li>• Foot traffic can work oil deeper into soft sediments.</li> </ul>
<b>Vacuum / Pumps / Skimmers</b>	Pumps, vacuum trucks, skimmers are used to remove oil accumulations from land or relatively thick floating layers from the water.	<ul style="list-style-type: none"> <li>• (1-2) - 50 to 100 bbl vacuum trucks w/ hoses</li> <li>• (1-2) nozzle screens or skimmer heads</li> <li>• (2-6) labourers</li> <li>• truck operators</li> </ul>	<ul style="list-style-type: none"> <li>• Can be used on all habitat types</li> <li>• Stranded oil on the substrate</li> <li>• Shoreline access points.</li> </ul>	<ul style="list-style-type: none"> <li>• Typically, does not remove all oil</li> <li>• Can remove some surface organisms, sediments, and vegetation.</li> </ul>
<b>Flooding</b>	High volumes of water at low pressure are used to flood the oiled area to float oil off and out of sediments and back into the water or to a containment area where it can be recovered. Frequently used with flushing.	<ul style="list-style-type: none"> <li>• (1-5) - 380 to 750 lpm pumping systems</li> <li>• (1) – 100 ft perforated header hose per system</li> <li>• (1-2) – 200 ft containment booms per system</li> <li>• (1) oil recovery device per system</li> <li>• (6-8) labourers per system</li> </ul>	<ul style="list-style-type: none"> <li>• All shoreline types except steep intertidal areas</li> <li>• Heavily oiled areas where the oil is still fluid and adheres loosely to the substrate</li> <li>• Where oil has penetrated gravel sediments</li> <li>• Used with other washing techniques.</li> </ul>	<ul style="list-style-type: none"> <li>• Can impact clean down gradient areas</li> <li>• Can displace some surface organisms if present</li> <li>• Sediments transported into water can affect water quality.</li> </ul>

## Containment and Recovery, continued

Technique	Description	Equipment / Resources	Applicability	Environmental Impacts
<b>Flushing</b>	Water streams at low to moderate pressure, and possibly elevated temperatures, are used to remove oil from surface or near-surface sediments through agitation and direct contact. Oil is flushed back into the water or a collection point for subsequent recovery. May also be used to flush out oil trapped by shoreline or aquatic vegetation.	<ul style="list-style-type: none"> <li>• (1-5) - 189 to 380 lpm / 689 kpa pumping systems with manifold</li> <li>• (1-4) - 30 m hoses and nozzles per system</li> <li>• (1-2) - 60 m containment booms per system</li> <li>• (1) oil recovery device per system</li> <li>• (8-10) labourers per system</li> </ul>	<ul style="list-style-type: none"> <li>• Substrates, riprap, and solid man-made structures</li> <li>• Oil stranded onshore</li> <li>• Floating oil in shallow areas.</li> </ul>	<ul style="list-style-type: none"> <li>• Can impact clean down gradient areas</li> <li>• Will displace many surface organisms if present</li> <li>• Sediments transported into water can affect water quality</li> <li>• Hot water can be lethal to many organisms</li> <li>• Can increase oil penetration depth.</li> </ul>
<b>High Pressure Washing</b>	High pressure water streams are used to remove oil coatings from hard surfaces in small areas where flushing is ineffective. Oil is directed back into water or collection point for subsequent recovery.	<ul style="list-style-type: none"> <li>• (1-5) - 1,200 to 4,000 psi units with hose and spray wand</li> <li>• (1-2) - 30 m containment booms per unit</li> <li>• (1) oil recovery device per unit</li> <li>• (2-4) labourers per unit</li> </ul>	<ul style="list-style-type: none"> <li>• Bedrock, man-made structures, and gravel substrates</li> <li>• When low-pressure flushing is not effective</li> <li>• Directed water jet can remove oil from hard-to-reach sites.</li> </ul>	<ul style="list-style-type: none"> <li>• Will remove most organisms if present</li> <li>• Can damage surface being cleaned</li> <li>• Can affect clean down gradient or nearby areas.</li> </ul>
<b>Sediment Tilling</b>	Mechanical equipment or hand tools are used to till lightly to moderately oiled surface sediments to maximize natural degradation processes.	<ul style="list-style-type: none"> <li>• (1) tractor fitted with tines, dicer, ripper blades, etc., or</li> <li>• (1-4) rototillers</li> <li>• hand tools</li> <li>• (2-10) labourers</li> </ul>	<ul style="list-style-type: none"> <li>• Any sedimentary substrate that can support heavy equipment</li> <li>• Sand and gravel beaches with subsurface oil</li> <li>• Where sediment is stained or lightly oiled</li> <li>• Where oil is stranded above normal high waterline.</li> </ul>	<ul style="list-style-type: none"> <li>• Significant amounts of oil can remain on the shoreline for extended periods of time</li> <li>• Disturbs surface sediments and organisms.</li> </ul>
<b>Log / Debris Burning</b>	Oiled logs, driftwood, vegetation, and debris are burned to minimize material handling and disposal requirements. Material should be stacked in tall piles and fans used to ensure a hot, clean burn.	<ul style="list-style-type: none"> <li>• (1) set of fire control equipment</li> <li>• (2-4) fans</li> <li>• (1) supply of combustion promoter</li> <li>• (2-4) labourers</li> </ul>	<ul style="list-style-type: none"> <li>• On most habitats except dry muddy substrates where heat may impact the biological productivity of the habitat</li> <li>• Where heavily oiled items are difficult or impossible to move</li> <li>• Many potential applications on ice.</li> </ul>	<ul style="list-style-type: none"> <li>• Heat may impact local near-surface organisms</li> <li>• Substantial smoke may be generated</li> <li>• Heat may impact adjacent vegetation.</li> </ul>
<b>Natural Recovery</b>	No action is taken, and oil is allowed to degrade naturally	<ul style="list-style-type: none"> <li>• None required</li> </ul>	<ul style="list-style-type: none"> <li>• All habitat types</li> <li>• When natural removal rates are fast</li> <li>• Oiling is light</li> <li>• Access is severely restricted or dangerous to cleanup crews</li> <li>• When cleanup actions will do more harm than natural removal.</li> </ul>	<ul style="list-style-type: none"> <li>• Oil may persist for significant periods of time</li> <li>• Remobilized oil or sheens may impact other areas</li> <li>• Higher probability of impacting wildlife.</li> </ul>

# SORBENTS



Sorbents can be used to recover oil product that can not be easily recovered using mechanical methods. They are predominately single-use products. When allowed to come in contact with oil on water, they will absorb or adsorb the oil over time.

## Objectives

- ◇ Prevent further migration of released products.
- ◇ Recover released product in areas that it may be difficult to reach.



## Safety

- ◇ Identify hazards and complete a site safety plan.
- ◇ Consider toxic and flammable vapours.
- ◇ Adjacent infrastructure such as powerlines, pipelines, and underground services.
- ◇ Waders, safety harness, line and PFD may be required.



## Environmental Consideration

- ◇ Utilize existing access and routes to minimize disturbance of soils. Consider environmental sensitivities such as vegetation soil types and wildlife/fish habitat.
- ◇ Ensure decontamination areas have been established to minimize transfer of released product during site assessment and site preparation activities.
- ◇ Consider air quality issues and proximity of stakeholders.



## Equipment / Resources

- ◇ Sorbents
- ◇ Waste disposal bags
- ◇ Gloves



## Personnel

- ◇ Supervisor / lead
- ◇ Site safety
- ◇ Labourers



## Procedure

- ◇ Use sorbents to soak up and recover released product.
- ◇ Place used sorbents in waste bags for off-site disposal.



## SORBENT PADS

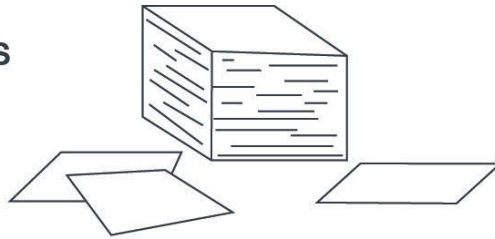

## Sorbent Pads

- ◇ Generally smaller in size. Useful for spot cleaning by hand.

## SORBENT BOOMS

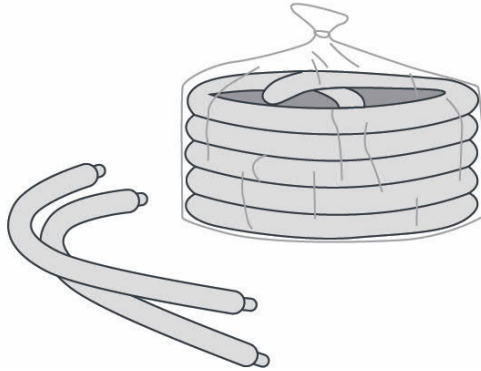

## Sorbent Booms

- ◇ Sorbent booms are easily deployed in low current environments.
- ◇ Usually sausage-shaped, with a few inches of height above the water when floating.



## Sorbent Sweeps

- ◇ Long, narrow sheets of sorbent material with an integral tension member.
- ◇ Sorbent sweeps can be used in place of sorbent booms for managing and recovering sheens.

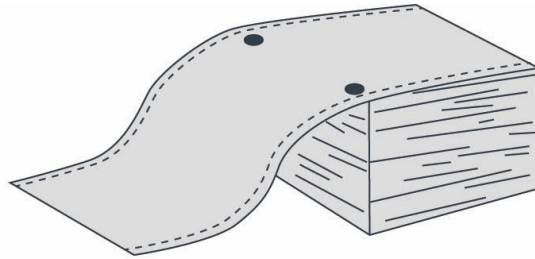

## SORBENT SWEEPS

## Sorbent Socks

- ◇ A smaller, more compact version of sorbent booms.
- ◇ Useful for building small containment walls around storm drains, sumps, bilges or sewer entries.

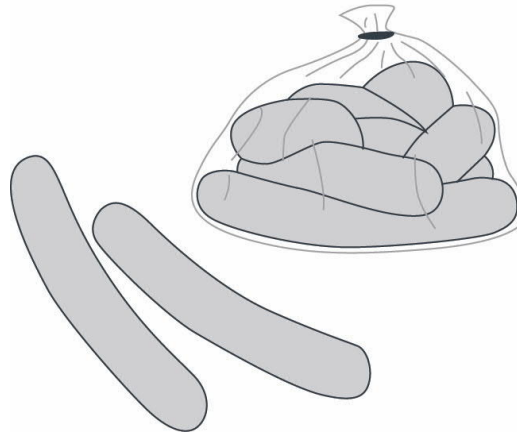

## SORBENT SOCKS



# BERMS



Berms can be constructed using any non-porous material using mechanical or hand equipment. They can be used to prevent migration of released product as well as used to divert surface flow from areas that have been impacted by a spill. They are used in conjunction with other containment and recovery methods such as trenches, bell holes and inverted weirs.

## Objectives

- ◇ To halt the advance of spilled product and allow for the recovery of the spilled product.
- ◇ Contain and prevent further migration of released products by channeling the spill in a particular direction
- ◇ Create a pooled area for recovery of released product.
- ◇ Diversion of surface flows from impacted area.



## Safety

- ◇ Identify hazards and complete a site safety plan.
- ◇ Consider toxic and flammable vapours.
- ◇ Adjacent infrastructure such as powerlines, pipelines, and underground services.
- ◇ Establish communications in remote areas.
- ◇ Be cautious of wildlife.



## Environmental Consideration

- ◇ Utilize existing access and routes to minimize disturbance of soils. Consider environmental sensitivities such as vegetation soil types and wildlife/fish habitat.
- ◇ If possible, remove and conserve topsoil for reclamation activities. Avoid constructing berms with topsoil material.
- ◇ Ensure decontamination areas have been established to minimize transfer of released product during construction of berm.
- ◇ Handle and dispose of contaminated wastes in an approved manner.



## Equipment / Resources

- ◇ Shovels and/or earth moving equipment
- ◇ Plastic sheeting
- ◇ Sorbents
- ◇ Vacuum truck / portable vacuum unit



## Personnel

- ◇ Supervisor / lead
- ◇ Site safety
- ◇ Labourers
- ◇ Vacuum truck operator



## Procedure

- ◇ Lay plastic on ground, across expected route of spill travel.
- ◇ Pile non-porous materials on downstream side of plastic (away from approaching oil).
- ◇ Flip upstream side of plastic sheet over berm to prevent contamination of berm contents.
- ◇ Hand dig small bell hole upstream of berm recovery.
- ◇ Ensure waste disposal bags and tags if sorbents are to be used.

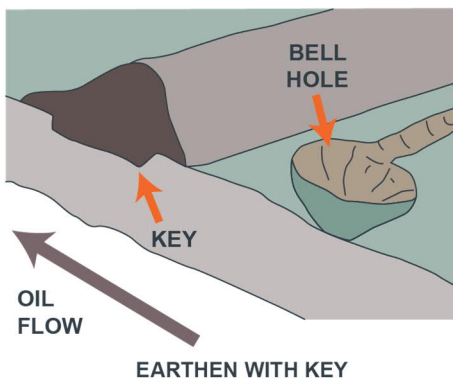

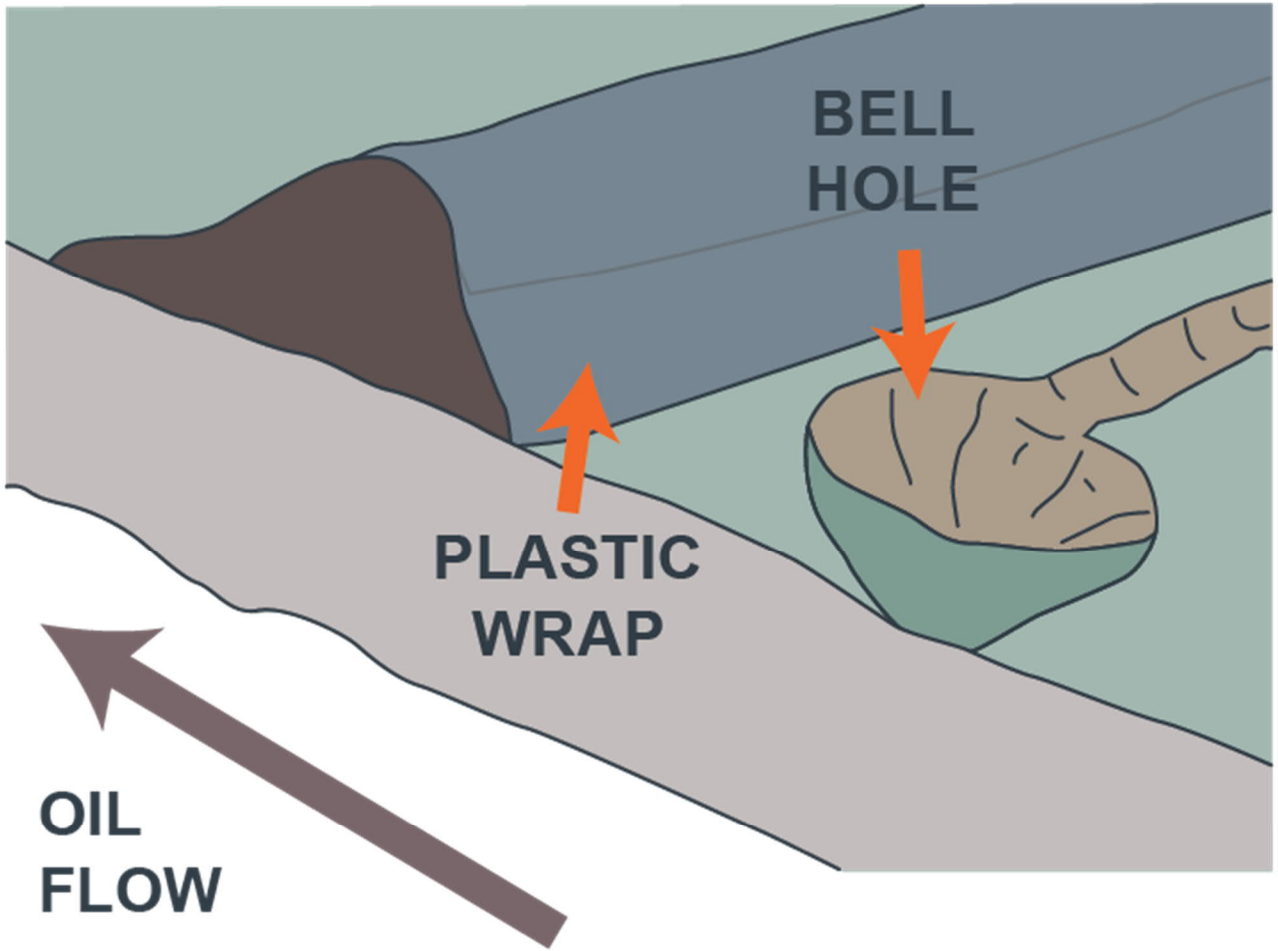

**EARTHEN PLASTIC WRAP**

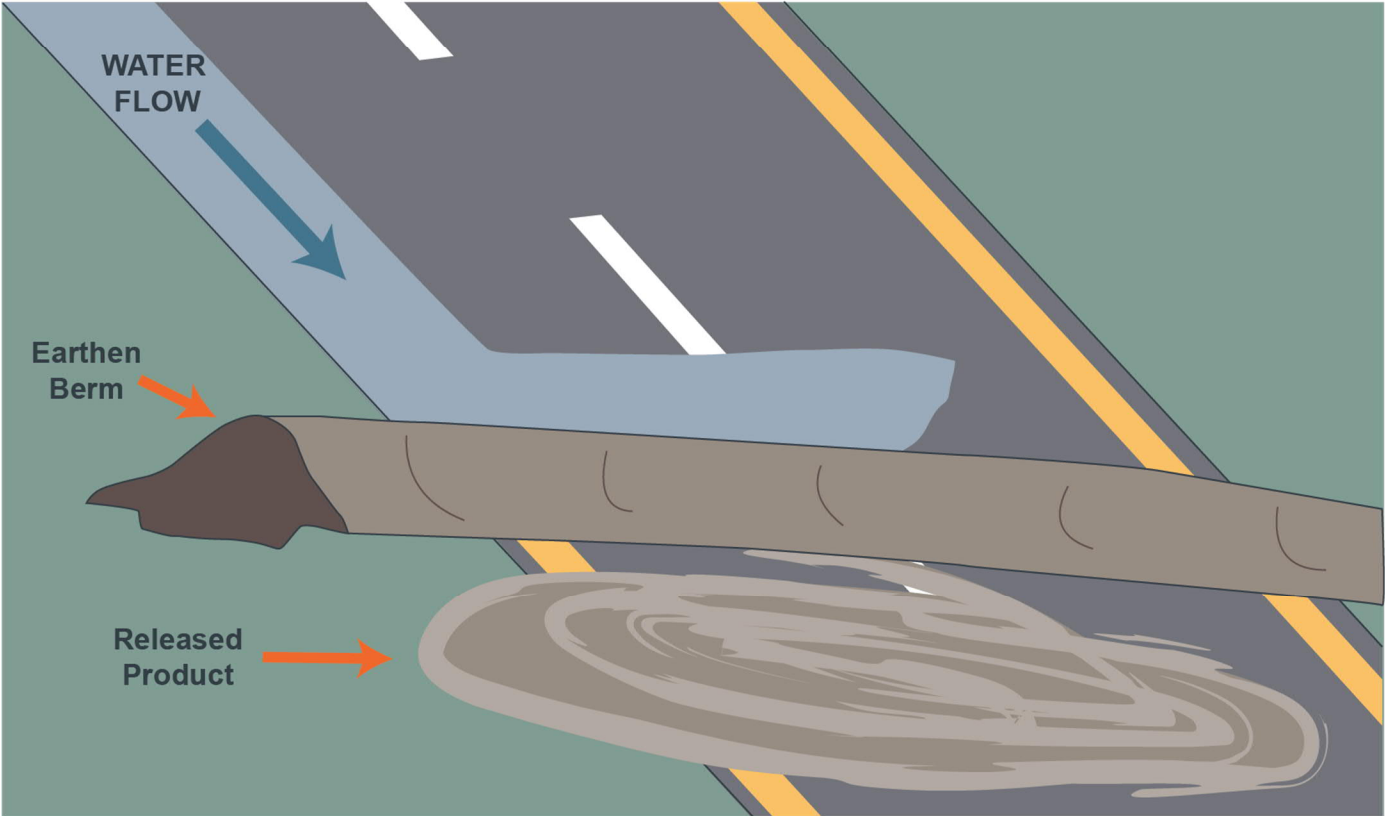

**SURFACE FLOW DIVERSION**

# TRENCHES AND BELL HOLES



Trenches can be excavated to contain a spill and used most commonly with bell holes to allow recovery of fluids and released product via vacuum unit or transfer pumps. For additional containment, the materials excavated from the trench can be used to construct berms downgradient of the trench. For larger spills, skimmers can be considered for recovery of released products.

## Objectives

- ◇ To halt the advance of the spilled product and allow for recovery while reducing potential for environmental damage.
- ◇ Provide capacity to recover released product and ensure containment.
- ◇ To stop spilled product where a significant containment capacity is required on a slope.



## Safety

- ◇ Identify hazards and complete a site safety plan.
- ◇ Consider toxic and flammable vapours.
- ◇ Adjacent infrastructure such as powerlines, pipelines, and underground services.
- ◇ Consider ground disturbance requirements.



## Environmental Consideration

- ◇ Utilize existing access and routes to minimize disturbance of soils. Consider environmental sensitivities such as vegetation soil types and wildlife/fish habitat.
- ◇ Utilize low lying areas to minimize depth of excavations.
- ◇ Keep trench depth at a minimum to prevent further sub-surface or groundwater impacts.
- ◇ Stockpile clean materials for reclaiming area of trenches and bell holes.
- ◇ Ensure decontamination areas have been established to minimize transfer of released product during construction of trenches and bell holes.



## Equipment / Resources

- ◇ Shovels / earth moving equipment
- ◇ Plastic sheeting
- ◇ Vacuum truck / vacuum unit
- ◇ Transfer pump / skimmer
- ◇ Temporary storage
- ◇ Containment booms
- ◇ Sorbents
- ◇ Hand lines



## Procedure

- ◇ Excavate shallow trench downstream and ensure berm is on downstream side of trench. Line the trench and berm with plastic sheeting to prevent contamination of berm contents.
- ◇ Excavate bell hole at low end of trench for the collection of fluids.
- ◇ Recover collected fluids using vacuum truck / vacuum unit or transfer pump into temporary storage.



## Personnel

- ◇ Supervisor / Lead
- ◇ Site Safety
- ◇ Labourers
- ◇ Vacuum truck operator



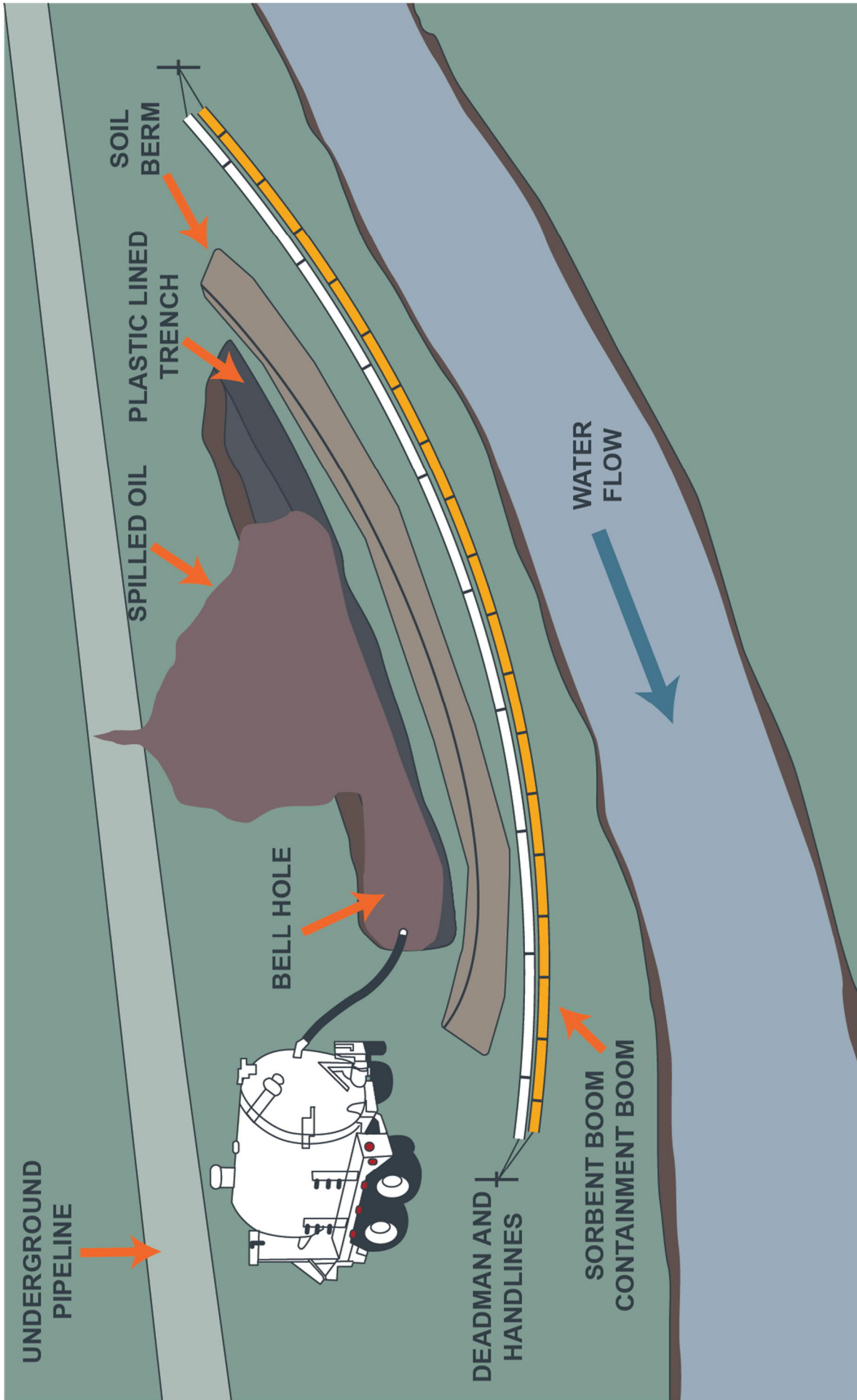

TRENCH AND BELL HOLE

# AQUADAM



Aquadam's are made up of multiple parallel chambers called fill tubes which give it a level of stability against shifting. While slightly more complicated to place and fill than a simple bladder, in many cases it does not require external anchors. Use in slow moving shallow watercourses.

## Objectives

- ◇ Contain and facilitate recovery of a water-borne spill from a ditch, creek or stream.
- ◇ Contain and prevent further migration of released products.
- ◇ Provide capacity to recover released product and impacted fluids.



## Safety

- ◇ Identify hazards and complete site safety plan.
- ◇ Consider toxic and flammable vapours.
- ◇ Adjacent infrastructure such as powerlines, pipelines, and underground services.
- ◇ Establish communications in remote areas.
- ◇ Be cautious of wildlife.



## Environmental Consideration

- ◇ Maintain control of damming materials to avoid introducing foreign substances into the watercourse.
- ◇ Utilize existing access routes to minimize disturbance of soils and care should be taken to minimize disturbance of watercourse and banks. Consider environmental sensitivities such as vegetation soil types and wildlife/fish habitat.
- ◇ Ensure decontamination areas have been established to minimize transfer of released product during setup.
- ◇ Handle and dispose of contaminated wastes in an approved manner.



## Equipment / Resources

- ◇ Aquadam / water bags
- ◇ Water source
- ◇ Trash pump / hose
- ◇ Suction hose
- ◇ Vacuum unit
- ◇ Skimmer



## Personnel

- ◇ Supervisor / lead
- ◇ Site Safety
- ◇ Labourers
- ◇ Vacuum truck operator



## Procedure

- ◇ Set up trash pump/hose.
- ◇ Prepare area by removing any sharp debris that could puncture or damage the aquadam.
- ◇ Unroll aquadam across the area of desired containment.
- ◇ Fill aquadam using trash pump and hose.
- ◇ Recover released product using skimmer / vac unit.



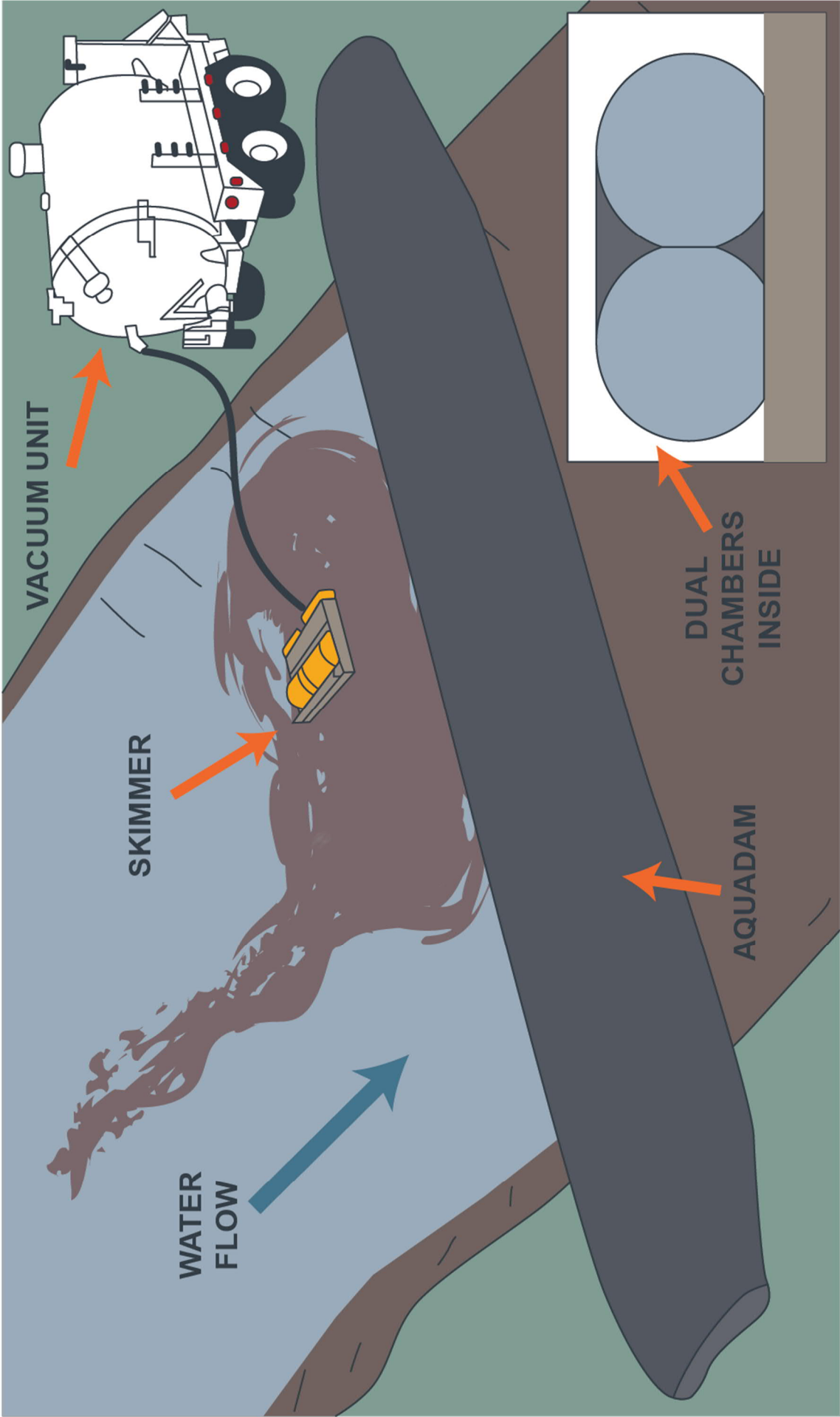

**AQUADAM**

# CULVERT BLOCK



Culverts that allow a watercourse to pass under or through obstacles present an opportunity for controlling the spread of oil. If water flows are sufficiently low, they can be blocked entirely with boards or plywood to contain oil above the culvert. In higher flow situations, partial culvert blocks can be installed to create underflow dams.

## Objectives

- ◇ Contain and prevent further migration of released products using sandbags / plywood.
- ◇ Create pooled area to allow recover of released product.



## Safety

- ◇ Identify hazards and complete a site safety plan.
- ◇ Consider toxic and flammable vapours.
- ◇ Adjacent infrastructure such as powerlines, pipelines, and underground services.
- ◇ Establish communications in remote areas.



## Environmental Consideration

- ◇ Utilize existing access and routes to minimize disturbance of soils. Consider environmental sensitivities such as vegetation soil types and wildlife/fish habitat.
- ◇ Ensure decontamination areas have been established to minimize transfer of released product during site assessment and site preparation activities.
- ◇ Consider air quality issues and proximity of stakeholders.
- ◇ Manage board level to allow water to pass through culvert, reducing flooding upstream and maintain downstream flow.



## Equipment / Resources

- ◇ Track hoe
- ◇ Sorbents
- ◇ Shovels
- ◇ Earthen materials or sandbags
- ◇ Vacuum truck / portable vacuum unit
- ◇ Skimmer
- ◇ Temporary storage
- ◇ Plywood, stakes, nails



## Procedure

- ◇ Using earthen materials or sandbags, completely block the culvert or,
- ◇ Using plywood on upstream side of culvert. Secure in place with two stakes driven into bed of ditch, creek or stream. Raise board enough to allow passage of water under the board's lower edge. Secure in place with driving nails through stakes into the plywood.
- ◇ Monitor water levels to ensure sufficient flow and to prevent washouts.
- ◇ Utilize vacuum unit or skimmer to recover pooled fluids and dispose at appropriate location.
- ◇ Utilize containment boom to protect banks from oil impacts.



## Personnel

- ◇ Track hoe operator
- ◇ Vacuum operator
- ◇ Supervisor / lead
- ◇ Site safety
- ◇ Labourers



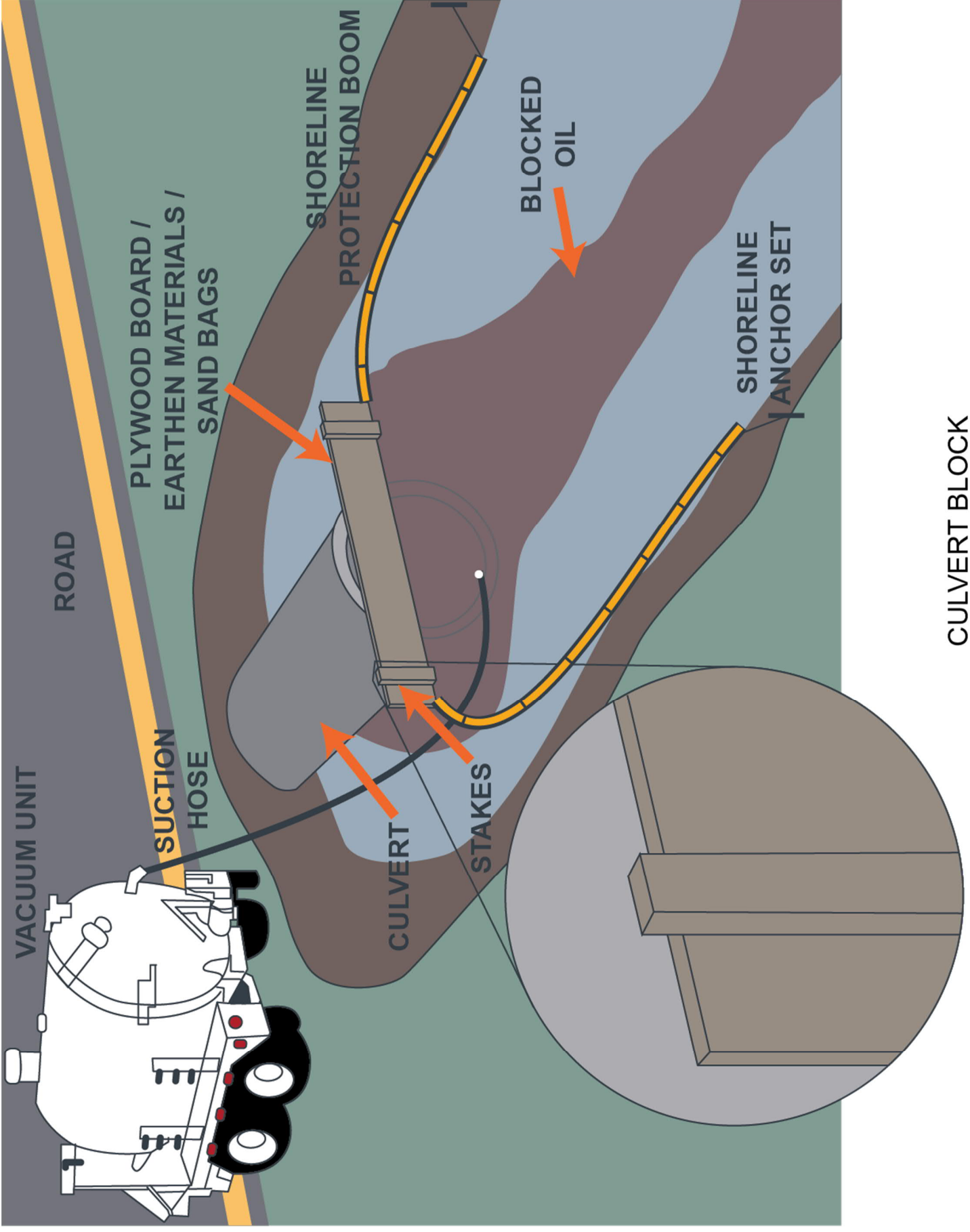

# BOOM DEPLOYMENT



Larger watercourses are those where any combination of water depth, river or stream width, or current velocity would make the installation of bottom-founded or rigid fixtures impractical. The tactics that follow rely on the installation of flexible, floating barriers to redirect or divert surface contaminants.

## Objectives

- ◇ Divert surface contaminants from sensitive resources.
- ◇ Divert surface contaminants to areas of quiet water where velocities are slower and contaminants may be collected.



## Floating Containment Boom

- ◇ Identified by the overall height of the boom or by the diameter of the float and the depth of the skirt.
- ◇ Shallow skirts are advised for fast moving waters, because their reduced drag makes them easier to deploy and secure. Deeper skirts are advised where waves may be encountered.

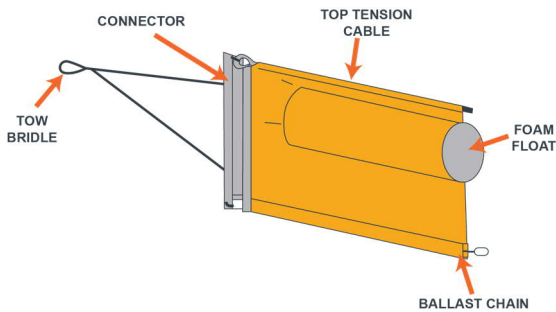

Boom Property	Static Water	Moving Water
Overall height (in)	6 - 24	8 - 32
Minimum gross buoyancy to weight ratio	3:1	4:1
Minimum total tensile strength (lbs)	1,500	5,000

75°	60°	45°	30°	15°
1.4 kph	1.6 kph	2.0 kph	2.8 kph	5.4 kph
0.9 mph	1.0 mph	1.2 mph	1.7 mph	3.3 mph

## Shore Seal Boom

- ◇ Provides an effective barrier to control the spread of oil in the critical region where water meets the shoreline.
- ◇ A floating barrier with integral water bags that provide an effective seal when grounded.
- ◇ A smaller tube is fitted into a larger tube. The larger outer tube is filled with water and the smaller inner tube is filled with air.
- ◇ Shore seal boom can adjust to fluctuating water levels.

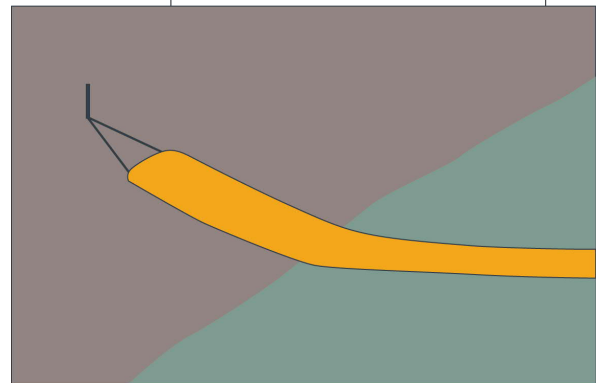
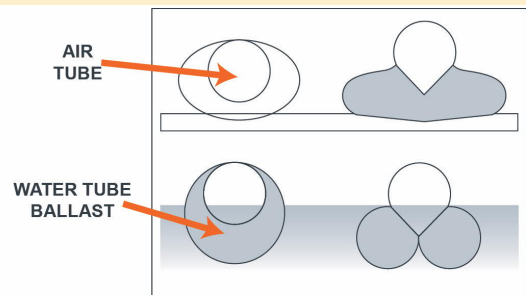

15°
5.4 kph
3.3 mph

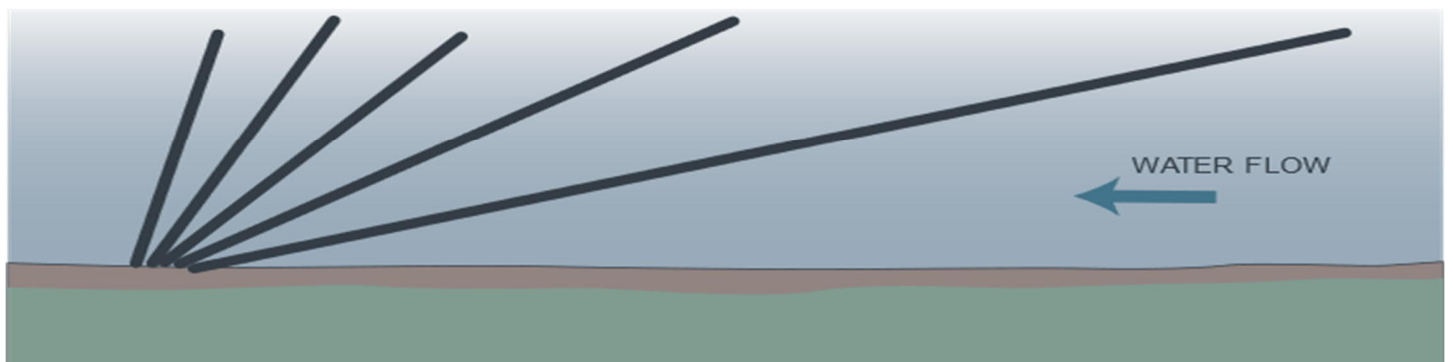

Time in seconds stick travels 30 m (100 ft)	Current km/hr	Current mph	Current (metres per second)	Current (feet per second)	Boom angle (degrees to current)
216 108 72 54	0.5 1.0 1.5 2.0	0.31 0.62 0.93 1.25	0.14 0.28 0.42 0.56	0.46 0.92 1.38 1.84	30 degrees
43 36 31 27	2.5 3.0 3.5 4.0	1.5 1.9 2.2 2.5	0.69 0.83 0.97 1.11	2.26 2.72 3.18 3.60	20 degrees
24 22 18	4.5 5.0 6.0	2.8 3.1 3.7	1.25 1.39 1.67	4.10 4.56 5.48	15 degrees
15 14 12 11	7.0 8.0 9.0 10.0	4.3 5.0 5.6 6.2	1.94 2.22 2.50 2.78	6.36 7.28 8.20 9.12	10 degrees

## Considerations

When determining the type of containment operation to be utilized on a watercourse, the following should be considered:

- ◇ The slower the current and deeper the water, the more effective the containment and recovery operations will be.
- ◇ Chose a location where the current is directed towards the recovery area.
- ◇ Consider access and staging when selecting a recovery location.
- ◇ On larger watercourses chose a location that is on the side as the spill.
- ◇ Boom should be a straight as possible to defect oil to recovery areas.
- ◇ Boom angle is critical for ongoing maintenance of containment and recovery operations.
- ◇ In faster moving water, consider additional containment boom downstream to capture any flow through.
- ◇ If not feasible to boom entire channel, select as site that will capture most of the released product and consider further downstream containment and recovery areas.
- ◇ Select boom anchoring methods considering the following:
  - ◇ Shoreline Pins can be used on narrow slow-moving watercourses and installed along the banks and include drive pin, screw, wing pin anchors, trees, or large rocks.
  - ◇ Trolley Line can be deployed across large, moderate to fast moving watercourses and can be used with split pulley to deploy and adjust the boom angle.
  - ◇ Bridge Pier Bridle can be installed on large, moderate to fast moving watercourse with the use of workboats
  - ◇ In-Stream anchors and chain sets can be deployed within the watercourse by workboat crews and include sarca, danforth and rake anchors.
  - ◇ Boom Vane can be deployed from shore and utilizes the instream current and mooring lines to set boom angles.



# SKIMMERS, VACUUM UNITS, TEMPORARY STORAGE



Recovery will involve the use of equipment as determined by plans and the scope of the incident.

## Skimmers

- ◊ Selective skimmers rely on oleophilic material that can be passed through the oil-interface. Selective skimmers collect a higher concentration of oil in the recovered fluid stream than non-selective skimmers.
- ◊ Non-selective skimmers are usually weir or suction devices that recover fluid indiscriminately.

Skimmer Type	Oil Type	Mode	Debris Tolerance	Wave Tolerance	Currents
Drum (selective)	Wide range of oil viscosities	Stationary	Debris must be managed to allow flow of oil to skimmer	Low sensitivity to waves with height less than diameter of drum	Not generally used in currents
Disc (selective)	Low to medium viscosity	Stationary	Debris must be managed to allow flow of oil to skimmer	Low sensitivity to waves with height less than diameter of disc	Not generally used in currents
Brush (selective)	Medium to high viscosity	May be operated in stationary mode if current is present	Effective in most forms of small debris	Low sensitivity to waves	May be operated in stationary mode if current is present
Pedco (non-selective)	Wide range of oil viscosities	Stationary	Debris must be managed to allow flow of oil to skimmer	Low sensitivity to waves	Used in currents typically river, streams and creeks
Circus (non-selective)	Wide range of oil viscosities	Stationary and advancing	Debris must be managed to allow flow of oil to skimmer	Good wave-following characteristics in nonbreaking waves	Used in currents typically river, streams and creeks
Broad Suction (non-selective)	Wide range of oil viscosities	Powered by vacuum or pump	Works around debris	Low sensitivity to waves	Static water conditions

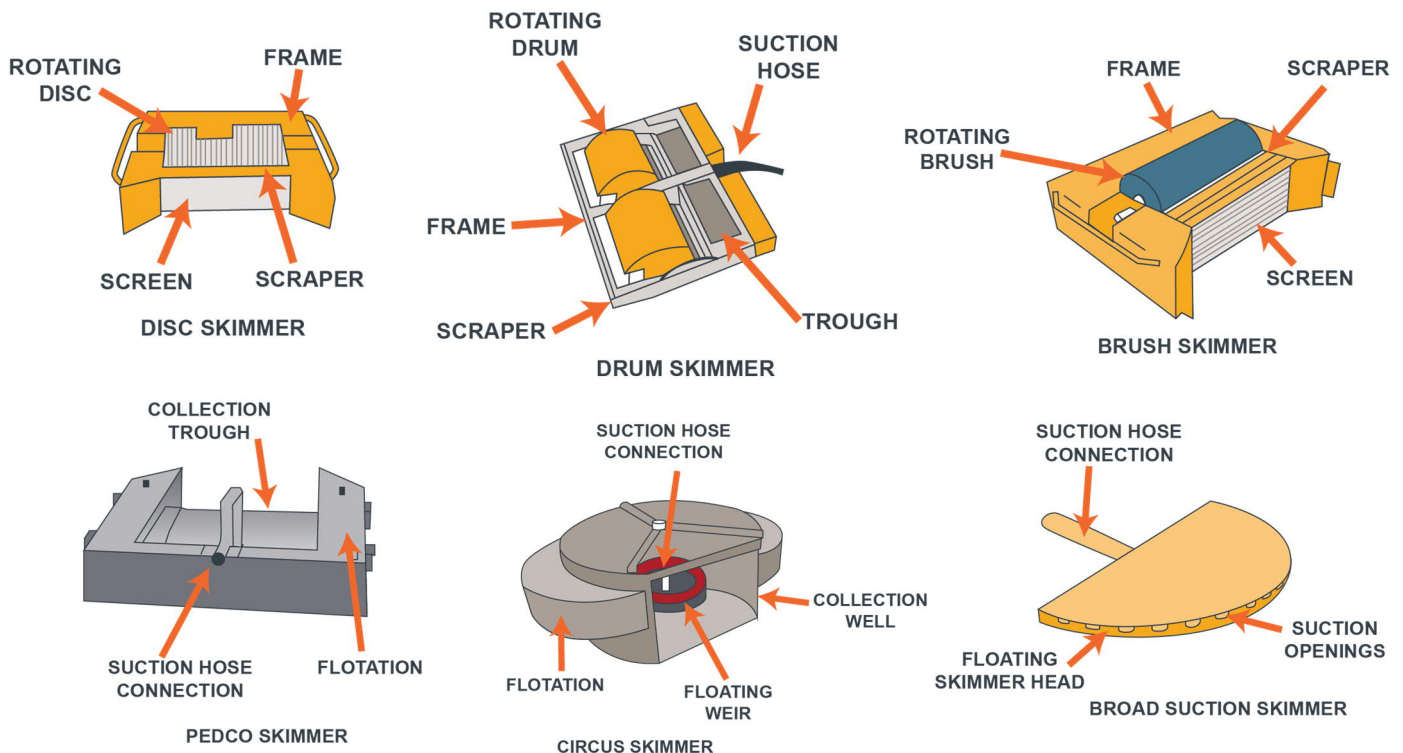

# Vacuum Units

- ◇ Operate on the same principle as an industrial vacuum cleaner
- ◇ A suction pump pulls large quantities of air through a hose and into a large-volume receptacle. The sudden velocity drop that occurs in the receptacle causes liquids and solids to fall out of the airstream and collect. This process may be aided by internal baffles in the receptacle.
- ◇ May be used in place of pumps to operate pedco or broad suction skimmers or to transfer collected oil from disc or drum skimmers.

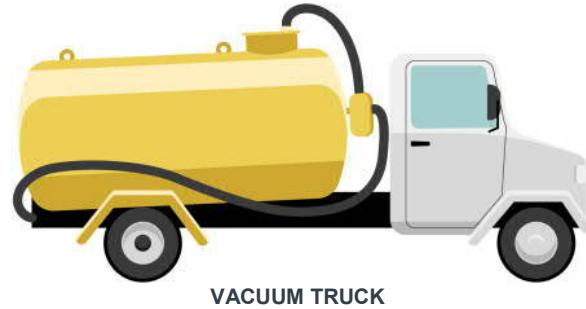
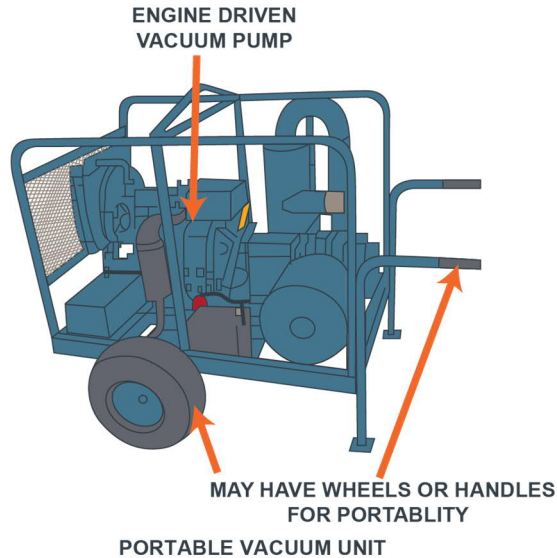

# Temporary Storage

- ◇ Recovered oil can be critical to the success of a spill response. Temporary storage tanks are usually fabric, for storage and portability.
- ◇ Depending on the type, they may or may not have a rigid frame
- ◇ Note that open storage devices do not have positive vapor control. Hence, they may not be suitable for storage of highly volatile products.

Storage Type	Vapor Control	Capacity	Storage Length
Pillow Tank	Yes	750 - 19,000 L	Temporary and long-term
Open Storage - Rigid Frame	No	900 - 75,000 L	Temporary
Open Storage - Frameless	No	750 - 19,000 L	Temporary

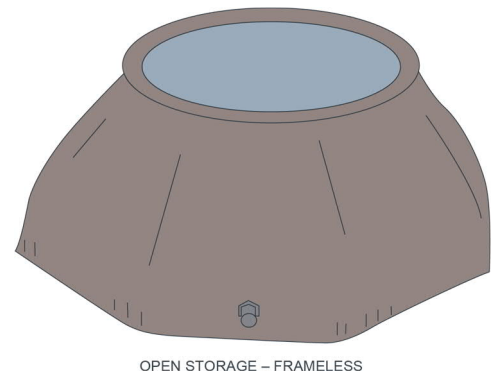
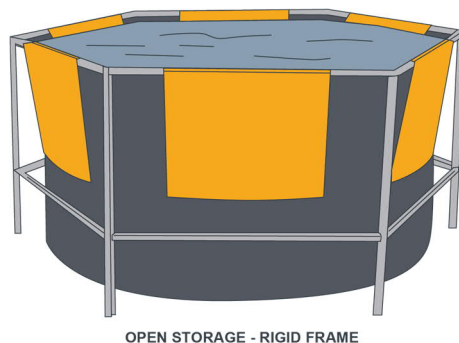
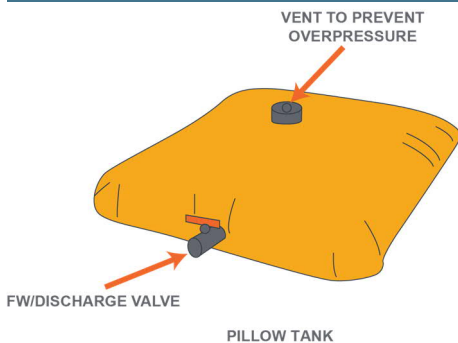

## Post-Incident

Ensure all statements, event logs, forms and documentation on the incident remain securely stored following the incident. Records must be held for a minimum of 5 years as it may be requested by the regulatory agency at any point during that time.

## Call Down Notification

After consultation with a senior company representative or the appropriate Regulatory Agency, Provincial Emergency Management or local County / Municipality, the Incident Commander will:

1. Give the "all clear" signal. Prior to the "all-clear" signal, the Incident Commander will confirm that all evacuated areas are safe to re-enter. This may involve such activities as:
  - Ensuring all equipment and locations are free of any pockets of fire, smoke and / or toxic gases.
  - Ensuring all equipment and debris are removed from offices and / or public areas.
  - Cordoning off the incident area to isolate any remaining hazards.
  - Checking low-lying areas and basements for contamination, if a toxic leak has occurred.

After the "all-clear" message has been given, the Incident Commander will be responsible for:

- Ensuring all evacuees are promptly notified once the call down is given.
  - Coordinating the return of any evacuees to the area. Ensure the public and employees receive any assistance they may require.
  - Maintaining security in any evacuated areas until the evacuees have returned and the businesses in the area have again become occupied.
2. Coordinate the deactivation of all emergency response operations, personnel, equipment and incident areas.
  3. Ensure all previous contacts, including other companies; government agencies, etc. are notified of the emergency status call down.
  4. Advise all response team members to document their call down notification calls.
  5. Prepare and release an "all clear" statement to the media in conjunction with the Regulatory Agency.
  6. Organize debriefing meetings for advisory personnel involved. In the case of incidents that have involved a death or serious injury, consult with Human Resources personnel about arranging critical incident counselling.
  7. Notify and debrief Joint Interest Partners and Insurance company representatives.

*Note: Ensure all statements, event logs, forms and documentation on the incident remain securely stored following the incident.*

## Public Care and Assistance

The decision to recall evacuees will be coordinated by the regulatory agency in consultation with other applicable government agencies and the licensee. Ensure the following tasks are completed as required:

1. Ensure all evacuees are promptly notified once the call down is given.
2. Coordinate the return of any evacuees to the area. Ensure the public and employees receive any assistance they may require.
3. Maintain security in any evacuated areas until the evacuees have returned and the businesses in the area have again become occupied.
4. Ensure homes and businesses are ventilated and checked for gas pockets before allowing the occupants to enter. Rovers must check each room, office and public area.

## Post-Incident, continued

5. Ensure members of the Response Teams and other key participants in the emergency are debriefed as soon as possible.
6. Designate a senior company representative to act as the company Liaison with the public and other companies.
7. Ensure the affected employees and public are provided with post-incident company contact names and telephone numbers. If the emergency has impacted a large number of the public or has caused significant damage to private property or the environment, a temporary Public Relations Office should be established in the affected area.
8. Schedule a follow-up meeting with the public to clearly explain the cause of the incident and to address their concerns. Organize critical incident counselling as required.
9. Ensure public expense / damage claims have been collected and are processed in a timely manner.

## Clean-up and Repair

If a serious injury or death has occurred, the scene must be left undisturbed, as much as possible, until an investigation of the site can be completed by the appropriate authorities.

Ensure the following tasks are completed as required:

- Ensure the incident site is not disturbed if there has been a fatality or a serious injury until police, regulatory officials and company representatives complete necessary investigations.
- Ensure that site clean-up continues.
- Ensure that the correct procedures are developed and implemented for the decontamination of equipment.
- Ensure the On-Site Group Supervisor disposes of all hazardous waste according to applicable regulations (confer with the safety support personnel, the Response Team or other company safety personnel).

Note: The position of On-Site Group Supervisor during the remediation phase may be best filled by an Environmental Specialist.

- Ensure that priority is given to clearing debris and restoring the site to normal operating conditions after the government and company investigations are complete.
- Ensure that all safety equipment is demobilized, cleaned and inspected for contamination.
- Ensure all roadblocks, staging area and detour equipment is demobilized.
- Ensure that all clean-up and repair actions follow the companies safety and environment policies and safe-work procedures.

## Third Party Investigations

The Incident Commander will coordinate and observe all site investigations. Third party investigators such as police, government agencies and insurance companies may be required to investigate an incident site. It is important to co-operate with third party investigators. However, company personnel should be aware of the corresponding corporate guidelines.

- Obtain the name, title, address and telephone number of all inspectors and immediately inform the Incident Commander before proceeding with the investigation.

## Post-Incident, continued

- Ensure a company representative accompanies the inspector at all times. Never leave an inspector unattended.
- Give the inspectors the information they request, the facts only, no speculative information. Always tell the truth.

Document all items of evidence that the inspector has retained. Where possible, keep copies of the evidence provided to the Inspectors.

Wait until legal counsel is present before answering questions where the inspector indicates that any statements may be used as evidence or indicates that you have the right to counsel.

## Review and Debriefing

The effectiveness of the ERP shall be reviewed after the end of the emergency. In some situations, a formal debriefing may be held. The objective of the debriefing should be to improve emergency preparedness and response by identifying areas of success and areas requiring improvement (a debriefing should not be a fault-finding mission). If one is held, all groups that responded to the emergency should be represented. The representatives should come prepared with complete details of their activities during the emergency and, where possible, provide supporting documentation. Common elements of an effective debriefing include:

- a) A facilitator;
- b) A secretary to record the proceedings;
- c) A review of the sequence of events, including timing and actions taken; and
- d) Identification of those portions of the ERP that were effective and those that require improvement.

Action items identified during the debriefing should be documented and assigned with completion timelines, key lessons learned from emergency outcome should be shared with the appropriate parties, and the ERP should be revised as necessary. Separate debriefings may be held with different groups that participated in the emergency (e.g., emergency services organizations, the media, etc.).

## Critical Incident Stress Debriefing (CISD)

Responders are often under a great deal of stress. They must act quickly, often in the face of pain and fear, to assess the situation, determine priorities and begin rescuing others who are in danger. They may have experienced a serious injury themselves or witnessed the death of co-workers or the public.

If necessary, the Incident Commander will request that the company's Human Resource personnel dispatch specially trained counselors to meet with responders, preferably within 24 to 48 hours, to provide support and reassurance to those affected by an emergency. Team members should include a mental health professional and trained peer support personnel (fire-fighters, paramedics, police, military, etc.).

CISDs allow individuals to express the circumstances they were confronted with, how they felt at the incident and what their reactions were after the incident. The participants must understand that the meetings are strictly confidential and are not intended to judge or lay blame on an individual's actions. Recording devices and note taking should be prohibited. Meetings should be limited to a maximum of 20 individuals. Individuals who are perceived to be responsible for the incident should be excluded from group meetings and met on a one-on-one basis.

These sessions provide the responders with a supportive environment that helps them deal with their emotions. It also provides them with information about stress and its effects (severe agitation, emotional upset, inability to sleep, etc.) and it educates them about stress management techniques.

## Post-Incident, continued

### Post-Incident / Accident Investigation

Once the emergency status has been removed, a senior company representative will appoint a subcommittee to investigate the event. This subcommittee will consist of appropriate management and technical specialists as required.

The objective of the investigation will be to analyze and evaluate the event in order to establish a cause, to provide advice on how to prevent a reoccurrence of the event, and to make recommendations on procedures that will improve the company's emergency response efforts in the future.

The post-incident / accident investigation should include:

- A review of the events leading up to the incident / accident.
- An analysis of the on-site remedial procedures, including an evaluation of the safety standards that were applied.
- An appraisal of the company's shelter-in-place / evacuation response for the affected public.
- An evaluation of the effectiveness of the notification and communication systems between the incident site and the head office, as well as within the company.
- An appraisal of the effectiveness of any media or public relations efforts.
- An assessment of any potential legal or environmental issues that may be raised as a result of the event or as a result of the company's response efforts.
- A summary of current and future costs.
- Completed appropriate event report forms and applicable attachments.
- An assessment of the strengths and weaknesses of the company's response.

This report will be directed to the attention of a senior company representative. It will be his / her responsibility to ensure all recommendations for improvements to the Corporate and Field Emergency Response Plans are incorporated where applicable and promptly communicated to the appropriate company personnel.

Within 30 days of the end of an incident, a Licensee must file with the Provincial Agency, National Energy Board (NEB), and / or the Transportation Safety Board (TSB), an Operator Incident Summary Report structured as outlined by the Provincial / Federal Agency. After reviewing the Operator Incident Summary Report, the Provincial and / or Federal agency may require that the licensee attend a meeting to further discuss the incident.

All documentation recorded during and following an emergency must be retained for up to five years in the event the Regulatory Agency requests it.

## Medical Emergencies

DISCLAIMER: The information contained in this section does not replace formal First Aid, CPR & AED training. The company makes no guarantee as to, and assumes no responsibility for, the correctness, sufficiency or completeness of such information or recommendations. A First Aid provider is someone who has completed formal first aid training from a recognized provider. Training can be obtained from the Canadian Red Cross ([www.redcross.ca](http://www.redcross.ca)) or St. John Ambulance ([www.sja.ca](http://www.sja.ca)).

The 3 basic steps to follow in any emergency:

**Remember: stay calm, look for dangers, never risk your own safety**

### CHECK the person

- Does the person want your help? If the person is unable to answer, assume you have consent to give first aid.
- Check the person's ABCs (Airway, Breathing, and Circulation).



### CALL EMS/9-1-1

- If the person responds, find out if there is a need to call EMS/9-1-1.
- If the person does not respond, call for help and EMS/9-1-1.



### CARE for life-threatening conditions first

- Reduce the risk of disease transmission by using protective equipment, such as disposable gloves and a barrier device.



Canadian Red Cross (2013). Check, Call, Care First Aid Poster. Retrieved February 2013, from Canadian Red Cross Web site: [http://www.redcross.ca/cmslib/general/tp\\_fa\\_poster\\_checkcallcare\\_web.pdf](http://www.redcross.ca/cmslib/general/tp_fa_poster_checkcallcare_web.pdf)

## Medical Emergencies, continued

### First Aid Information

#### CPR

The simplified Adult Basic Life Support algorithm includes five steps. The algorithm diagram provided by the American Heart Association emphasizes the following:

1. Assess the victim's responsiveness. If a victim is not breathing, or is not breathing normally (i.e., gasping), initiate CPR. Health care professionals should be trained to recognize cardiac arrest that presents as seizure-like activity or with agonal respirations.
2. Activate EMS (Emergency Medical Response) by calling 911.
3. Retrieve a defibrillator, usually an automatic external defibrillator (AED).
4. The algorithm proceeds in a loop of CPR and rhythm checks with defibrillation.
5. Check PULSE before chest compressions for at least five seconds and no more than ten seconds. If in doubt, begin compressions
6. CPR: push hard and fast. Begin chest compressions before ventilation. Chest compressions allow blood flow to the heart and brain. Delays in chest compressions result in diminished survival. Be sure to allow the chest to recoil between compressions. The chest should be compressed 100-120/min to a depth of 2"-2.4" (5-6cm)
7. For effective breathing, watch for chest rise and avoid excessive ventilation. 10 BREATHS should be delivered each minute, or one breath every six seconds. Each breath should be delivered over 1 second. Observe visible chest rise.
8. Avoid gastric inflation, as it may result in aspiration, pneumonia or vomiting.
9. The ratio of chest compressions to breaths is 30 to 2.
10. After the defibrillator becomes available, check rhythm. Use the AED when indicated and available. The victim should receive a shock that is repeated every two minutes or 5 cycles.

#### Burns

The American Red Cross recommends these steps to care for minor burns.

- Stop the burning. Put out the flames or remove the victim from the source of the burn.
- Cool the burn. Use large amounts of water to cool the burned area. DO NOT use ice or ice water other than on small superficial burns. Ice causes body heat loss. Use whatever resources are available: tub, shower or garden hose. You can apply soaked towels, sheets or other wet cloths to a burned face or other areas that cannot be immersed. Be sure to keep cloths cool by adding more water.
- Cover the burn. Use dry, sterile dressings or a clean cloth to cover a burn. Loosely bandage them in place. Covering the burn helps keep air out and reduces pain. Covering the burn also prevents infection. If the burn covers a large area of the body, cover it with clean, dry sheets or other cloth.

For minor burns and burns with open blisters that are not serious enough to need medical care, wash the areas with soap and water. Keep it clean. Put on an antibiotic ointment. Watch for signals of infection.

---

## Medical Emergencies, continued

### Burns, continued

Critical burns will need immediate medical attention. Call 911 or your emergency number if any one of the following instances occurs:

- Victim is having difficulty breathing.
- More than one part of the body is burned.
- There are burns to the head, neck, hands, feet or genitals.
- A child or an elderly person has been burned.
- Chemicals, electricity or explosions have caused the burns.

### Chemical Exposure Guidelines

- In the event of chemical exposure, emergency services or poison control centre should be contacted as soon as possible.
- The eye may be irrigated using copious amounts of clean water, preferably using an eyewash bottle, eyewash station or shower.
- First aid providers may use continuous, large volumes of clean water for irrigation of chemical injuries where chemical exposure has occurred to other parts of the body.

### Wounds & Abrasions Guidelines

- Superficial wounds and abrasions should be irrigated with clean water, preferably tap water because of the benefit of pressure.
- First aid providers may apply antibiotic ointment to skin abrasions and wounds to promote faster healing with less risk of infection.
- First aid providers may apply an occlusive dressing to wounds and abrasions with or without antibiotic ointment.
- The use of triple antibiotic ointment may be preferable to double- or singleagent antibiotic ointment or cream.
- If antibiotic is not used, antiseptic could be used.
- There is some evidence that traditional approaches, including applying honey, are beneficial and may be used on wounds by first aid providers.
- People with wounds that develop redness, warmth or become painful or with wounds where the person develops fever should seek assessment from a healthcare provider.

## Medical Emergencies, continued

### Bleeding Guidelines

- First aid providers must control external bleeding by applying direct pressure.
- The use of pressure points and elevation is NOT recommended.
- When direct pressure fails to control life-threatening external limb bleeding or is not possible (e.g. multiple injuries, inaccessible wounds, multiple casualties), tourniquets could be considered in special circumstances (such as disaster, war-like conditions, remote locations or in instances where specially trained first aid providers are providing care).
- Localized cold therapy with or without pressure may be beneficial in haemostasis for closed bleeding in extremities. Caution is advised when applying this recommendation to children due to a potential for hypothermia.
- The out-of-hospital application of a topical haemostatic agent to control lifethreatening bleeding not controlled by standard techniques and in situations where standard techniques could not be applied could be considered with appropriate training.

Source: [www.redcross.ca/crc/documents/1303501\\_FirstAid-2016\\_Guidelines\\_LR-PDF.pdf](http://www.redcross.ca/crc/documents/1303501_FirstAid-2016_Guidelines_LR-PDF.pdf)

## Medical Emergencies, continued

### Next-of-Kin Notification

When an employee, contractor or member of the public is seriously injured, missing, or pronounced dead, the next-of-kin must be notified as promptly as possible. Keep in mind the following policies before notifying any next-of-kin:

- Death is never presumed, and first aid must be administered until relieved by a paramedic.
- No telephone or radio discussion is to take place regarding the name(s) of the injured.
- Notification is not to occur until the casualty has been pronounced dead by a medical doctor or medical examiner.

If an employee, contractor or member of the public is injured or killed as a result of company operations; notifications will be coordinated through local RCMP / municipal police and designated company personnel.

### Before Notifying the Next-of-Kin

- Never release the names of the injured, missing, or persons pronounced dead before the next-of-kin are notified.
- Triple-check the identity of any casualty.
- If the casualty is conscious, document concerns. Do not make promises that cannot be kept.
- Confirm the casualty's relationship with the people being notified.
- Be prepared to support the next-of-kin. Provide assistance such as transportation, child care, alternative accommodation, reimbursements for daily expenses, and the temporary care of the family home if required.

### During the Notification of the Next-of-Kin

- Make the notification in person, not by telephone or through an intermediary.
- Provide the relatives with as much information as possible; too few details can cause excessive worry. Present only the facts; do not speculate.
- Do not discuss personal views of liability or fault.
- Allow the next-of-kin to vent their emotions.
- Attempt to support and reunite families as quickly as possible.
- Offer assistance; document key issues and concerns. Do not make promises that cannot be kept. Follow up on relatives' requests.
- Document the details of anyone who appears to be having trouble coping with the incident so that he / she can be given prompt psychological support.

---

## Medical Emergencies, continued

### During the Notification of the Next-of-Kin, continued

- Do not leave the next-of-kin alone.
- Offer to contact a neighbour, friend, relative, minister, doctor, or counsellor.
- Leave your name and telephone number with family members.
- Ensure the next-of-kin are protected from media harassment as required.

### Follow-Up

- The same representative who conducted the initial notification should continue to contact and support the next-of-kin.
- If required, a senior company representative will ensure that a trained psychologist conducts critical incident stress debriefing sessions with next-of-kin, friends and company employees involved or affected by the tragedy.
- Advise the employee's family that a senior company representative will be contacting them to discuss any immediate needs and to provide information on insurance coverage and benefits support. Follow up on this commitment.

# Medical Evacuation (MEDEVAC) Procedure

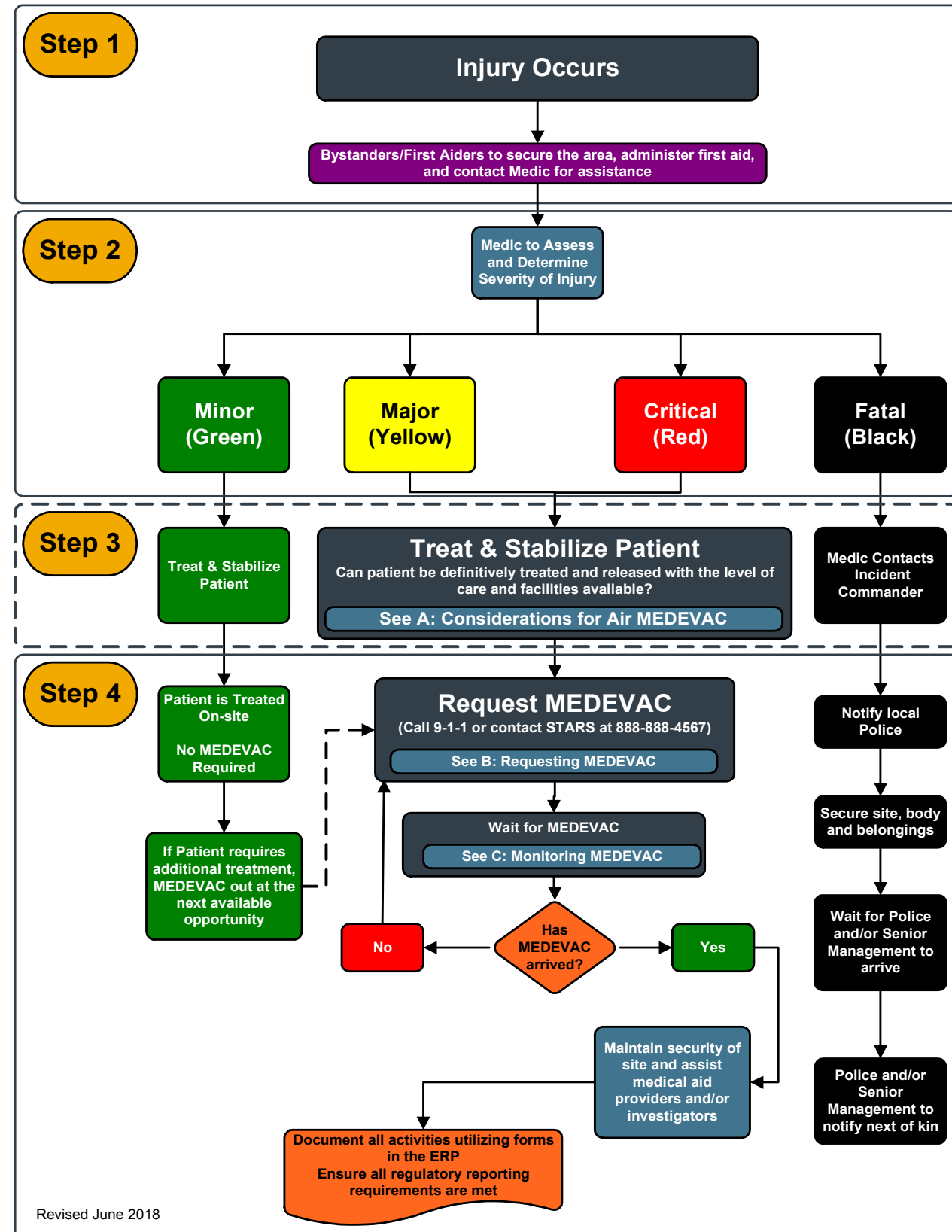

**In the event of any injury or illness the following steps shall be followed:**

**1) Survey the scene and ask yourself the following questions:**

- Is it safe for me to help?
- What happened?
- How many people are injured?

**2) Call for help:**

- 1) Activate Emergency Responders and/or call 9-1-1
- 2) Identify your location
- 3) Follow the direction of the Medic and administer First Aid if required and you are trained to do so
- 4) Review Step 1

**Patient Priority Colour Code**

The practice of colour coding patients is a useful tool to prioritize patients into categories depending on their medical condition. This colour code system allows ease of communicating the condition of the patient to those involved in the care and transportation of the patient.

**Green** – Patients with minor injuries or illnesses who are usually walking. Medical care can be delayed beyond 2 hours.

**For example:**

- Minor burns
- Sprains and strains
- Colds and flu symptoms

**Yellow** – Patients with major injuries or illnesses that should be treated within 20 minutes to 2 hours.

**For example:**

- Open fractures
- Large lacerations

**Red** – Patients with critical, life threatening injuries or illnesses that require treatment as soon as possible.

**For example:**

- Airway problems
- Severe hemorrhage
- Severe burns
- Failing vital signs

**Black** – Death is obvious. Note: resuscitation / treatment must continue until directed otherwise by a qualified medical provider. Await Police.

**A: Considerations for Air MEDEVAC**

Consider air transport when:

- Patient requires critical care life support during transport that is not available locally.
- Patient's condition requires that time spent in transport be as short as possible.
- Potential delays associated with ground transport (road obstacles or conditions, traffic, distance) are likely to worsen the patient's condition.
- Patient is located in an area inaccessible to regular ground transport.
- The use of medical transportation resources would leave the local area or worksite without adequate medical coverage.

**B: Requesting MEDEVAC**

When requesting MEDEVAC, be prepared to supply the following information:

- Location of patient pickup (facility, airport, road intersection, GPS)?
- Who will be meeting MEDEVAC crew (radio callsign / frequency, cell number)?
- Will the patient meet the MEDEVAC crew at the pickup location or will the MEDEVAC crew need to be transported to the patient?
- Any special equipment required (ventilator, bariatric transport equipment, etc.)?
- Will any additional personnel be necessary (physician, nurse)?
- Is there an intended destination (major hospital, community)?
- Has any consultation with medical providers at the intended destination been done?

Do not delay launch / dispatch of MEDEVAC, provide the following information once available:

- Mechanism of injury (and time of injury if known)
- Injury or illness sustained
- Symptoms and vital signs
- Treatment given

**C: Monitoring MEDEVAC**

When requesting MEDEVAC, ensure that you are monitoring the transport and are aware of who to contact for updates and in case changes to plan are required.

When is MEDEVAC transport scheduled to arrive?: \_\_\_\_\_

What number should be contacted if something in the plan needs to be changed? \_\_\_\_\_

If transport doesn't arrive, or if no updates are heard, what time will we contact MEDEVAC for an update? \_\_\_\_\_

**Emergency MEDEVAC Phone Numbers**

**PROVINCIAL AIR AMBULANCE:**

Alberta	800-661-3822
British Columbia	911
Manitoba	800-689-6559
Saskatchewan	888-782-8247

**STARS (AB, BC, SK, MB):**  
24 Hour Emergency: 888-888-4567

Revised June 2018

Note: When a medical evacuation is complete all personnel must report to the Incident Commander for a debriefing session.

This page is intentionally left blank

## Responder Safety

### Site Safety

Response personnel must stay out of the hazard area until the hazards are identified and assessed. All responders must evaluate potential site hazards including ignition sources or vapours gathering in low-lying areas such as ditches, trenches, and forested areas. The nature of a hazard will influence the responses. Therefore, the following characteristics about the hazard **must** be considered:

- The quantity and type of product involved.
- The potential for the situation to escalate.
- The location of the incident, the time of day and the weather conditions.
- Actual and perceived danger to responders, the public and the environment.
- The number of responders and their training.
- The availability of response equipment.
- The availability of external support, e.g. ambulances, police, fire fighters and mutual aid.

Responders **must** approach an incident site that may have gases or explosive vapours from an upwind or crosswind direction. They should inspect the site from a distance (using binoculars if possible) if hazards have not been assessed. When on-site, responders must take the following precautions:

- Identify safe escape routes away from hazardous areas.
- Continue to assess the related hazards, e.g. toxic vapours, fire or explosion hazards.
- Protect themselves and others (responders and public) before initiating control and containment operations.
- Do not allow anyone, including first responders such as police, fire fighters or ambulance attendants to enter the hazard area unless they are properly trained and equipped with personal protective equipment.
- Avoid extinguishing an ignited hydrocarbon release if the supply cannot be stopped.
- Only attempt fire control on small fires. Extensive fires or uncontrolled facility fires must be dealt with by external firefighting professionals. Responders must not attempt to battle a fire without adequate firefighting equipment, training, and backup personnel.
- Advise fire authorities when a company facility is threatened by an external fire. They should also be made aware of dangerous products or flammable hazards at the facility, such as pressurized NGL vessels, chemical and fuel storage.

Consider an outside expert when necessary. Well control, for example, is a specialty requiring specific experience, equipment, and procedures.

## Responder Safety, continued

### On-Site Work Areas

The On-Site Group Supervisor may choose to separate the site into three distinct areas to clearly identify the high-risk areas and to reduce the hazards to the on-site responders. The three areas could be defined as the safe area, the hazardous area, and the decontamination area.

#### Hazardous Area (Hot Zone)

Extreme caution and planning must be undertaken when entering the hazardous area. Access to and from the hazardous area will be controlled. Only personnel with appropriate personal protective equipment, training and an understanding of the specific response and control procedures will be allowed into the hazardous area. An example is confined space entry and rescue. Prior to entry into the hazardous area, all personnel should fully understand the goals, the method of on-site responder communication and the rescue plan.

The following guidelines help the On-Site Group Supervisor to determine the hazardous area. An area is considered hazardous if any of the following conditions exist:

- Combustible gas reading of 10% LEL or greater
- H<sub>2</sub>S gas reading of 10 ppm or greater (3-minute average)
- SO<sub>2</sub> readings of 5 ppm or greater (15-minute average)
- Oxygen content of less than 19.5% or greater than 23%
- Presence of organic and inorganic vapours / gases and liquids (consult Safety Data Sheets (SDS) for toxicity data)
- An area the On-Site Group Supervisor deems to be hazardous, such as the area surrounding a fire or spill

The On-Site Group Supervisor will consider the following on-site conditions when determining the size of the hazardous area:

- The location of access routes, power lines, pipelines, fire, and explosion hazards
- Areas where vapours are likely to accumulate such a downwind areas, low areas, confined spaces
- Site stability, e.g. steep slopes, overhanging banks, unstable soil, thin ice
- Weather conditions
- The toxicity and evacuation data for the product involved (Refer to SDS)

#### Decontamination Area (Warm Zone)

Personnel responding to hazardous substance emergencies may become contaminated in several ways:

- Contacting vapours, gases, mists, or particulate in the air.
- Being splashed by materials while sampling or opening a container.
- Walking through puddles of liquids or on contaminated soil.
- Using contaminated instruments or equipment.

## Responder Safety, continued

Decontamination is the complete or partial removal or neutralization of the harmful contamination chemicals. Some equipment will not withstand a proper decontamination process and therefore must be destroyed. Site safety personnel will recommend to the On-Site Group Supervisor whether clothing, instruments and equipment should be decontaminated or destroyed.

The decontamination area is usually set up in response to a hazardous material spill and when decontamination of personnel and equipment is required. The decontamination area buffers the designated hazardous and safe areas. Decontamination areas should be set up in areas that are not affected by the on-site hazard. Any contaminated personnel and equipment leaving the hazardous area must be decontaminated in the decontamination area before continuing to the safe area.

Equipment, solutions, and procedures required for decontamination depend on the type and degree of contamination. All hazardous waste must be disposed of according to applicable waste management regulations.

### Safe Area (Cold Zone)

The safe area is an area verified by the On-Site Group Supervisor to be safe. The On-site Command Post (OSCP) is located in the safe area. The safe area must be continually monitored and evaluated to confirm its safety. If there is any concern about the area's safety, the On-site Command Post will relocate to an area proven to be safe.

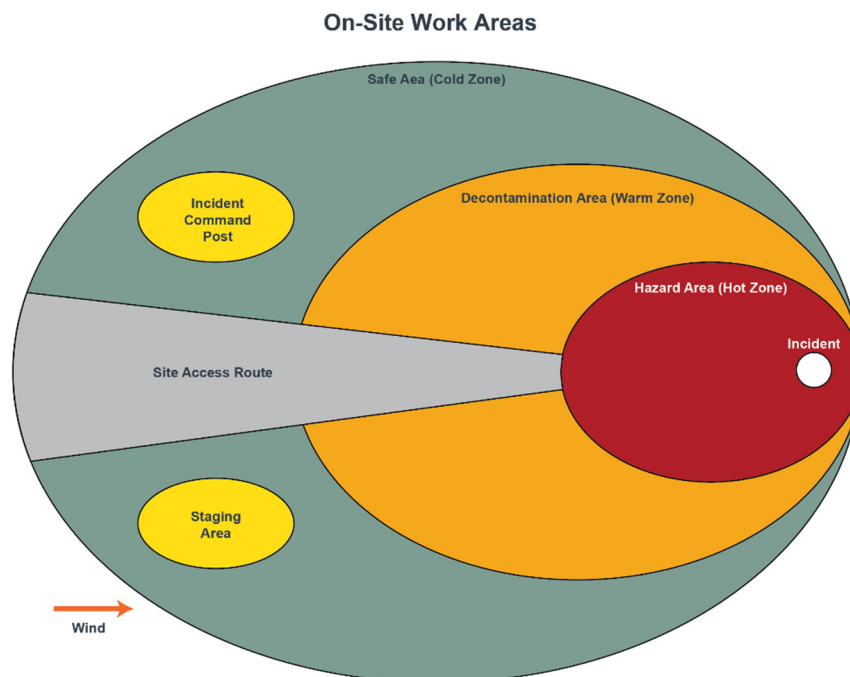

## Responder Safety, continued

### Working Alone

A Working Alone Procedure and a working alone hazard assessment are legislated responsibilities of every employer. One working alone hazard assessment may fit multiple work sites providing the working conditions are the same. These assessments must be available for the workers to review. All working alone hazards shall be mitigated to a reasonable and practical level of risk. Every worker who works alone must have a designated "Working Alone Contact". Activities, dates, and times of contact shall be documented and filed. The "Working Alone Contact" may be a co-worker, a 24/7 facility control room, a third-party emergency answering service, or automated working alone tracking system.

### Application

Each operating area will develop a Site-Specific Procedure (SSP) for Working Alone; the SSP will be documented, approved by management, and signed by every company employee or contract employee working in that operating area. Service suppliers will be expected to provide their own "Working Alone Programs" but due to communication limitations or emergency response capabilities they may need to utilize the company Working Alone Program, this temporary change of "Working Alone Contact" should be documented on the safe work permit.

### Potential Hazards

- Loss of communication needed for requesting assistance;
- Delays in reporting times;
- Injury requiring assistance; and
- Transportation problems.

### Equipment and Training Requirements

- The Working Alone Procedure and Response Plan for the overdue worker are to be a specific agenda item for safety meetings to ensure a suitable level of acceptance and involvement from all personnel is achieved, and
- Supervisors and members of the management shall discuss the plan with workers that participate in field activities, to ensure a high level of awareness and preparedness is maintained at all times.

### Low Risk Working Alone Procedure

(Sweet Gas Operations, daylight hours, normal weather conditions)

- The employee should notify their "Working Alone Contact" of check-in times and locations of work;
- If multiple travel routes are an option, then the route selected will also be noted
- If an employee's arrival at a check-in location is delayed by more than one (1) hour, the employee should notify their "Working Alone Contact" of the new estimated time of arrival.

---

## Responder Safety, continued

### High Risk Working Alone Procedure

(Sour Gas Operations, Call-outs, Adverse Weather Conditions)

- The employee should notify their "Working Alone Contact" prior to departure, and advise them contact of the estimated time of arrival at location;
- The employee should notify their "Working Alone Contact" of arrival at location;
- The employee should assess the problem or job scope, notify their contact, discuss the nature of the problem or job, work procedure to be used, and any additional required safeguards, and provide an estimation of how long they will be at the location;
- The employee should notify their "Working Alone Contact" when they are finished and ready to leave the location and estimated time of arrival at next check point, base or home; and
- The employee should notify their "Working Alone Contact" of arrival at next checkpoint, base or home.
- If the employee is delayed or expects to be delayed arriving at their next check-in point by more than one (1) hour, the employee should notify their "Working Alone Contact" of amended estimated time of arrival.
- During adverse weather conditions the employee should notify their "Working Alone Contact" of the exact route to be followed; shorter check-in time intervals are recommended.

Note: Every worker has both the right and responsibility to refuse unsafe work.

### Overdue Worker Response Plan

- The Overdue Worker Response Plan shall be initiated when a worker is one (1) hour overdue, (shorter grace periods may be instituted during bad weather or at high risk worksites), and
- After the one (1) hour grace period has expired, the worker's "Working Alone Contact" shall:
  - Attempt to contact the overdue worker by cell phone or radio; immediately notify the worker's supervisor of the circumstances;
- The supervisor will discuss options with the "Working Alone Contact" and together they will agree on an action plan; and
- The action plan may include any or all of the following:
  - Continue attempts to contact the overdue worker by cell phone or radio;
  - The "Working Alone Contact" or other designated individual will drive the route taken by the overdue worker in an attempt to contact the worker. Specific PPE safety equipment may be required for rescue activities by those involved with the Overdue Worker Response Plan;
  - The "Working Alone Contact" or the supervisor may request search assistance from industry workers in the area who have been identified in the contact list;
  - The "Working Alone Contact" or supervisor will call local hospital(s) to establish whether an injured person has been admitted; and
  - The "Working Alone Contact" or supervisor may notify the local police or RCMP of circumstances with a request for assistance.

## Responder Safety, continued

### Missing Persons

In the event that an employee should go missing:

- Confirm that the person has failed to check in at the predetermined time.
- Contact the person's supervisor (or next in line for reporting) and provide details, e.g. where the person was working, length of time overdue, and if the person is alone.
- If it is deemed appropriate to initiate a search, inform a supervisor (or next in line for reporting) of any plans before any employees head out to search.
- Employees should never endanger themselves during a rescue.
- Searchers should always use the buddy system and work in teams. Each team must be fully equipped, names logged, and their designated search area recorded on a map before heading out. Searchers should carry maps and compass, GPS (Global Positioning System) unit, survival kit, first aid kit, communication equipment, extra batteries, and appropriate provisions.
- Search first where the missing person will most likely be found, e.g. where the person's truck is parked.
- If the missing person is not found within a specified time (e.g. two hours), notify the appropriate Search and Rescue (SAR) authority and/or local police.
- When formal SAR groups are engaged, it is imperative that only one person coordinates all operations.
- Notify ALL authorities when the missing person is found so all search participants are informed and can cease their efforts.
- Complete and submit the required accident/incident investigation form.

*Source: PDAC Field Safety Pocket Guide*

### Rest Periods

Response members may experience a wide array of stresses which may include the death or serious injury of a co-worker, witnessing distressing sights, time pressures, responsibility overload, physical demands, mental demands, emotional demands, limited resources and high expectations from others, hazardous environments or extreme weather conditions.

In high-stress assignments, responders should be routinely rotated. Where manpower is limited, responders should alternate from high-stress positions to lower-stress positions.

Fifteen-to-thirty-minute rest periods should be scheduled every two hours during an emergency situation for all responders; and if possible, provided with:

- Shelter from weather, dry clothes, and a place to sit or lie down away from the scene.
- Warm food, high protein snacks and juices.
- An opportunity to share their feelings with co-workers.

## Fire / Explosion

### Fire Explosion Consideration

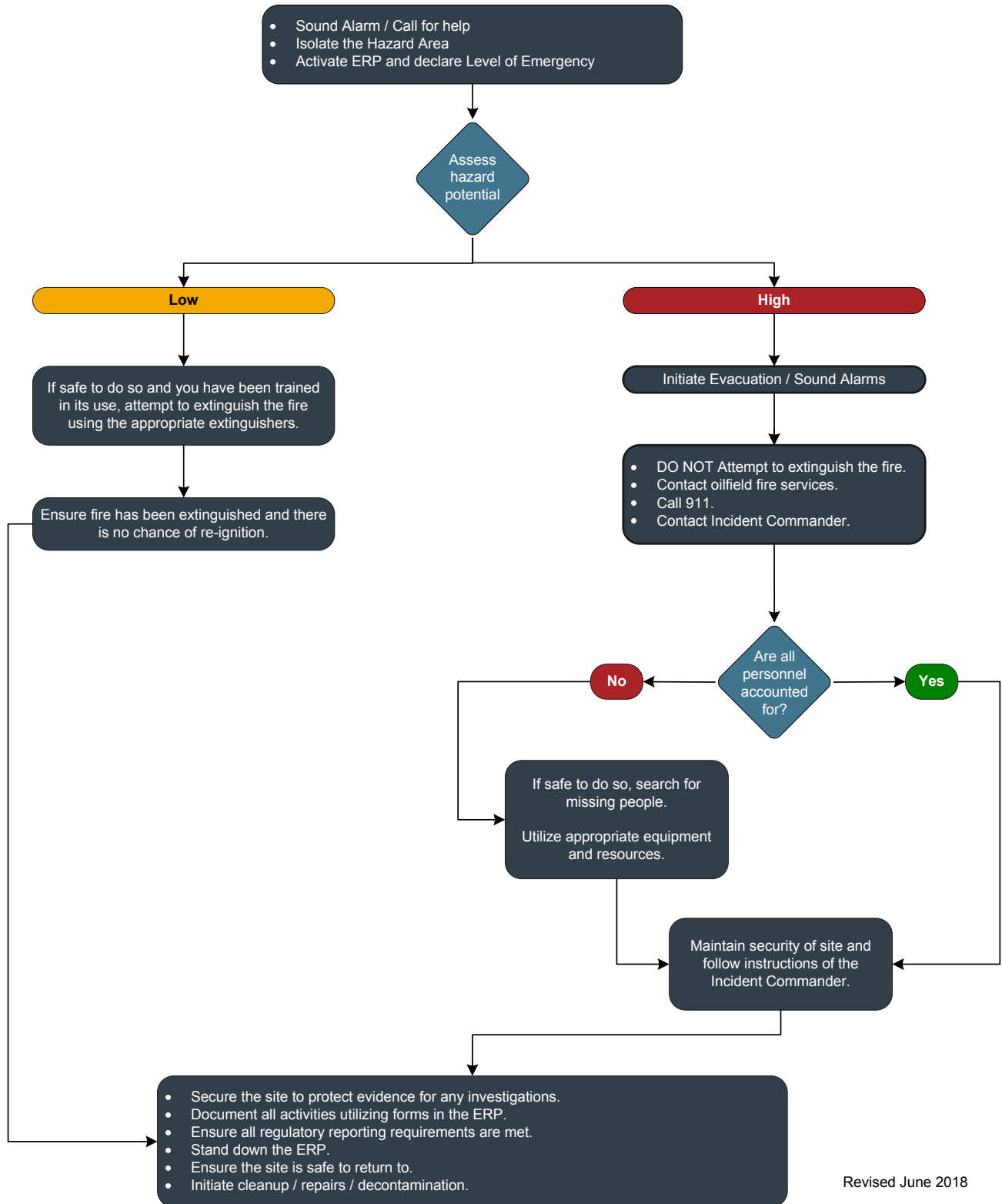

Revised June 2018

## Fire / Explosion, continued

An explosion is a mechanical or chemical reaction that suddenly releases a large amount of energy, resulting in a shock or pressure wave that causes damage, high temperature and usually a release of gases. Explosions can be loosely categorized according to reaction time. High explosives react quickly within a millionth of a second, while low explosives react more slowly. Important general guidelines must be followed for all fires or explosions to ensure the safety of the public, employees and environment. When encountering different types of fire, the appropriate firefighting services should always be contacted. This is especially important for fuel-related, structure-related or forest-related fires to decrease the risk of major damage. For oil-related fires, industrial fire-fighters are the best equipped to reduce further danger in the area.

If a fire or explosion occurs, the following actions shall be taken:

### Control / Containment:

- If possible;
  - Isolate the source and take reasonable action to extinguish or contain the fire.
  - Shut down all known fuel sources.
  - Shut off high voltage power supplies to equipment in fire-affected area.
  - Shut off fuel to heaters near to, or downwind of fire.
  - Dissipate static electrical charges on bodies of all personnel in area. Grounding may be accomplished by holding onto a metal structure for ten seconds with bare hands.
- Call out to industrial firefighting services.
- Notify the Incident Commander.
- Isolate hazard area or equipment as required.

### External Notifications:

- Follow notification procedures for fires outlined in the Government Notification Matrix in **Section 5: External Agencies**.

## Fire / Explosion, continued

### Classification of Fires

Most fires that occur will fall into one or more of the following categories:

Class / Symbol	Material	Extinguishing Agent
	<p>Ordinary combustible materials, such as wood, paper, cloth, trash, and plastics.</p>	<p>Cooling, blanketing or wetting extinguishing agent is needed. Water and foam extinguishers work on this class of fire.</p>
	<p>Flammable liquids such as gasoline, thinners, oil-based paints and greases; Also includes flammable gases such as propane and butane.</p>	<p>Extinguishers for this type of fire include carbon dioxide, dry chemical and halogenated or clean agent types.</p>
	<p>Energized electrical equipment, such as motors transformers and appliances.</p>	<p>The most common type of extinguisher for this class is a carbon dioxide extinguisher. A dry chemical or clean agent extinguisher can also be used.</p>
	<p>Combustible metals such as magnesium, sodium, potassium, titanium and aluminum.</p>	<p>Special dry powder extinguishing agents are required for this class of fire, and must be tailored to the specific hazardous metal.</p>
	<p>Cooking oils and greases such as animal fats and vegetable fats.</p>	<p>A wet chemical fire extinguisher agent is used for this class of fire.</p>

Source: [www.femalifesafety.org](http://www.femalifesafety.org)

## Fire / Explosion, continued

### Response Actions Based on Type of Fire

#### Process Fire

**Definition:**

Process fires include those within or adjacent to: fractionation skids, compressors, exchangers, vessels (also see BLEVE / LPG), piping, tanks/bullets (also see BLEVE / LPG).

**Hazards:**

Process fires can be a particular hazard where flammable materials are present.

**Response Actions:**

Deny or restrict access to the area, shut down and depressurize any related or additional process equipment, if safe to do so. Do not attempt to extinguish a process fire if you are not properly trained.

#### Sulphur Fire

**Definition:**

Sulphur dust suspended in air ignites easily, and can cause an explosion in confined areas.

**Hazards:**

Toxic gases will form upon combustion. Bulk/solid forms burn only at a moderate rate, whereas dust burns with explosive violence. Burning sulphur decomposes into toxic sulphur oxide gases such as sulphur dioxide (SO<sub>2</sub>) and hydrogen sulphide (H<sub>2</sub>S) which is toxic if inhaled.

**Response Actions:**

The following precautions should be taken when dealing with sulphur fires:

- Prevent human contact or inhalation. Fire may produce irritating and/or toxic gases.
- Wear full faced, self-contained breathing apparatus and full protective clothing.
- Use a water fog, NOT water, to extinguish fire.
- Cool fire, surrounding area, and containers, tanks, and trucks to below 154°C in order to diminish the fire.
- Evacuate the area, except for essential personnel.
- Isolate the area with a 1600m radius.

Trained personnel, local fire departments or contract fire services should only attempt to control a sulphur fire. To ensure public protection, evacuate 1600 meters in all directions and ensure air monitoring is set up downwind of fire and the smoke plume. Continually assess evacuation zone based on air quality readings.

## Fire / Explosion, continued

### Electrical System Fire

**Definition:**

Electrical fires are fires involving potentially energized electrical equipment. This sort of fire may be caused by, for example, short-circuiting machinery or overloaded electrical cables.

**Hazard:**

Electrical fires can quickly get out of control and can cause serious damage and threaten lives.

**Response Actions:**

Electrical fire may be fought in the same way as an ordinary combustible fire, but water, foam, and other conductive agents are not to be used. While the fire is, or could possibly be electrically energized, it can be fought with any extinguishing agent rated for electrical fire. Carbon dioxide CO<sub>2</sub>, FM-200 and dry chemical powder extinguishers such as PKP and even baking soda are especially suited to extinguishing this sort of fire. Once electricity is shut off to the equipment involved, it will generally become an ordinary combustible fire. Water conducts electricity; throwing water on an electrical fire can cause the fire to get larger.

### Grass Fire

**Definition:**

A grass fire is a fire that burns large amounts of grass. They mainly occur in grasslands and or Great Plains.

**Hazards:**

Grassfires spread rapidly, travelling at speeds of up to 25 km/hr, and can quickly threaten lives and properties.

**Response Actions:**

Threatening grass fires have a potential to involve the licensee's and other area operators' facilities, pipelines and well sites, therefore guidelines to minimize damage to any property need to be followed. To protect the licensee's and other area user property, it is important to follow these guidelines:

- Notify other area operators of the emergency.
- Isolate and shut in all affected facilities if safe to do so.
- For small grass fires extinguish using a shovel or ABC type fire extinguisher. If it enters coulees, along rivers, or into large areas of trees or forests, contact the local fire department and local forestry office for assistance.
- For larger grass fires do not attempt to extinguish, but contact local fire department and local forestry office.

## Fire / Explosion, continued

### Natural Gas Liquid Fire

**Definition:**

Liquid natural gas is very flammable after vaporization to a gaseous phase.

**Hazard:**

If liquid natural gas is spilled, it vaporizes. The natural gas vapours are initially heavier than air and they form a cloud close to the ground, which is pushed downwind and eventually dissipates. If a viable ignition source is present where a vapour cloud exists at a 5%–15% concentration in air, the vapour cloud can ignite and burn. A vapour cloud, formed by an LNG spill, could drift downwind into populated areas. An LNG fire gives off a tremendous amount of heat. Water will react violently with the LNG and may cause the fire to flare up and intensify.

**Response Actions:**

A solid stream of water should never be used to extinguish this type because it can cause the fuel to scatter, spreading the flames. The most effective way to extinguish a liquid or gas fueled fire is by inhibiting the chemical chain reaction of the fire, which is done by dry chemical and Halon extinguishing agents, although smothering with CO<sub>2</sub> or, for liquids, foam is also effective.

### BLEVE

**Definition:**

BLEVE is an acronym for Boiling Liquid Expanding Vapour Explosion. It is the term for an uncontrolled fire and explosion of vapour as it escapes from a ruptured vessel of pressurized / liquefied gas. Such explosions can be extremely hazardous.

**Hazards:**

The hazards associated with a BLEVE include the initial impact of the blast, the fireball and radiation from the explosion and projectiles (pieces of the tank and nearby equipment) that are rocketed from the explosion.

**Response Actions:**

- Contact Emergency Response Assistance Canada (ERAC) for assistance with emptying any damaged tanks.
  - Under the plan, response is provided for the following chemicals: LPG - UN 1075, Propane - UN 1978, Butane - UN 1011, Propylene - UN 1077, Butylene - UN 1012, Isobutane - UN 1969, Isobutylene - UN 1055, Butadiene-1,3 - UN 1010
- If safe to do so, attempt to extinguish any fires before they come in contact with any storage bullets.
- Call 911 to obtain assistance with fire suppression. Ensure all responders are made aware of the hazards.
- Flowing water can be used to cool the tanks in order to prevent or delay a BLEVE; however, this requires a significant amount of water and should not be attempted unless an unlimited water supply can be located and the tank can be approached safely.
- Evacuate all personnel and isolate the area to a 1600m radius.
- Evaluate the tank from a safe distance away. Choose an upwind position to the side of the tank if possible.
- Leave the area immediately if you hear a rising sound from venting safety devices or see discoloration of the tank.

## Fire / Explosion, continued

### BLEVE Considerations Based on Tank Capacity

#### BLEVE

Capacity		Diameter		Length		Propane Mass		Minimum time to failure for severe torch	Approximate time to empty for engulfing fire	Fireball Radius		Emergency Response Distance		Minimum Evacuation Distance		Preferred Evacuation Distance		Cooling Water Flow Rate	
Litres	Gallons	Metres	Feet	Metres	Feet	kg	lbs	Minutes	Minutes	Metres	Feet	Metres	Feet	Metres	Feet	Metres	Feet	Litres/min	Gal/min
100	38.6	0.3	1	1.5	4.9	40	88	4	8	10	33	90	295	154	505	307	1007	94.6	25
400	154.4	0.61	2	1.5	4.9	160	353	4	12	16	53	90	295	244	801	488	1601	189.3	50
2000	772	0.96	3.2	3	9.8	800	1764	5	18	28	92	111	364	417	1368	834	2736	424	112
4000	1544	1	3.3	4.9	16.1	1600	3527	5	20	35	115	140	459	525	1722	1050	3445	598	158
8000	3088	1.25	4.1	6.5	21.3	3200	7055	6	22	44	144	176	577	661	2169	1323	4341	848	224
22000	8492	2.1	6.9	6.7	22	8800	19400	7	28	62	203	247	810	926	3038	1852	6076	1404	371
42000	16212	2.1	6.9	11.8	38.7	16800	37037	7	32	77	253	306	1004	1149	3770	2200	7218	1938	512
82000	31652	2.75	9	13.7	45	32800	72310	8	40	96	315	383	1257	1435	4708	2200	7218	2710	716
140000	54040	3.3	10.8	17.2	56.4	56000	123457	9	45	114	374	457	1499	1715	5627	2200	7218	3539	935

This page is intentionally left blank

## **FIRE / EXPLOSION, continued**

### **FOREST FIRE / WILDFIRE**

#### **Definition:**

A forest fire is an uncontrolled fire in a wooded area. A forest fire is a natural disaster consisting of a fire which destroys a forested area, and can be a great danger to people who live in forests as well as wildlife. Forest fires are generally started by lightning, but also by human negligence or arson, and can burn thousands of square kilometres.

#### **Hazards:**

Forest fires can quickly get out of control and can cause serious damage in agricultural and forested lands.

#### **Response Actions:**

- Notify other area operators of the emergency.
- Isolate and shut in all affected facilities if safe to do so.
- For small fires extinguish using a shovel or ABC type fire extinguisher. If it enters coulees, along rivers, or into large areas of trees or forests, contact the local fire department and local forestry office for assistance.
- For larger fires do not attempt to extinguish the fire. To report a forest fire/wildfire, call:

British Columbia	1-800-663-5555 (Prov-wide) or *5555 (from cell, Prov-wide)
Alberta	310-FIRE (3473) (Prov-wide)
Saskatchewan	1-800-667-9660 (Prov-wide)
Manitoba	1-800-782-0076 (Prov-wide)
Northwest Territories	1-877-NWT-FIRE (698-3473) (Prov-wide)
Ontario	Local Fire Department or 911
Quebec	1-800-463-FEUX (3389) (Prov-wide)

# FIRE / EXPLOSION, continued

## FOREST FIRE / WILDFIRE

### Fire Season Procedure

- Determine a single point of contact to manage wildfire response for either a specific area or discipline (e.g. drilling specific to the Duvernay or drilling as a whole).
- Identify number of staff working in each area
- Ensure all staff have access to transportation if evacuation is required
- Identify the lowest number of staff required to continue operations
- Determine who is considered non-essential staff.
- What is the timeframe to shut in operations?
  - Drilling \_\_\_\_\_
  - Completions \_\_\_\_\_
  - Production Operations \_\_\_\_\_
  - Construction \_\_\_\_\_
- Is there anything that can be done during wildfire season to reduce shut-in timeframe
  - Wireline Plugs?
- Visual Air Quality Assessment conducted regularly
  -

To estimate particulate matter concentrations that are potentially harmful using a visibility assessment use the following procedure:

- 1) Face away from the sun.
- 2) Look for landmarks at known distances.
- 3) Determine the visibility range – the limit of which is the point where even high-contrast objects, like a mountain or a dark building, totally disappear.
- 4) Estimate visibility in kilometres.
- 5) Use the table below to identify the suggested health message and appropriate action, based on the air-quality category.

Table 1: Estimating air quality using visibility

*Adapted from Wildfire Smoke: a guide for public health officials: [www.arb.ca.gov/smp/progdev/pubeduc/wfgv8.pdf](http://www.arb.ca.gov/smp/progdev/pubeduc/wfgv8.pdf)*

Visibility in km	Air Quality Category	Equivalent approx. PM2.5 1-3 hour average in µg/m <sup>3</sup> *
15 km and up	Good	0-40
5-14 km	Moderate/Unhealthy for Sensitive Groups	41-175
2.5-4 km	Unhealthy	176-300
1.5-2 km	Very Unhealthy	301-500
Less than 1 km	Hazardous	over 500

*\*The concentration of an air pollutant (e.g. Particulates less than 2.5 microns in diameter — PM2.5) is given in micrograms (one-millionth of a gram) per cubic meter air or µg/m<sup>3</sup>.*

The visibility index may be unreliable at times when specific landmarks at known distances are unavailable or when visibility is poor e.g., at dawn or dusk and at night. The above index also only applies to the particulate matter (PM) levels in dry air conditions. This method of estimation is not accurate during high humidity conditions.

## FIRE / EXPLOSION, continued

### FOREST FIRE / WILDFIRE

- Active monitoring of wildfire begins when a fire within 50km to operational activity occurs
  - GIS will produce a web map updated daily with our operations and wildfire locations during wildfire season (Mar 1st- Nov 30th)
    - It would be advantageous to plot more transient activities on this map as well (e.g. Drilling/Completions activity)
  - Emergency Response Coordinator and operational points of contact will regularly monitor this map. Once the 50km threshold is reached the coordinator will contact the operational point of contact.
  - If the fire is deemed a threat to operations an area specific map will be produced with markers identifying distance to fire as well as a map of all heavy equipment and water sources wildfire responders could utilize.
- Once a fire is deemed a threat a determination as to what kind of evacuation will take place is required
  - Tactical evacuation: May occur when the emergency wildfire situation has escalated with little notice where authorities recommend an immediate evacuation due to an emerging wildfire threat.
  - Strategic evacuation: May occur when a wildfire threat is not imminent however is likely to impact the operation. Projected time of impact of a probable threat will be provided by provincial or municipal authorities. This may also occur when smoke from wildfire is affecting air quality of the operation where a full or limited evacuation is recommended.
- The identification of evacuation routes within the area must be made at this time as it will be a factor in determining evacuation type and evacuation trigger points.
- Evacuation trigger points must be identified.
  - trigger points help decide when to change or modify operations. A trigger point is defined as a point of reference from which predetermined actions take place. It is important to consider factors specific to the operational environment when developing trigger points for wildfire response planning. These may include time to evacuate, distance of the operation from the fire or smoke, or physical features such as a river or road.

Wildfire evacuations could involve a few different scenarios and it is important to understand how your trigger points will relate to various threats.

External resources and expertise can be utilized where internal expertise is limited. Operational personnel should be involved in developing these triggers, and emergency response plans and associated trigger points should be communicated to workers.

- If it is determined that a strategic evacuation is preferred evacuation timeframes must be determined. A generally used fire speed rate is between 8-10 km/hr. This is only an estimate though and cannot take into account extreme weather conditions like drought or high winds.

## FIRE / EXPLOSION, continued

### FOREST FIRE / WILDFIRE

- Evacuation trigger point determination needs to be made for non-essential staff
  - When wildfire reaches a distance of \_\_\_\_\_ evacuate all nonessential Production Operations/Camp Staff.
  - When wildfire reaches a distance of \_\_\_\_\_ evacuate all nonessential Drilling Staff.
  - When wildfire reaches a distance of \_\_\_\_\_ evacuate all nonessential Completions Staff.
  - When wildfire reaches a distance of \_\_\_\_\_ evacuate all nonessential Construction Staff.
- Evacuation trigger point determination needs to be made for all essential staff
  - When wildfire reaches a distance of \_\_\_\_\_ initiate shutdown procedures evacuate all remaining Production Operations/Camp Staff.
  - When wildfire reaches a distance of \_\_\_\_\_ initiate shutdown procedures evacuate all remaining Drilling Staff.
  - When wildfire reaches a distance of \_\_\_\_\_ initiate shutdown procedures evacuate all remaining Completions Staff.
  - When wildfire reaches a distance of \_\_\_\_\_ initiate shutdown procedures evacuate all remaining Construction Staff.

# Transportation Incidents

## First On-Scene Transportation (Road, Rail, Marine) Incident Flowchart

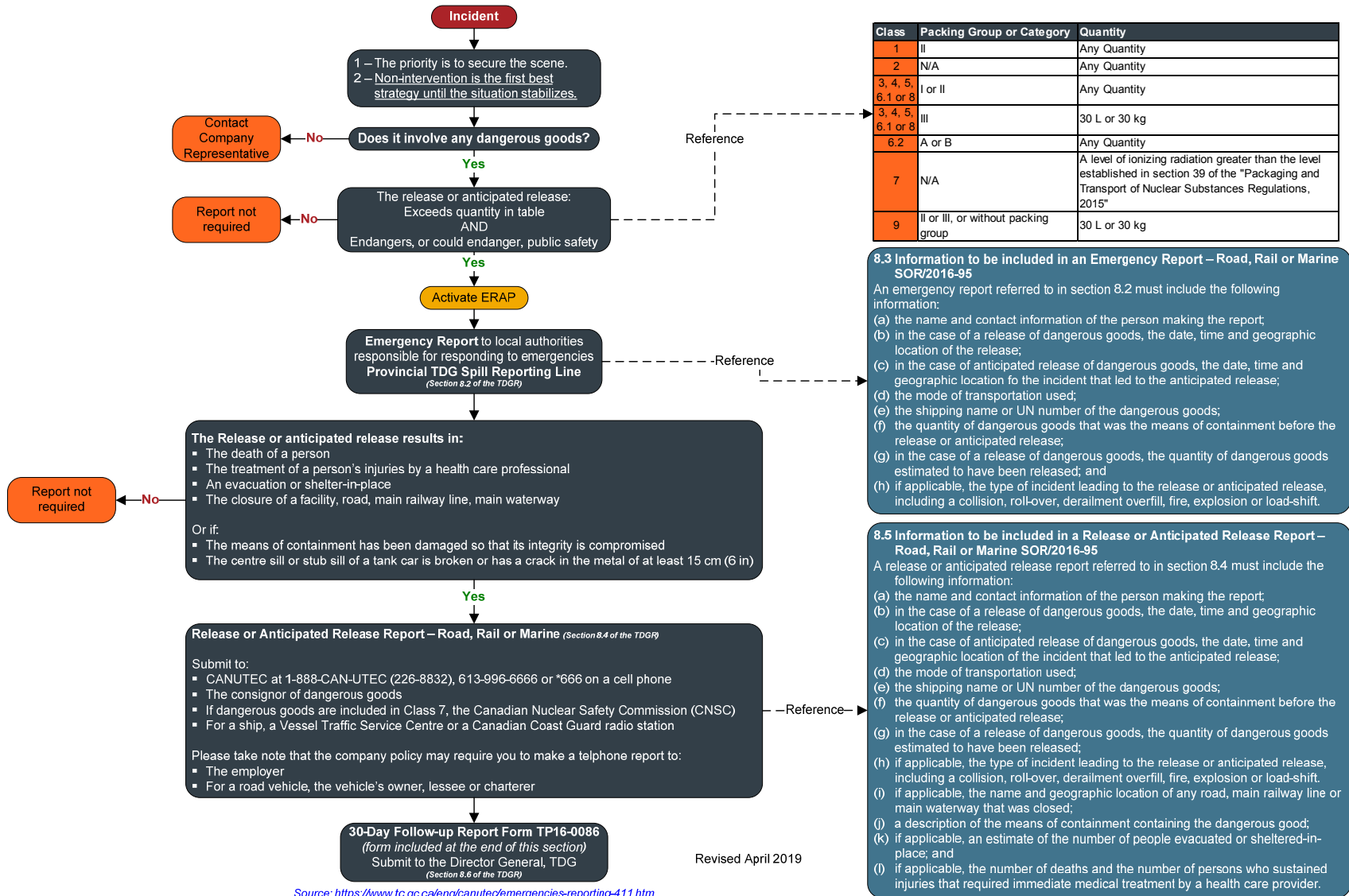

# Transportation Incidents, continued

## Loss, Theft or Unlawful Interference Reporting Flowchart

### Loss or Theft Report Protocol

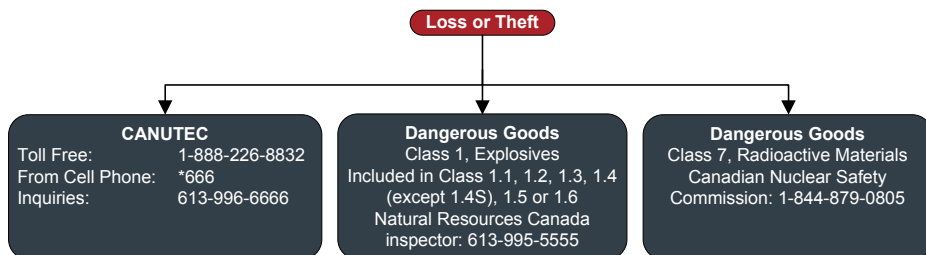

- 1. Any Quantity of Dangerous Goods in the following Primary and Subsidiary Classes:**
- Explosives included in Class 1.1, 1.2, or 1.3
  - Toxic gases included in Class 2.3
  - Organic peroxides included in Class 5.2, Type B, liquid or solid, temperature controlled
  - Toxic substances included in Class 6.1 and Packing Group I
  - Infectious substances included in Class 6.2
  - Radioactive materials included in Class 7

- 2. A Total Quantity of 450kg or more, in the case of Dangerous Goods in the following Primary and Subsidiary Classes:**
- Explosives included in Class 1.4 (except for 1.4S), 1.5 or 1.6
  - Flammable gases included in Class 2.1
  - Flammable gases included in Class 3
  - Desensitized explosives included in Class 3 or 4.1
  - Substances liable to spontaneous combustion, pyrophoric solids or liquids, included in Class 4.2 and Packing Group I or II
  - Water-reactive substances included in Class 4.3 and Packing Group I or II
  - Oxidizing substances included in Class 5.1 and Packing Group I or II
  - Corrosives included in Class 8 and Packing Group I or II

- 3. Any Quantity of one of these Dangerous Goods:**
- UN1261, Nitromethane,
  - UN1357, Urea Nitrate, Wetted with not less than 20%,
  - UN1485, Potassium Chlorate,
  - UN1486, Potassium Nitrate,
  - UN1487, Potassium Nitrate and Sodium Nitrate Mixture,
  - UN1489, Potassium Perchlorate,
  - UN1495, Sodium Chlorate,
  - UN1498, Sodium Nitrate,
  - UN1499, Sodium Nitrate and Potassium Nitrate Mixture,
  - UN1511, Urea Hydrogen Peroxide,
  - UN1796, Nitrating Acid Mixture with more than 50% nitric acid,
  - UN1826, Nitrating Acid Mixture, Spent, with not more than 50% nitric acid,
  - UN1942, Nitrating Acid Mixture, with not more than 0.2% combustible substances, including any organic substance calculated as carbon, to the exclusion of any other added substance,
  - UN2014, Hydrogen Peroxide, Aqueous Solution with not less than 20% but not more than 60% hydrogen peroxide (stabilized as necessary),
  - UN2015, Hydrogen Peroxide, Aqueous Solution, Stabilized with more than 60% hydrogen peroxide; or Hydrogen Peroxide, Stabilized,
  - UN2031, Nitric Acid, other than red fuming
  - UN2032, Nitric Acid, Red Fuming
  - UN3149, Hydrogen Peroxide and Peroxyacetic Acid Mixture with acid(s), water and not more than 5% peroxyacetic acid, Stabilized
  - UN3370, Urea Nitrate, Wetted, with not less than 10% water by mass.

Reference

### Unlawful Interference Report Protocol

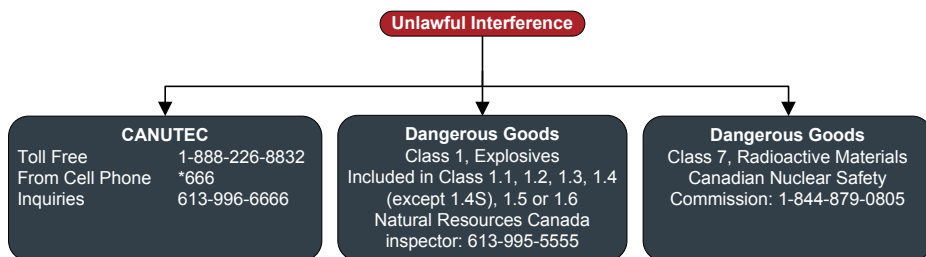

Revised June 2018

## Transportation Incidents, continued

### Motor Vehicle Accidents

The first person on scene will follow the First Person On-Scene Transportation Incident Flowchart, then:

- Record and report the following:
  - Driver's name, address and phone number.
  - Driver's license number.
  - Vehicle license plate number, make, model, year and colour.
  - Name of injured and nature of injury.
  - Witnesses' name, address and phone numbers.
  - Time and location of accident.
  - Actions taken.
  - Weather conditions.
  - Individuals and organizations notified.
- Make a statement to the RCMP / police.
- Chronologically document all actions, decisions, contacts and requests on an ICS 214 Activity Log (see **Section 6: Forms**).

The Incident Commander will be engaged through the initial notification and is responsible to:

- Ensure required communication occurs with internal and external personnel.
- Ensure no unauthorized personnel enter the emergency area.
- Ensure evidence is secured for investigation.
- Conduct an initial debriefing to all emergency personnel and delegate areas of responsibility.
- Chronologically document all actions, decisions, contacts and requests on an ICS 214 Activity Log (refer to **Section 6: Forms**).

In case of a hazardous material spill:

- Ensure your own personal safety.
- Refer to **Section 4: Spill Response**.

In case of a vehicle fire:

- Ensure your own personal safety.
- Call for assistance.
- Use an ABC fire extinguisher for cab, electrical, cargo space or trunk and engine fires.

*Note: RCMP/Police must be notified when an injury or fatality has occurred and / or vehicle damages exceed \$1000.00.*

## Transportation Incidents, continued

Refer to the Transport Canada - 2020 Emergency Response Guidebook for further details regarding the Initial Phase of a Dangerous Goods / Hazardous Materials Transportation Incident.

### Emergency Response Assistance Canada (ERAC) Plan

Internal notification is required in the event of a LPG incident. The extent of the notification depends on the severity of the incident. If the Emergency Response Assistance Canada (ERAC) Plan has been implemented, the incident is considered serious. Examples of serious incidents include: fire, spill, rupture, collision involving tanker car, tanker car overturning, etc.

Notification of an LPG incident outside of a plant site will most likely come from Emergency Response Assistance Canada (ERAC) in Calgary, Alberta.

If the call is NOT from ERAC, contact ERAC immediately and confirm the plan has been initiated.

If you receive the initial call, contact the ERAC:

- Refer to **Section 5: External Agencies** or **Area Specific Information** for contact information

Refer to the First On-Scene Incident Flowchart on the previous page for information on when to contact.

### CANUTEC – Canadian Transport Emergency Centre

CANUTEC is operated by Transport Canada to assist emergency response personnel in handling dangerous goods emergencies involving all modes of transportation.

In an emergency, CANUTEC may be called collect at:

- Refer to **Section 5: External Agencies** or **Area Specific Information** for contact information

CANUTEC **MUST** be notified in the case of the following:

- Lost, stolen or misplaced infectious substances.
- An incident involving infectious substances.
- An accidental release from a cylinder that has suffered a catastrophic failure.
- An incident where the shipping documents display CANUTEC's telephone number as the emergency number.
- A dangerous goods incident in which a railway vehicle, a ship, an aircraft, an aerodrome or an air cargo facility is involved.

## Transportation Incidents, continued

### Dangerous Goods References

#### Agency Contacts

Although technical information and emergency response assistance can be obtained from CANUTEC, there are federal and provincial regulations requiring the reporting of dangerous goods incidents to certain authorities.

- Refer to **Section 5: External Agencies** or **Area Specific Information** for contact information

*Note: The nearest police department must be notified in the case of lost, stolen or misplaced explosives, radioactive materials or infectious substances.*

The appropriate federal agencies must be notified if affected:

- Refer to **Section 5: External Agencies** or **Area Specific Information** for contact information

#### TDG Reportable Quantities

Refer to Petroleum Release Reporting Requirements chart in **Section 4: Spill Response**.

This page is intentionally left blank

# Transportation Incidents, continued

## Rail Car Identification Chart

### 117 Pressure tank car

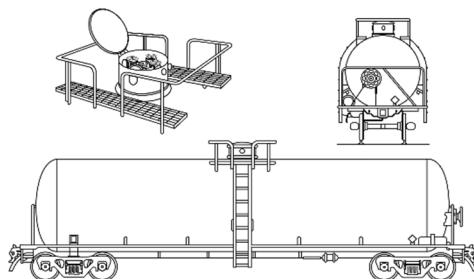

- For flammable, non-flammable, toxic and/or liquefied compressed gases
- Protective housing
- No bottom fittings
- Pressures usually above 40 psi

### 131 Non-pressure / low pressure tank car

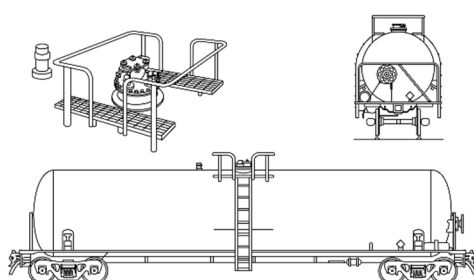

- Known as **general service tank car**
- For variety of hazardous and non-hazardous materials
- Fittings and valves normally visible at the top of the tank
- Some may have bottom outlet valve
- Pressures usually below 25 psi

### 128 Non-pressure / low pressure tank car (TC117, DOT117)

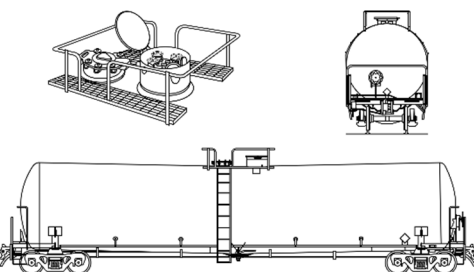

- For flammable liquids (e.g., Petroleum crude oil, ethanol)
- Protective housing separate from manway
- Bottom outlet valve
- Pressures usually below 25 psi

### 111 Box car

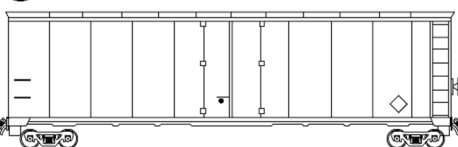

- For general freight that carry bulk or non-bulk packages
- May transport hazardous materials/dangerous goods in small packages or "tote bins"
- Single or double sliding door

### 140 Hopper car

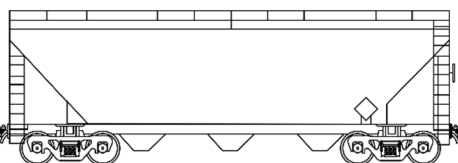

- For bulk commodities and bulk cargo (e.g., coal, ore, cement and solid granular materials)
- Bulk lading discharged by gravity through the hopper bottom doors when doors opened

## Transportation Incidents, continued

### Rail Car Identification Chart, continued

**COMMON MARKINGS ON RAIL CARS:** reporting marks and car number, load limit (pounds or kilograms), empty weight of car, placard, tank qualification and pressure relief device information, car specification, and commodity name.

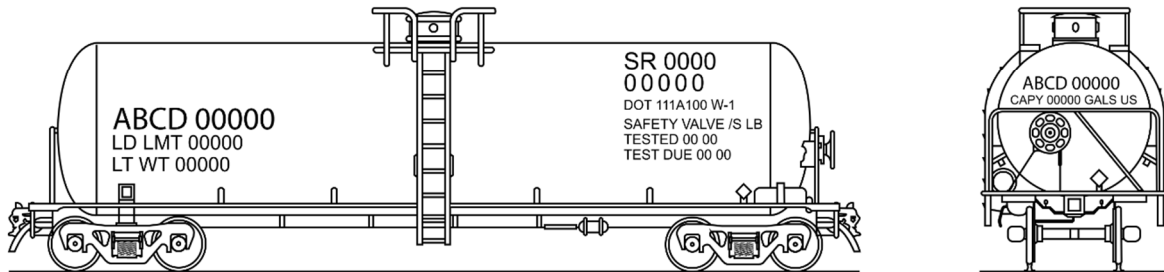

**CAUTION:** Emergency response personnel must be aware that rail tank cars vary widely in construction, fittings and purpose. Tank cars could transport products that may be solids, liquids or gases. The products may be under pressure. It is essential that products be identified by consulting shipping documents or train consist or contacting dispatch centres before emergency response is initiated.

The information stencilled on the sides or ends of tank cars, as illustrated above, may be used to identify the product utilizing:

- the commodity name shown; or
- the other information shown, especially reporting marks and car number which when supplied to a dispatch centre, will facilitate the identification of the product.

**The recommended guides should be considered as last resort if the material cannot be identified by any other means.**

*Source: 2020 Emergency Response Guidebook*

## Transportation Incidents, continued

### Road Trailer Identification Chart

**WARNING:** Road trailers may be jacketed, the cross-section may look different than shown and external ring stiffeners would be invisible.

**NOTE:** An emergency shut-off valve is commonly found at the front of the tank, near the driver door.

**117 MC331, TC331, SCT331**

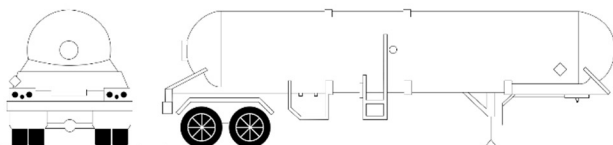

- For liquefied compressed gases (e.g., LPG, ammonia)
- Rounded heads
- Design pressure between 100-500 psi

**117 MC338, TC338, SCT338, TC341, CGA341**

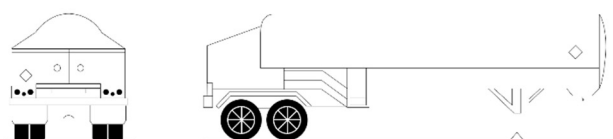

- For refrigerated liquefied gases (cryogenic liquids)
- Similar to a "giant thermo-bottle"
- Fitting compartments located in a cabinet at the rear of the tank
- MAWP between 25-500 psi

**131 DOT406, TC406, SCT306, MC306, TC306**

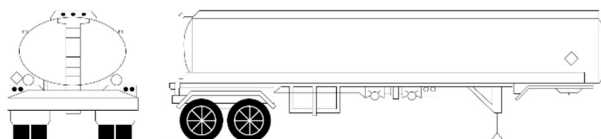

- For flammable liquids (e.g., gasoline, diesel)
- Elliptical cross-section
- Rollover protection at the top
- Bottom outlet valves
- MAWP between 3-15 psi

**137 DOT407, TC407, SCT307, MC307, TC307**

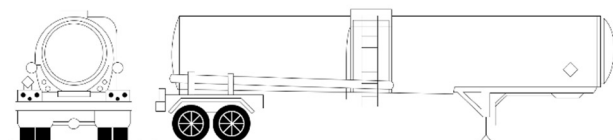

- For toxic, corrosive, and flammable liquids
- Circular cross-section
- May have external ring stiffeners
- MAWP of at least 25 psi

**137 DOT412, TC412, SCT312, MC312, TC312**

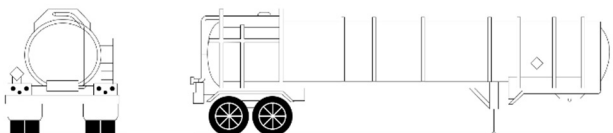

- Usually for corrosive liquids
- Circular cross-section
- External ring stiffeners
- Tank diameter is relatively small
- MAWP of at least 15 psi

## Transportation Incidents, continued

### Road Trailer Identification Chart, continued

112 TC423

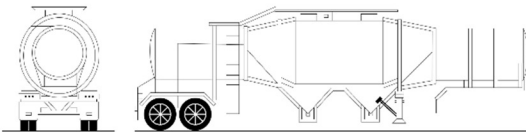

- For emulsion and water-gel explosives
- Hopper-style configuration
- MAWP between 5-15 psi

117 Compressed Gas/Tube Trailer

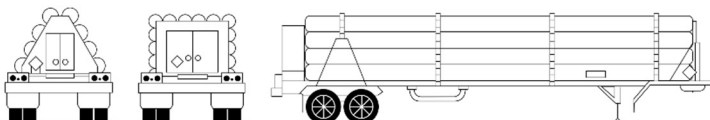

134 Dry Bulk Cargo Trailer

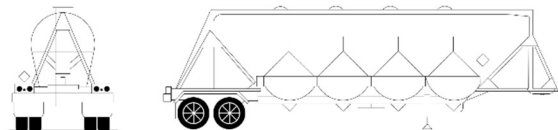

111 Intermodal Freight Container

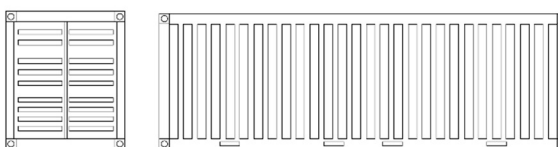

137 Vacuum Tanker



117 Intermodal Tank

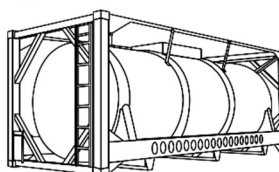

111 Mixed Cargo

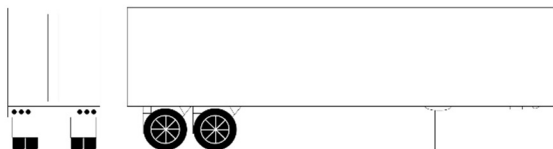

**CAUTION:** This chart depicts only the most general shapes of road trailers. Emergency response personnel must be aware that there are many variations of road trailers, not illustrated above, that are used for shipping chemical products. The suggested guides are for the most hazardous products that may be transported in these trailer types.

**The recommended guides should be considered as last resort if the material cannot be identified by any other means.**

Source: 2020 Emergency Response Guidebook

# Transportation Incidents, continued

## Table of Markings, Labels, and Placards

Use this table only if materials cannot be specifically identified by using the shipping paper, numbered placard, or orange panel number.

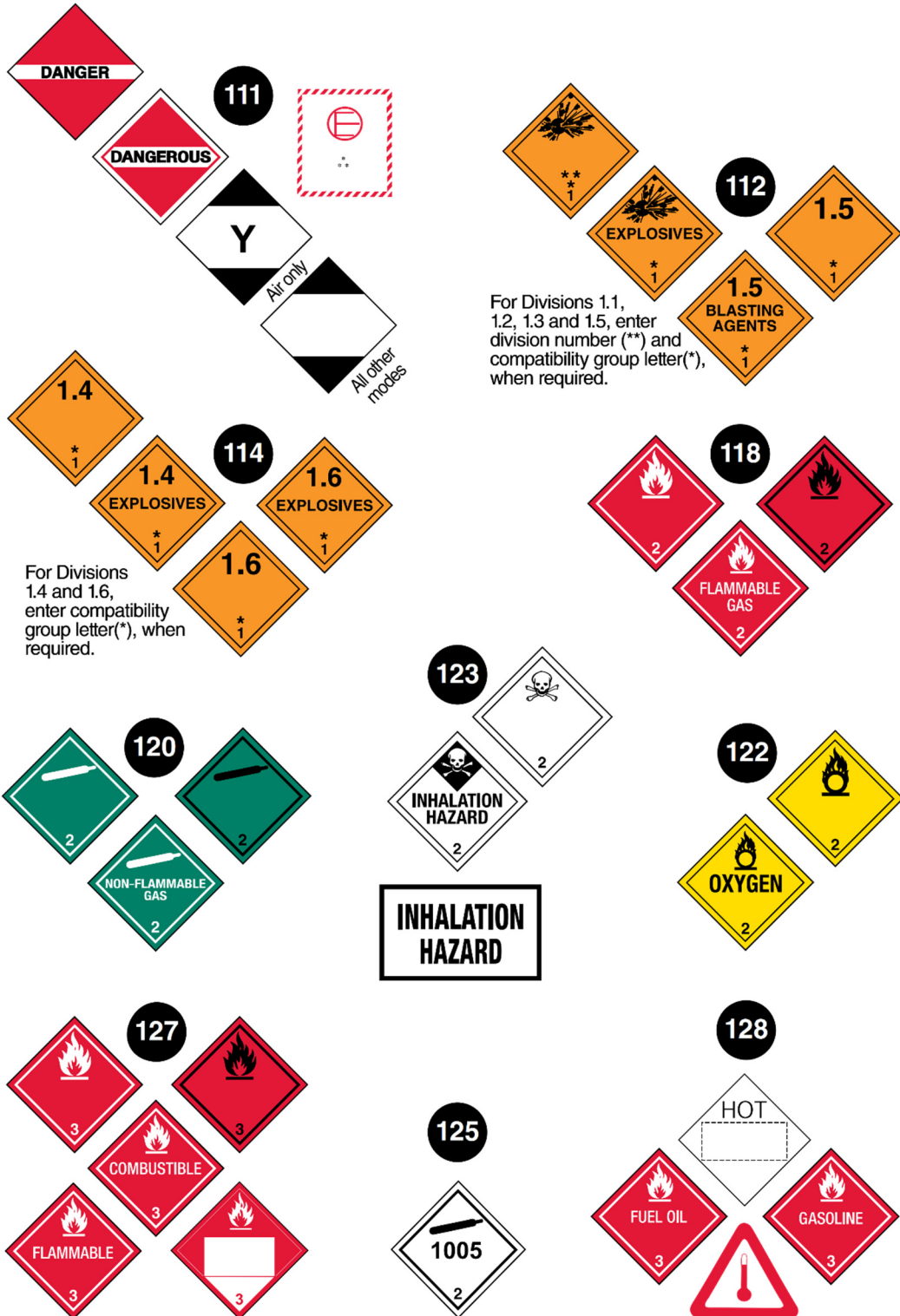

**111** DANGER (Red diamond), DANGEROUS (Red diamond), Y (White diamond with black border), Air only (White diamond with black border), All other modes (White diamond with black border), and a red-bordered square with a white circle and a red slash.

**112** Explosives (Orange diamond with black border), 1.5 (Orange diamond with black border), and 1.5 BLASTING AGENTS (Orange diamond with black border).

**114** 1.4 (Orange diamond with black border), 1.4 EXPLOSIVES (Orange diamond with black border), 1.6 (Orange diamond with black border), and 1.6 EXPLOSIVES (Orange diamond with black border).

**118** 2 (Red diamond with black border), 2 (Red diamond with black border), and FLAMMABLE GAS (Red diamond with black border).

**120** 2 (Green diamond with black border), 2 (Green diamond with black border), and NON-FLAMMABLE GAS (Green diamond with black border).

**122** 2 (Yellow diamond with black border), 2 (Yellow diamond with black border), and OXYGEN (Yellow diamond with black border).

**123** 2 (White diamond with black border), 2 (White diamond with black border), and INHALATION HAZARD (White diamond with black border).

**125** 2 (White diamond with black border) and 1005 (White diamond with black border).

**127** 3 (Red diamond with black border), 3 (Red diamond with black border), COMBUSTIBLE (Red diamond with black border), FLAMMABLE (Red diamond with black border), and 3 (Red diamond with black border).

**128** HOT (White diamond with black border), FUEL OIL (Red diamond with black border), GASOLINE (Red diamond with black border), and a red-bordered triangle with a white thermometer.

For Divisions 1.1, 1.2, 1.3 and 1.5, enter division number (\*\*) and compatibility group letter (\*), when required.

For Divisions 1.4 and 1.6, enter compatibility group letter (\*), when required.

# Transportation Incidents, continued

## Table of Markings, Labels, and Placards, continued

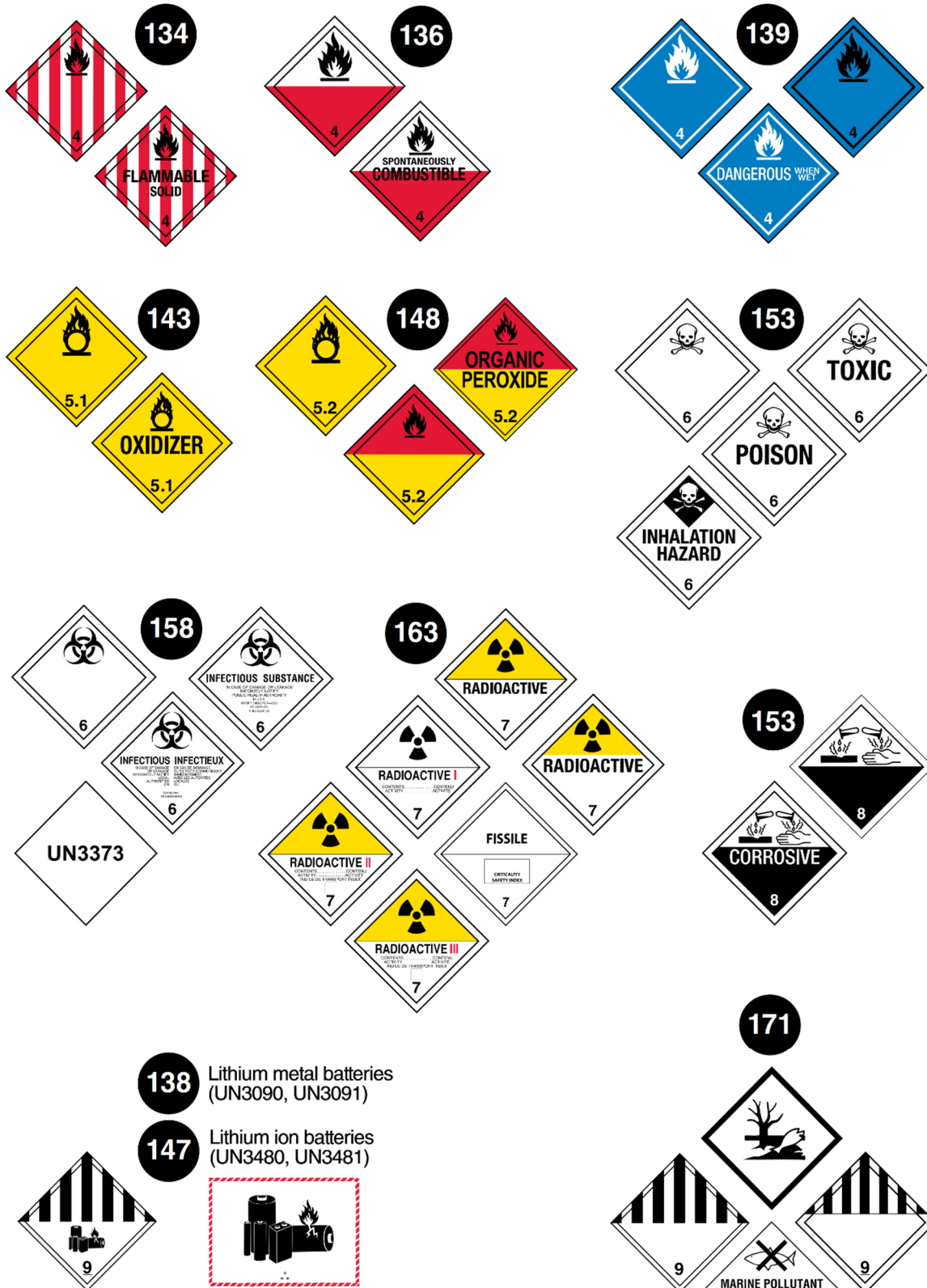



## TRANSPORTATION OF DANGEROUS GOODS 30-DAY FOLLOW-UP REPORT

<b>PART I: REPORTING TIMELINE</b>			
1. Please provide applicable dates and check one box  Date of initial report to CANUTEC (yyyy-mm-dd): _____  30-Day Follow-up Report submission date (yyyy-mm-dd): _____  <input type="radio"/> 30-Day Follow-up Report <input type="radio"/> Update or amendment to 30-Day Follow-up Report • Date original 30-Day Follow-up Report submitted (yyyy-mm-dd): _____			<b>FOR INTERNAL USE ONLY</b>  <b>Road, Rail or Marine Reports</b> <input type="radio"/> Release <input type="radio"/> Anticipated Release  <b>Air Report</b> <input type="radio"/> Dangerous Goods Accident or Incident
<b>PART II: CONTACT INFORMATION</b>			
2. Information of the person completing this report  <input type="checkbox"/> Consignor <input type="checkbox"/> Consignee <input type="checkbox"/> Carrier/Aircraft Operator <input type="checkbox"/> Other			
First Name	Last Name	Title	
Telephone (999-999-9999)	Company Name		
Address		City	Province/Territory
Country	Postal Code (Z9Z 9Z9)	Email	
3. Information on the Consignor, Consignee and Carrier/Aircraft Operator			
<b>Consignor</b>			
First Name	Last Name	Title	
Telephone (999-999-9999)	Company Name		
Address		City	Province/Territory
Country	Postal Code (Z9Z 9Z9)	Email	
<b>Consignee</b>			
First Name	Last Name	Title	
Telephone (999-999-9999)	Company Name		
Address		City	Province/Territory
Country	Postal Code (Z9Z 9Z9)	Email	
<b>Carrier/Aircraft Operator</b>			
First Name	Last Name	Title	
Telephone (999-999-9999)	Company Name		
Address		City	Province/Territory
Country	Postal Code (Z9Z 9Z9)	Email	

PART III: INCIDENT INFORMATION			
4. Please indicate the date and time of the incident			
Date (yyyy-mm-dd)	Time (24-hour system)		
5. Geographic location of the incident			
Address			
City	Province/Territory	Postal Code (Z9Z 9Z9)	GPS Position
If the incident occurred by rail, please indicate the milepost and subdivision		If the incident happened on First Nations Territory, please indicate the Territory name	
Origin of consignment		Destination of consignment	
<input type="radio"/> Same address as consignor <input type="radio"/> Same address as consignee <input type="radio"/> Other (please provide address):		<input type="radio"/> Same address as consignor <input type="radio"/> Same address as consignee <input type="radio"/> Other (please provide address):	
6. Geographic Area (Check only one box)			
<input type="radio"/> <b>Urban</b> Mixed use – residential, commercial <input type="radio"/> <b>Suburban</b> Primary residential <input type="radio"/> <b>Rural</b> Small towns, villages, agricultural lands <input type="radio"/> <b>Wilderness/Remote</b> Little or no population			
7. Mode of Transport (Check all applicable boxes)			
<input type="checkbox"/> Road <input type="checkbox"/> Rail <input type="checkbox"/> Air <input type="checkbox"/> Marine			
8. If MARINE was checked on question 7, please indicate the position of the vessel and the next location at which the vessel will be at anchor or alongside a fixed facility			
Position		Next location	
9. Phase of Transport (Check only one box)			
<input type="radio"/> <b>In-Transit</b> Consignment moving between origin and destination <input type="radio"/> <b>Loading</b> Consignment is being packed or loaded into a means of transport at origin <input type="radio"/> <b>Unloading</b> Consignment is being unpacked or unloaded from a means of transport at destination <input type="radio"/> <b>Temporary Storage</b> Consignment is in short term storage pending transportation			
10. Type of Incident (Check all applicable boxes)			
<input type="checkbox"/> <b>Collision/Sideswipe</b> Moving vehicles striking an object, animal, or another vehicle <input type="checkbox"/> <b>Derailment</b> Railcar leaving the rail tracks <input type="checkbox"/> <b>Ran off road</b> Vehicle enters a soft shoulder, ditch or similar area <input type="checkbox"/> <b>Overturn</b> Vehicle turning on its side or upside down <input type="checkbox"/> <b>Loadshift</b> Shifting of the consignment within a vehicle <input type="checkbox"/> <b>Dropped</b> Means of containment falling unexpectedly <input type="checkbox"/> <b>Struck</b> Means of containment being struck by another object <input type="checkbox"/> <b>Other (Please specify):</b> _____			
11. Type of Release (Check all applicable boxes)			
<input type="checkbox"/> <b>Spill</b> Quick, immediate discharge, emission or escape <input type="checkbox"/> <b>Leak</b> Slow, sporadic or continuous discharge, emission or escape <input type="checkbox"/> <b>Explosion</b> Violent sudden release of energy from means of containment producing a shock wave that may result in fragment projection and/or fire ball <input type="checkbox"/> <b>Fire</b> Burning substances combined with oxygen to typically produce flame, heat and smoke <input type="checkbox"/> <b>BLEVE</b> Boiling Liquid Expanding Vapour Explosion <input type="checkbox"/> <b>Vapour</b> Dispersion in air of particles of a substance that is liquid or solid in its normal state <input type="checkbox"/> <b>Venting</b> Controlled release of gas into the environment <input type="checkbox"/> <b>Anticipated Release</b> Distressed means of containment that is not leaking, venting or otherwise releasing its contents			

12. Information on the Dangerous Goods								
UN Number	Shipping Name	Primary Class	Subsidiary Class(es)	Packing Group or Category	Total Quantity in MOC Before the Release or Anticipated Release	Units (kg, L, etc.)	Estimated Quantity Released (if applicable)	Units (kg, L, etc.)

13. Means of Containment  
Please provide a description of the means of containment involved in the incident by completing the appropriate forms from Annex E of the Guide (TP15294)

**PART IV: CONSEQUENCES**

14. Consequences of the incident (Check all applicable boxes)

**NOTE:** Refer to the Guide for more information on how to complete this section

Human       Property (e.g. product loss, facility, equipment)       Environmental (e.g. contamination of waterway, ground, air)

15. Evacuation of people and buildings/Shelter in place

Was there an Evacuation as a result of the incident?     Yes     No

Was there Shelter in place as a result of the incident?     Yes     No

If **Yes**, please complete the following table

Evacuation of People and Buildings/Shelter in Place	Private Residence Includes houses and other buildings used as dwellings (e.g. Retirement homes)	Public Buildings Includes libraries, hospitals, churches, government buildings, etc.	Workplace Includes warehouse, facility, etc.	Public (Outside) Areas Includes parks, playgrounds, parking lots, etc.
Estimated number of <b>people evacuated</b>				
Estimated number of <b>people sheltered in place</b>				
Estimated number of <b>buildings evacuated</b>				
Size of Evacuation area (square meters)	Duration of Evacuation (hours)		Duration of Shelter in place (hours)	

16. Injuries and/or deaths

Were there any injuries and/or deaths?     Yes (please complete the following table)     No

**Minor Injuries**     Yes     No

**Number of injured requiring immediate first aid treatment at the scene**

Attributed to Dangerous Goods	Attributed to incident	<b>Total</b>

**Moderate Injuries**     Yes     No

**Number of injured requiring immediate emergency treatment in hospital and release shortly after**

Attributed to Dangerous Goods	Attributed to incident	<b>Total</b>

**Major Injuries**     Yes     No

**Number of injured requiring immediate treatment with overnight hospitalization**

Attributed to Dangerous Goods	Attributed to incident	<b>Total</b>

**Deaths**     Yes     No

**Number of deaths**

Attributed to Dangerous Goods	Attributed to incident	<b>Total</b>

17. Please indicate an estimate of costs in Canadian dollars associated with the incident, as applicable

**NOTE:** Refer to the Guide for more information on how to fill this section

Material loss of dangerous goods	Damage incurred by the carrier	Property damage	Emergency response cost	Clean-up cost	<b>Total cost</b>
----------------------------------	--------------------------------	-----------------	-------------------------	---------------	-------------------

18. Infrastructure closure and duration (please use additional sheets for multiple closures)

Was there an infrastructure closure as a result of the incident?  Yes  No

If **Yes**, please complete the following table

Type	Duration of the closure (in hours)
<input type="checkbox"/> <b>Aerodrome</b> – Area of land, water or other supporting surface used either in whole or in part for arrival and departure, movement or servicing of aircraft includes any building, installations and equipment situated thereon or in connection therewith	
<input type="checkbox"/> <b>Air cargo facility</b> – Facility used to receive or transfer cargo carried or to be carried by an aircraft	
<input type="checkbox"/> <b>Facility</b> – Permanent or temporary building or a portion of a building or equipment used in loading or unloading of dangerous goods	
<input type="checkbox"/> <b>Railway</b> – Tracks used by trains	
<input type="checkbox"/> <b>Waterway</b> – Navigable body of water through which a ship or boat can move	
<input type="checkbox"/> <b>Roadway</b> – The strip of land over which motor vehicles circulate, such as dirt road, numbered provincial highway or multiple lane freeway	
<input type="checkbox"/> <b>Runway</b> – the strip of ground on a landing field that aircraft use for landing or takeoff	

19. Geographic location of closure

Address

City	Province/Territory	Postal Code (Z9Z 9Z9)	GPS Position
------	--------------------	-----------------------	--------------

If the incident occurred by rail, please indicate the milepost and subdivision

Name of facility, road, railway or waterway

20. ERAP Requirements

Was an ERAP required under Part 7 of the *Transportation of Dangerous Goods Regulations*?  Yes  No

If **Yes**, please complete the following table

ERAP Reference Number	ERAP Holder
-----------------------	-------------

Address

City	Province/Territory	Postal Code (Z9Z 9Z9)	Telephone of ERAP Holder (999-999-9999)
------	--------------------	-----------------------	---

Email

Level of Response (check all that apply)

No response  First responders on scene  Phone call to ERAP holder  Employee from ERAP holder  Team from ERAP holder

Other: \_\_\_\_\_

**PART V: INCIDENT DESCRIPTION**

21. Please describe:

- The sequence of events that led to the incident
- The means of containment damage or failure, including the size/location of holes, cracks, etc.
- The actions taken at the time it was discovered
- What was done to mitigate the effects of the release
- Contributing factors (e.g. human error, mechanical, equipment, packaging, infrastructure, external, weather, etc.)
- The physical environment (e.g. residential, commercial, industrial, etc.)
- The road's appearance (e.g. flat, straight, inclined, curved, intersection, etc.)
- Timeline of event (e.g. how long it lasted, time of release or discovery, time of first responder arrival, etc.)
- Communications with first responders and with your organization

Photographs and diagrams should be submitted, as required, for clarification. Estimate the duration of the release, if possible. Please use additional sheets if necessary.

**NOTE:** Refer to the Guide for more information on how to complete this section

**PART VI: INCIDENT DESCRIPTION – AIR ONLY**

22. Please describe:

- Any serious jeopardy to persons on any aircraft or aircraft itself
- Any damages to property or environment
- The route by which the dangerous goods were to be or have been transported, including the name of any aerodromes along the route

Aircraft Operator

Air Cargo Facility

**This page is intentionally left blank**

# Weather and Natural Disasters

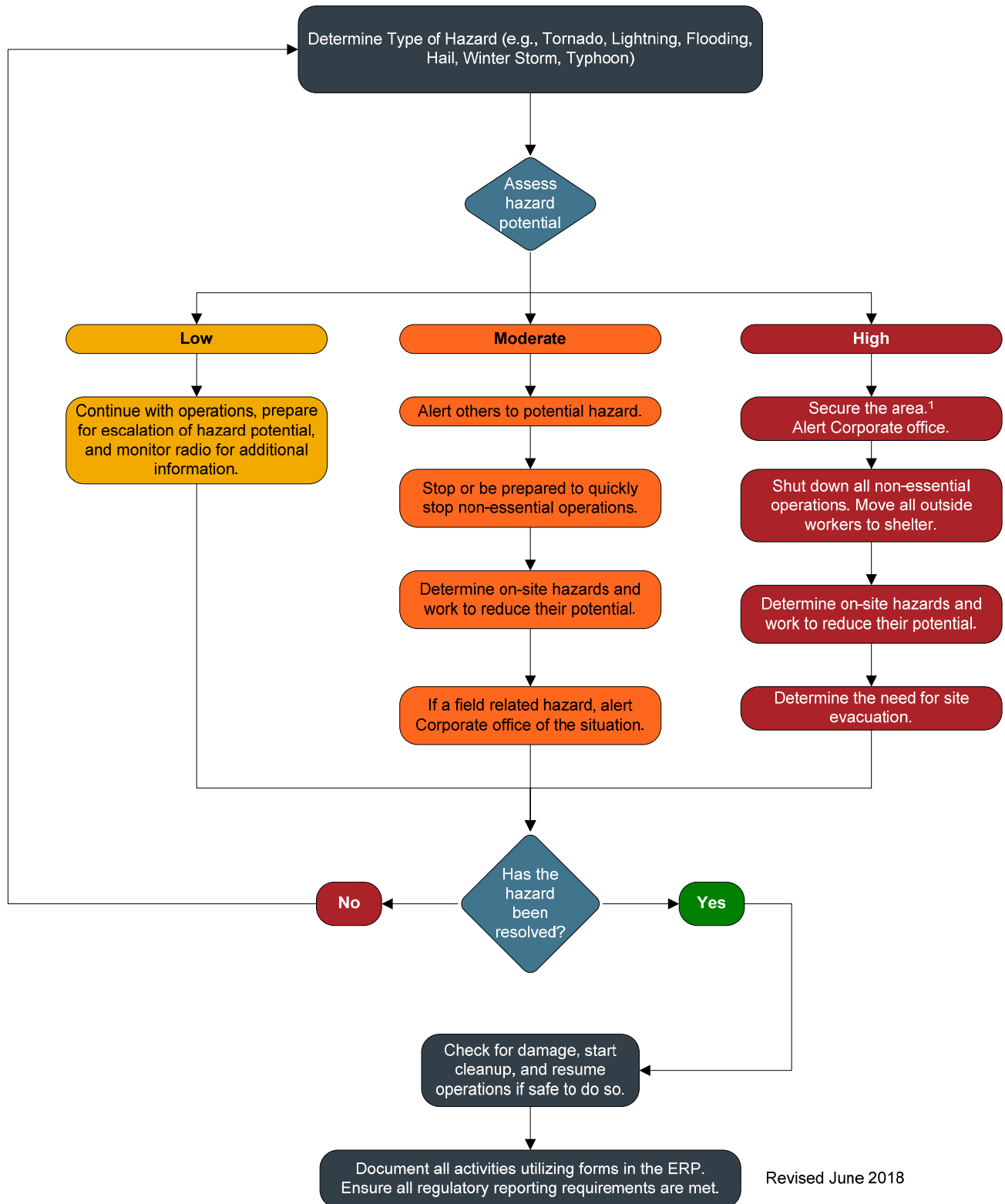

Revised June 2018

<sup>1</sup> The primary concern is for human life. If time allows and it is safe to do so, secure the area (tie down / secure objects that could be moved and cause additional damage).

---

## Weather and Natural Disasters, continued

Severe storms can occur in Canada year round. In the months between May and September, hot and humid weather combined with a cold front could be a sign that a severe storm is brewing. A severe storm can create lightning, hail, severe rain fall (flooding), high winds and tornados. In the months between October and April, severe storms could include blizzards, freezing rain, heavy and blowing snow.

The weather office will issue through the use of radio and television repeated weather watches and warnings. The only exception to these warnings is earthquakes, since they occur by surprise and cannot be predicted.

### Listen for the Warnings

Environment & Climate Change Canada (ECCC) monitors the weather 24-hours a day, seven days a week. If a severe storm is on the horizon, the weather service issues watches, advisories and warnings for that specific storm through national, regional and local radio and television stations, and through ECCC Weatheradio.

#### Weather Watch

This means conditions are favourable for a severe storm, even though nothing has developed yet. It does not mean that the storm will occur. A Weather Watch is usually issued early in the day; keep monitoring weather conditions and listen for updated statements.

#### Weather Warning

This means severe weather is happening or hazardous weather is highly probable. If the warning is for your area, take precautions immediately and listen to your radio for constant updates.

## Earthquake

### General Information

An earthquake (also known as a quake, tremor, or tremblor) is caused by a sudden slip on a fault, which in turn, releases energy in waves that travel through rock to cause the shaking that we feel during an earthquake.

An earthquake cannot be prevented or predicted, but it can be mitigated. The effects of earthquakes include, but are not limited to, shaking and ground rupture. Most common effects or impacts of an earthquake are shaking and ground rupture. Depending on the magnitude of an earthquake, these may cause damage to buildings, pipelines and other rigid structures.

### During an Earthquake

Be aware that some earthquakes are actually foreshocks and a larger earthquake might occur. Minimize movement to a few steps to a nearby safe place and stay indoors until the shaking has stopped and exiting is safe.

---

## Weather and Natural Disasters, continued

### If indoors

- DROP to the ground; take COVER by getting under a sturdy table or other piece of furniture; and HOLD ON until the shaking stops. If there isn't a table or desk near you, cover your face and head with your arms and crouch in an inside corner of the building.
- Stay away from glass, windows, outside doors and walls, and anything that could fall, such as lighting fixtures or furniture.
- Use a doorway for shelter only if it is in close proximity to you and if you know it is a strongly supported, load bearing doorway.
- Stay inside until shaking stops and it is safe to go outside. Research has shown that most injuries occur when people inside buildings attempt to move to a different location inside the building or try to leave.
- Be aware that the electricity may go out or the sprinkler systems or fire alarms may turn on.
- DO NOT use the elevators.

### If outdoors

- Stay outdoors and move away from buildings, streetlights, and utility wires.
- Once in the open, stay there until the shaking stops. The greatest danger exists directly outside buildings, at exits, and alongside exterior walls. Ground movement during an earthquake is seldom the direct cause of death or injury. Most earthquake-related casualties result from collapsing walls, flying glass, and falling objects.

### If in a moving vehicle

- Stop as quickly as safety permits and stay in the vehicle. Avoid stopping near or under buildings, trees, overpasses, and utility wires.
- Proceed cautiously once the earthquake has stopped. Avoid roads, bridges, or ramps that might have been damaged by the earthquake.

### If trapped under debris

- Do not light a match.
- Do not move about or kick up dust. Cover your mouth with a handkerchief or clothing.
- Tap on a pipe or wall so rescuers can locate you. Use a whistle if one is available. Shout only as a last resort. Shouting can cause you to inhale dangerous amounts of dust.

## Weather and Natural Disasters, continued

### Floods

The potential for overland flooding can create a high level of risk for facility damage and environmental impact at petroleum facilities. While there is little that can be done to prevent flooding, actions can be taken to minimize the impact.

It is important to consider that your facility may play a vital role in fuel supply during an emergency situation. It is therefore important that you and the government authority having jurisdiction during a flood emergency have regular and clear communication with regards to facility closure.

#### To shut down a facility which may be flooded:

1. Take a product inventory reading of all underground and aboveground tanks, including water level readings.
2. Seal fill pipe caps to prevent water from entering underground tanks. Close all valves to above ground tanks. **DO NOT PLUG OR SEAL TANK VENT LINES.**
3. Underground tanks should be kept as full of product as possible. Above ground tanks should be filled to a level at least 25% above the estimated/predicted floodwater elevation.
4. Ensure that above ground tanks which could float away are secured or tethered in a manner that would prevent floating from the property.
5. Seal all drains in tank lots.
6. Oil/water separators and product sumps should be skimmed of product using sorbent pads or vacuum trucks as appropriate. Spent sorbent pads should be drummed and every effort must be made to remove any waste from the expected flood zone. If time does not allow for removal the drums must be secured to prevent them from floating away. Close the oil/water separator drain valve.
7. Drums and lubricant cubes should be tied down or otherwise secured to prevent floating.
8. Propane facilities - contact your propane supplier for appropriate flood emergency procedures.
9. Secure used oil collection cabinets. Every effort must be made to remove all waste oil from the expected flood zone. If waste oil from the cabinet drains to a waste oil underground tank, ensure the connection is tight.
10. Secure containers of chemicals, cleaning agents, pesticides, etc. Every effort must be made to remove these products from the expected flood zone. If they cannot be moved to a safe location, store these containers at high elevations in a manner that prevents them from floating off the property or leaking into floodwaters.
11. If the facility is to be closed/evacuated, shut down electrical power to the site at the main breaker. Contact the power service utility company to determine if the power service to the facility is going to be cut-off.
12. Shut down other utilities to the site including natural gas and potable water. If water is obtained from a water well, secure the well using a well seal.
13. Shut down all appliances, including hot water tanks, furnaces, etc.
14. Lock all doors and gates to the facility.
15. Post a sign in a prominent location identifying the names and telephone numbers where key company personnel can be contacted during the emergency.

## Weather and Natural Disasters, continued

### To start-up a facility which has been flooded:

1. Re-activate utilities to the site (natural gas, water, electricity) and appliances using qualified utility service personnel, where required.
2. Take product inventory readings and water dips of all tanks to determine if product has leaked out from the tanks or water has entered the tanks.
3. Take appropriate measures to test product quality.
4. Propane facilities – contact your propane supplier for recommissioning your propane facilities.
5. Pump out water from sumps and containment pans using a qualified petroleum contractor.
6. Follow all re-entry procedures and requirements for health and safety as provided by your local government authority (disinfection, potable water testing, etc.).

Government agencies monitor weather patterns, precipitation and provincial water levels and flows. They provide a comprehensive series of public advisories about potential flooding. These include river stage-up advisories, ice-jam warnings, high stream flow advisories, flood watches and flood warnings; for more information visit the following websites:

Alberta	Alberta Environment <a href="http://environment.alberta.ca/forecasting/advisories/">http://environment.alberta.ca/forecasting/advisories/</a>
British Columbia	Ministry of Forests, Lands and Natural Resource Operations – River Forecast Centre <a href="http://bcrcfc.env.gov.bc.ca/warnings/index.htm">http://bcrcfc.env.gov.bc.ca/warnings/index.htm</a>
Manitoba	Government of Manitoba – Flood Information <a href="http://www.gov.mb.ca/flooding/index.html">http://www.gov.mb.ca/flooding/index.html</a>
Saskatchewan	Saskatchewan Watershed Authority <a href="https://www.wsask.ca/Lakes-and-Rivers/Stream-Flows-and-Lake-Levels/">https://www.wsask.ca/Lakes-and-Rivers/Stream-Flows-and-Lake-Levels/</a>

### What to do during a flood

- Gather essential items together in a high place.
- Collect things needed for evacuation.
- Stack sandbags, if possible, to form a barrier to hold back or redirect moving water from critical areas.
- Turn off gas, electricity and water supply if it is safe to do so.
- Avoid electricity sources.
- Avoid walking or driving through flood water.

## Weather and Natural Disasters, continued

### Thunderstorm and Lightning Safety

A lightning bolt carries up to 100 million volts of electricity. When someone is struck by lightning, an electrical shock occurs that can cause burns and even stop the person's breathing. Although thunder and lightning can occur occasionally during a snowstorm, April to October are the prime thunderstorm months in Canada. Thunderstorms occur most often in late afternoon or evening, and around sunrise.

Knowing how lightning behaves can help you plan for an approaching storm. It tends to strike higher ground and prominent objects, especially materials that are good conductors of electricity, such as metal. Thunder can be a good indicator of lightning - loud crackling means its close, whereas rumbling means the storm is further away.

Because light travels faster than sound, you will see lightning before you hear the thunder. Each second between the flash and the thunderclap represents about 300 metres. If you can hear thunder, you are within striking distance. Immediately go inside, there is NO safe place to be outside in a thunderstorm.

Protection from lightning begins before the storm. Paying attention to weather conditions and forecasts allows time to plan for threatening weather and to react appropriately.

#### What to do during a thunderstorm

The safest place to be during a thunderstorm is in a building that is fully enclosed with a roof, walls and floor with electrical wiring, plumbing, telephone line, or antennas to ground the lightning should the building be hit directly. Unsafe shelters are buildings or structures without electricity or plumbing to ground the lightning, as they do not provide any lightning protection. Shelters that are unsafe include covered picnic shelters, carports, tents, baseball dugouts as well as other small non-metal buildings (sheds and greenhouses).

Even when inside the building, there are safety precautions to take:

- Keep as many walls as possible between you and the outside. Stay away from doors, windows, and fireplaces.
- Stay away from anything that will conduct electricity such as radiators, stoves, sinks and metal pipes.
- Use battery operated appliances only. Avoid handling electrical appliances and regular telephones (cordless phones and cell phones do not increase the risk of a lightning strike).

The next best place for shelter is an enclosed metal car, truck or van but NOT a tractor, golf cart, topless or soft-top vehicle. Make sure the vehicle is not parked near trees or other tall objects that could fall over during a storm. When inside a vehicle during a lightning storm, roll up the windows and sit with your hands in your lap and wait out the storm. Don't touch any part of the metal frame or any wired device in the vehicle (including the steering wheel or plugged-in cell phone). A direct strike to your car will flow through the frame of the vehicle and usually jump over or through the tires to reach ground.

#### What to do if you cannot find shelter

There is no safe place to be outdoors during a thunderstorm. However, to reduce the risk of being struck by lightning when outside, stay away from things that are tall (trees, flagpoles or posts), water, and other objects that conduct electricity (tractors, metal fences, lawn mowers, golf clubs). Do not become a target by being the highest object on the landscape. If you are with a group of people in the open, spread out several metres apart from one another.

If you get caught in a level field far from shelter, crouch down on the balls of your feet immediately, with feet together, place your arms around your knees and bend forward. Be the smallest target possible, and at the same time, minimize your contact with the ground. Don't lie flat.

---

## Weather and Natural Disasters, continued

If someone has been hit by lightning

Lightning victims are safe to touch. Bystanders shouldn't hesitate to save a life by calling for help. If breathing has stopped, administer mouth-to-mouth resuscitation. If the victim is not breathing or they do not have a pulse, a trained rescuer should administer cardiopulmonary resuscitation (CPR).

### Tornados

A tornado is nature's most violent form of storm activity. It can produce upwardly spiraling winds of 120 to 450 km/h, producing devastating damage along a path of 50 to 300 metres in width. The forward motion of the tornado funnel may be quite erratic as it zigzags along a southwest to north-easterly direction (usually) at a forward speed of 50 to 70 km/h.

Hot, humid weather combined with a cold front could be a sign that a tornado is brewing, and a funnel cloud hanging from a dark cloud may be visible before the tornado actually occurs (a funnel cloud is not a tornado until it touches the ground). The sound has been described as a tremendous roar which sounds like an express train or jet aircraft (only louder). Clouds may be green or yellow tinged. There is usually a noticeable lowering of a portion of the cloud that contains a large, swirling, turbulent mass from which the funnel will hang (funnel cloud).

### Protecting yourself during a tornado

- Have a radio on to listen for warning information or advice.
- Determine an appropriate shelter (select a shelter area that would offer protection, such as underneath a stairway and is secured to the main floor). The shelter must be easily accessible and able to offer protection from flying glass, debris and furniture. (Decide on shelter options in advance, for your place of employment.) If forced to take shelter away from the plant avoid large halls or any large building with large span roofs. Seek out an inner hallway, washroom, closet, etc.
- Stay away from windows.
- Avoid travelling any great distance so that you will not be caught out in the open.
- If the storm warning is issued for your immediate area, go to your designated shelter.
- If caught outdoors and you cannot reach shelter, lie flat in a ditch, excavation or culvert. If possible, lay flat, holding the base of a small tree, bush or shrubbery to avoid being lifted or blown away.
- If caught while driving, drive away from the funnel at a right angle or to its direction of travel (if possible). If you cannot escape the path of the funnel, get out of your vehicle immediately and seek shelter in a ditch or ravine, keeping its slope between you and the funnel.
- If caught away from the plant, seek shelter in a sturdy building. Go to an interior hallway or washroom on the lower floor, and stay away from windows.

## Winter Storms: Blizzards, Freezing Rain, Heavy Snow, Blowing Snow

### General Information

Blizzards come in on a wave of cold arctic air, bringing snow, bitter cold, high winds, and poor visibility in blowing snow. These conditions must last for a minimum of six hours to be designated a blizzard and they may last for several days. Poor visibility, low temperatures and high winds constitute a significant hazard.

## Weather and Natural Disasters, continued

Freezing rain occurs when the air in an upper-air layer has an above-freezing temperature, while the temperature at the surface is below freezing. The snow that falls melts in the warmer layer; as a result, it is rain—not snow—that lands on the surface. But since the temperature is below 0°C, raindrops freeze on contact and turn into a smooth layer of ice. More slippery than snow, freezing rain is tough and clings to everything it touches. A bit of freezing rain is dangerous; a great deal of it can be catastrophic.

### Things to do during a severe winter storm or if a storm is forecast

- Stay calm and leave your radio on to stay informed of the situation and hear updated forecasts.
- Stay indoors. If you must go out, dress for the weather.
- Secure everything that might be blown around or torn loose – indoors and outdoors (flying objects can injure people and damage property).
- If you are outdoors when a storm hits, take shelter immediately.

Winter Weather Warnings	Issued
Blizzard Warning	When winds of 40 km/hr or greater are expected to cause widespread reductions in visibility to 400 metres or less, due to blowing snow, or blowing snow in combination with falling snow, for at least 4 hours.
Freezing Rain Warning	When freezing rain is expected to pose a hazard to transportation or property; or when freezing rain is expected for at least 2 hours.
Snowfall Warning	When 10 cm or more of snow is expected to fall within 12 hours.
Wind Warning	70 km/h or more sustained wind; and/or Gusts to 90 km/h or more.
Wind Chill Warning	<p>Issued to warn of conditions that will cause frostbite to exposed skin. Criteria vary across the country, ranging from wind chill values of -55 in some Arctic regions to -30 in South-western Ontario. A national wind chill program is in development.</p> <p>For wind chill values:</p> <p>-27 to -44 ...risk of frostbite and risk of hypothermia increases with time spent outdoors</p> <p>-45 or lower ...exposed flesh may freeze in minutes and there is a serious risk of hypothermia</p>
Winter Storm Warning	<p>When severe and potentially dangerous winter weather conditions are expected, including:</p> <p>A major snowfall (25 cm or more within a 24 hour period); and</p> <p>A significant snowfall (snowfall warning criteria amounts) combined with other cold weather precipitation types such as: freezing rain, strong winds, blowing snow and/or extreme wind chill.</p>

Source: Environment & Climate Change Canada (ECCC), Public Alert Criteria

<http://www.ec.gc.ca/meteo-weather/default.asp?lang=En&n=D9553AB5-1>

---

## Weather and Natural Disasters, continued

### After a Disaster

These are general guidelines to look for after an occurrence:

- Assess site and declare an emergency as required.
- Activate ERP as required.
- Account for all on-site and field personnel.
- Listen to a battery-operated radio or television for the latest emergency information.
- Give first aid to the injured and call for medical assistance if required. Do not move seriously injured persons unless they are in immediate danger of further injury. Use intrinsically safe flashlights to survey for damage and look for victims. Do not use candles or matches (explosion hazards may exist).
- Use the telephone for emergency calls only.
- Check for spilled medicines, bleaches, gasoline or other flammable liquids.
- Open cabinets cautiously. Beware of objects that can fall off shelves.
- Report fires to the fire department. Be alert to prevent fires, as broken water mains may cause a reduction in water pressure. Lightning and downed power lines can cause fires. Know how to fight small fires.
- Inspect utilities.
  - Look for electrical system damage. If you see sparks or broken or frayed wires, or if you smell hot insulation, turn off the electricity at the main fuse box or circuit breaker. Do not go near loose or dangling power lines. If you have to step in water to get to the fuse box or circuit breaker, call an electrician first for advice.
  - Check for sewage and water lines damage. If you suspect sewage lines are damaged, avoid using the toilets and call a plumber. If water pipes are damaged, contact the water company and avoid using water from the tap. You can obtain safe water by melting ice cubes.
  - Check for leaking pipes. If you smell sour gas:
    - Immediately evacuate the area and don appropriate personal protective equipment.
    - Close gas valves and isolate the area.
    - Turn off the main power switch (only if you are NOT wet or standing in water).
    - Shut down required plant and well sites and notify appropriate government authorities.
    - Check buildings prior to entering as there may be structural damage; proceed cautiously.
- In the case of a flood, proper cleanup is essential. Discard all materials that cannot or should not be saved. Wash and rinse all surfaces, then disinfect them. Remove any water as soon as possible and clean out mud and other debris. Water supplies may be contaminated; use caution with drinking water.
- In the case of an earthquake, expect aftershocks. These are usually less violent than the main quake but can be strong enough to do additional damage to weakened structures and can occur in the first hours, days, weeks, or even months after the quake.

*Note: The emotional impacts of disasters on those affected can be distressing and lasting, even if it doesn't involve physical harm. Help by maintaining a positive attitude and a sense of calmness. Your local health authority can assist in coping with trauma resulting from a disaster.*

This page is intentionally left blank

## Security Incidents

A security incident is a security-related occurrence, threat or action that has adversely affected people, the environment, assets, and economic stability, or could potentially do the same.

### General Notes on Prevention of Security Incidents

As defined in the CSA Standard Security Management for Petroleum and Natural Gas Industry Systems (Z246.1-21), a Security Management Program should be implemented to ensure security incidents and threats are identified and managed with appropriate safeguards and response procedures in place.

This documented security risk management process should incorporate threat, vulnerability, risk assessment and asset characterization. Asset characterization, in particular, identifies and ranks any assets that could result in adverse consequences if damaged or destroyed.

To minimize the possibility of threats within a company property, an adequate physical security system must be in place. This should include the following:

- Perimeter fencing and gates to protect against unauthorized entry into a facility – gates should be closed when not in use and locked when unoccupied
- Appropriate signage at the perimeter and entrances
- Intrusion detection systems / alarm systems
- Sufficient lighting in darkness or areas of poor visibility
- Pedestrian access control
- Security guard force, both static and mobile
- Employee awareness

### Types of Security Threats

Security-related threats have the intent to cause harm and could include bomb threats, suspicious packages, terrorism, vandalism, trespassing and cyber-attacks.

### Responding to Threats

Should any facility or office be the subject of a threat or be advised of the potential of a terrorist attack, or of the potential of an attack to an adjoining facility being operated by another company, the person receiving the initial threat should remain calm, document all information in writing and notify his supervisor immediately. The supervisor should make an immediate assessment of the circumstances then:

- Obtain all data from the person who received the threat.
- If there is clear and imminent danger, the plant should be immediately evacuated, and the Field Response Team activated from a remote location.
- Contact local police / Royal Canadian Mounted Police (RCMP).
- Notify the Regulatory Agency and the Incident Commander.

## Security Incidents, continued

Once the Field Response Team is activated, the Field Response Team Incident Commander and a senior company representative will consider the threat and options available to respond to the threat. There are a myriad of potential short and long term responses available and they will be dependent on the evaluation of the threat, time available to respond, resources available locally or that can be brought in a reasonable time, and police and military resources available.

- If the threat is considered possible, the Canadian Security Advisor recommends that the following immediate/short term responses should be considered:

### Field Operations:

- Establish intelligence liaison with local authorities (e.g. police).
- Report all suspicious activity to Corporate Security.
- Discontinue all site tours and visits.
- Restrict vehicle access to specifically authorized vehicles only.
- ID all visitors seeking access.
- Assign a person to patrol the perimeter of the facility at the beginning of each operational shift and note any deficiencies; look for signs of attempted break and enter.
- Conduct an evacuation exercise.

### Remotely Operated Facilities (also applies to any facility operated by a single person):

- Establish full lock down on fences and assets on the lease/site – everything that can be secured and locked is secured and locked.
- Conduct a fence perimeter patrol before entering the site – look for signs of illegal entrance.
- Conduct a full exterior building patrol before entering a building – look for signs of unlawful entrance (doors pried, windows open, broken glass etc.).
- When working, lock the gates upon entering and leaving the facility, and rigidly adhere to the work alone guidelines.

## Bomb Threats

Bomb threats are delivered in a variety of ways. The majority of threats are called in to the target, though occasionally these calls are through a third party. Sometimes a threat is communicated in writing, or by a recording.

Persons making bomb threats generally have one of two motivations:

1. The caller has definite knowledge or believes that an explosive or incendiary bomb has been, or will be, placed. He or she wants to minimize personal injury or property damage. The caller may be the person who placed the device or someone who has become aware of such information.
2. The caller wants to create an atmosphere of anxiety and panic which will, in turn, result in a disruption of the normal activities at the location where the device is purportedly placed.

While most bomb threats are unfounded, some are not. As such, each one must be dealt with as though it is real and handled seriously and calmly.

## Security Incidents, continued

### Bomb Appearance

Bombs can be constructed to look like almost anything and can be placed or delivered in any number of ways. The probability of finding a bomb that looks like the stereotypical bomb is almost non-existent. Most bombs are homemade and are limited in their design only by the imagination and resources available to the bomber.

Remember, when searching for a bomb, suspect anything that looks unusual. Ultimately, however, let a trained bomb technician determine what is or is not a bomb.

### Responding to Bomb Threats over the Phone

Most threats or implied threats are received by telephone, generally at a publicized or switchboard number. Should that occur, obtain as much information as possible, filling out the Threatening Call / Bomb Threat form (**Section 6: Forms**).

If a bomb threat is received over the telephone, the employee receiving the phone call should take the following actions:

- Stay calm and keep their voice calm.
- Pay close attention to details. Write information down as the caller says it. Attempt to get the following information from the caller:
  - What type of bomb is being used?
  - Did you place the bomb?
  - Who is the target?
  - Where has the bomb been placed?
  - What time is the bomb set to explode?
  - Why was the bomb placed?
  - What type of container is the bomb placed in?
  - What does it look like?
  - What is the bomber's name?
  - What is the bomber's address?
- While the first employee is dealing with the threatening phone call, they should have a co-worker or another person contact the police (dial 911) using another telephone, and as covertly as possible. As the first employee writes down answers to the questions above, these answers should be relayed to the police.
- The call recipient should attempt to keep the caller on the phone.
- The call recipient should note the caller's:
  - Age and gender
  - Emotional state (angry, agitated, calm, etc.)
  - Speech patterns (accent, tone)
  - Background noise (traffic, people talking and accents, music, and type, etc.)

### Responding to Bomb Threats Received in Writing

If a threat has been received in writing, minimize the handling of the document to ensure preservation of forensic evidence - DO NOT PHOTOCOPY.

## Security Incidents, continued

### Supervisor Responsibilities after Receiving a Bomb Threat

The supervisor should then:

- Obtain all data from the person who received the threat
- Activate the ERP if the situation warrants
- Contact local police / Royal Canadian Mounted Police (RCMP) if this has not already been done
- Notify the Regulatory Agency
- Decide on partial or total evacuation (if needed)
- Decide on partial or total search of the facility (if needed)

### Evacuating the Facility

If it seems prudent to evacuate the building:

- Have all employees briefly check their work areas for unfamiliar items.
- Instruct all employees not to touch suspicious items, but simply to report them to their supervisors (taking pictures if feasible).
- Instruct all employees not to take personal belongings when they leave.
- Leave doors and windows open
- Do not to turn light switches on or off.
- Do not activate the fire alarm.
- Use stairs only; do not use elevators.
- Use of radio communications should be restricted as the signal could detonate a device.
- All evacuees should report to an outside pre-designated muster area for accountability.

### IED Evacuation Distances

Improvised Explosive Device (IED)  
SAFE STAND OFF DISTANCE

	Threat Description	Explosives Mass (TNT equivalent) <sup>1</sup>		Building Evacuation Distance <sup>2</sup>		Outdoor Evacuation Distance <sup>3</sup>	
High Explosives (TNT Equivalent)	Pipe Bomb	5 lbs	2.3 kg	70 ft	21 m	850 ft	259 m
	Suicide Belt	10 lbs	4.5 kg	90 ft	27 m	1,080 ft	330 m
	Suicide Vest	20 lbs	9 kg	110 ft	34 m	1,360 ft	415 m
	Briefcase/Suitcase Bomb	50 lbs	23 kg	150 ft	46 m	1,850 ft	564 m
	Compact Sedan	500 lbs	227 kg	320 ft	98 m	1,500 ft	457 m
	Sedan	1,000 lbs	454 kg	400 ft	122 m	1,750 ft	534 m
	Passenger/Cargo Van	4,000 lbs	1 814 kg	640 ft	195 m	2,750 ft	838 m
	Small Moving Van/ Delivery Truck	10,000 lbs	4 536 kg	860 ft	263 m	3,750 ft	1 143 m
	Moving Van/Water Truck	30,000 lbs	13 608 kg	1,240 ft	375 m	6,500 ft	1 982 m
	Semitrailer	60,000 lbs	27 216 kg	1,570 ft	475 m	7,000 ft	2 134 m

## Security Incidents, continued

### Bomb Search Guidelines

Employees must not touch anything - only law enforcement explosive disposal units or qualified private consultants are qualified to search for a bomb or suspicious package.

In the event of a search, however, employees may be called upon to unlock drawers, cabinets, and the like for the search crew, and to identify any strange or unfamiliar objects.

### Explosive Device Located

If a device or suspected device is located:

- Do not touch or move the object.
- Evacuate the immediate area.
- If possible, take steps to minimize effects of an explosion in the vicinity by evacuation or isolation of the area.
- Ensure RCMP are apprised of the location so explosive disposal unit can be called.

### If there is an Explosion

- Have employees take cover under sturdy furniture or leave the building if directed to do so by emergency responders.
- Stay away from windows.
- Do not light matches.
- Move well away from the site of the hazard to a safe location.
- Use stairs only; do not use elevators.
- Call 911 if no one has called.

### Suspicious Packages

The likelihood of receiving a bomb in the mail is remote. Unfortunately, however, a small number of explosive devices have been mailed over the years resulting in death, injury, and destruction of property.

A bomb can be enclosed in either a parcel or an envelope, and its outward appearance is limited only by the imagination of the sender. However, mail bombs have unique characteristics that may assist in identifying suspect packages.

## Security Incidents, continued

### Appearance of Suspicious Packages

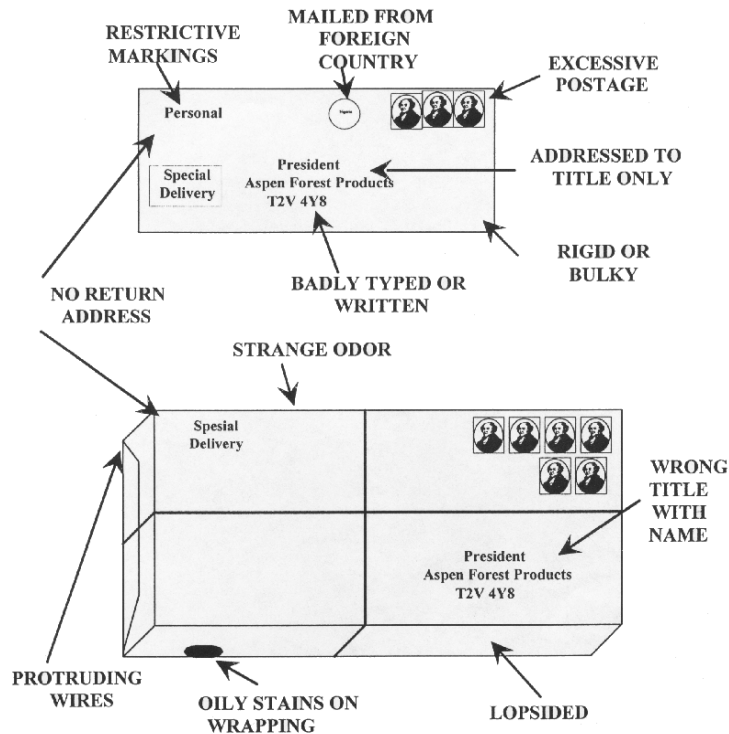

- Mail bombs may display restricted endorsements such as “Personal” or “Private”. This factor is important when the addressee does not usually receive personal mail.
- Addressee’s name / title may be inaccurate.
- Return address may be fictitious.
- Mail bombs may reflect / distort handwriting or the name and address may be prepared with homemade labels or cut-and-paste lettering.
- Cancellation or postmark may show a different location than the return address.
- Mail bombs may have excessive postage.
- Mail bombs may feel rigid or appear uneven or lopsided and may have an irregular shape, soft spots, or bulges.
- Parcel bombs may be unprofessionally wrapped with several combinations of tape used to secure the package and may be endorsed “Fragile – Handle With Care” or “Rush – Do Not Delay”.
- Parcel bombs may have a buzzing or ticking noise or a sloshing sound.
- Pressure or resistance may be noted when removing contents from an envelope or parcel.

## Security Incidents, continued

### Dealing with Suspicious Packages

If an employee is suspicious of a mailing and is unable to verify the contents with the addressee or sender:

- Do not open the article.
- Isolate the item and evacuate the immediate area.
- Do not put the package or envelope in water or a confined space such as a desk drawer or filing cabinet.
- If possible, open windows in the immediate area to assist in venting potential explosive gases.

If an employee suspects a harmful chemical or biological substance is in a package already on company property, they should:

- Cover the package or envelope with a plastic sheet, raincoat, etc.
- Evacuate the room closing all doors and windows.
- Call their supervisor who will contact the local police.
- Isolate the area where the package is.
- Isolate themselves in another area that has a telephone and wait for the emergency responders to arrive.

If an employee has touched a package that possibly contains a harmful substance or got some on their clothes, they should:

- Wash their hands well.
- Shower with their clothes on
- Undress and seal their clothes in a plastic bag.
- Shower again and put on fresh clothes.

If an employee has any reason to believe a letter or parcel is suspicious, they should never take a chance or worry about possible embarrassment if the item turns out to be innocent.

## Trespassing

Any person who enters land where entry is prohibited or does not leave land immediately after being directed to do so by the owner or occupier of the land is guilty of trespassing.

### Dealing with Trespassing

If any personnel encounter a trespasser:

- Ask the trespasser to leave the unauthorized area.
- Give the trespasser a reasonable amount of time to leave peacefully.
- If the trespasser refuses to leave, call the RCMP / local authority.

## Security Incidents, continued

### Vandalism

Vandalism is the willful damaging or defacing of property belonging to another person or to the public. Acts of vandalism can include:

- **Defacing** – removing, marking, or damaging a part of an object to draw attention to it.
- **Criminal damage** – willful and unlawful destruction of other people's property.
- **"Tagging" or graffiti** – gangs use "tags" to mark their territory and usually spray-paint walls and doors of homes and business establishments.

Vandalism can happen at any time of the day or night and in any season, but it most often occurs:

- In the evening during summer and fall
- On weekday evenings
- At night when fewer people are around, and the property isn't under as much scrutiny
- Where building design and lighting offers concealment and anonymity
- In areas frequented by young people such as schools, parks, shopping plazas and public buildings
- In unoccupied buildings, open spaces, or parked vehicles where minimum surveillance is given to property

### Dealing with Vandalism

- Report all incidents of vandalism to a supervisor
- Do not paint over vandalism and graffiti until the police department gives clearance to do so.

### Terrorism

Terrorism is the use of violence and threats against persons or property for the purposes of intimidation, coercion, or ransom. The direct targets of violence are not the main targets of a terrorist but a means to draw the attention of the local populace, the government, and the world to their cause. A terrorist group commits acts of violence to:

- Produce widespread fear
- Obtain worldwide, national, or local recognition for their cause by attracting the attention of the media
- Destroy facilities or disrupt lines of communication in order to create doubt that the government can provide for and protect its citizens
- Discourage foreign investments, tourism or assistance programs that can affect the target country's economy and support of the government in power
- Influence government decisions, legislation, or other critical decisions
- Satisfy vengeance

Acts of terrorism include threats of terrorism, assassinations, kidnappings, hijackings, bomb scares and bombings, cyber-attacks, and the use of chemical, biological, nuclear, and radiological weapons.

## Security Incidents, continued

### Examples of Petroleum Assets Subject to Risk

- Buildings: Administration offices, corporate offices, control rooms
- Equipment: Process units and associated control systems, product storage tanks, surge vessels, boilers, turbines, process heaters, sewer systems
- Support Systems: Utilities such as natural gas lines, electrical power grid and facilities (including back-up power systems), water-supply systems, wastewater treatment facilities
- Transportation Interfaces: Railroad lines and railcars, product loading racks and vehicles, pipelines entering and leaving facility, marine vessels and dock area, off-site storage areas
- Cyber systems and information technology: Computer systems, networks, all devices with remote maintenance ports, SCADA systems, laptops, PDAs, and cell phones.

### Dealing with Terrorism

All threats and incidents should be reported to the RCMP Terrorism Tip Line at 1-800-420-5805.

In order to deal with threats of terrorism, it is important to establish a security management system to effectively manage security risks. This system should include a security risk management process incorporating asset characterization, threat assessment, vulnerability assessment, risk assessment, risk mitigation, communication, and recommendations.

This system should be reviewed at regular intervals and updated as necessary.

### Cyber-Attacks

Cyber-attacks are computer-to-computer attacks that undermine confidentiality, integrity or availability of a computer or the information contained.

Cyber-attacks can make computer systems malfunction or result in a disrupted flow of data and have the potential to create extreme economic damage.

This threat includes a risk to SCADA and DCS systems, which collect, display, and store information in support of controlling equipment, devices, and facilities.

### Preventing Cyber-Attacks

Steps that can be taken to enhance your cyber security:

- Know who owns and operates the IT system and its operating framework.
- Map the network – include all internal/external connections, configuration control, etc.
- Develop a security policy structure and implement compliance monitoring.
- Apply as much security and hardening as appropriate.
- Accredite the IT system and follow a risk management approach.
- Know the system's possible vulnerabilities.
- Patch the system in a timely manner – the longer this is delayed, the longer the system is vulnerable.
- Reduce Internet access points.
- Reduce or eliminate potential sources of infection – USB flash drives (thumb drives, USB keys, etc.), flash media, etc.

## Security Incidents, continued

- Communicate, train, and educate staff and users.

*Source: 10 IT Security "Commandments" - Communications Security Establishment Canada*

### Dealing with Cyber-Attacks

In the event of a cyber-incident:

- After obtaining corporate approval, local police or RCMP should be notified.

Serious cyber incidents:

- Should be reported to Public Safety Canada by email at [contact@cyber.gc.ca](mailto:contact@cyber.gc.ca) or by phone at 1-833-292-3788.

## Animal Encounters

### First Responders to Animal Attacks

In the event of witnessing or identifying a scene as an attack, it is important to avoid harm to yourself. If equipped with deterrents, an attempt to scare away any remaining animals on scene is optional. In most cases any animals who have recently engaged in an attack are unpredictable therefore it is advised to keep clear and wait until the scene is clear. Steps to be considered:

- Assess the immediate area for personal safety and determine the type of incident
- If cause of injury is unknown, use your gas monitor to ensure there aren't any air-borne hazards.
- Ensure all animals have vacated the scene.
- If not, use any available noise deterrents (Honk Horn, Rev Engine, yell etc.)
- If possible call or radio for assistance and emergency services.
- Calling an applicable wildlife agency is an effective alternative; however, if confronted with a fast paced scenario such as this, the RCMP will be able to direct your call appropriately.
- Once the area is safe, assess the individuals' injuries and administer any necessary first aid. If the victim is conscious, always ask for his/her consent before doing so.
- Stay with the victim until help arrives:
  - As shock to the victim may be a factor after an attack, using a calm voice and catering to the individuals' requests as best possible is beneficial. For example; covering the victim with a blanket, providing drinking water for the victim, ensuring the victim that help is on the way, etc.
  - Minimize the victim's movements until emergency services have arrived as the extent of harm to the individual is unknown until assessed by a licensed health care representative.
- It is important to document the time and actions taken if a scenario like this presents itself as it will aid you and your company in showing what actions have been taken and how the situation has been responded to.
- Notify your supervisor of the incident.
- You or your supervisor must contact the applicable wildlife regulatory agency to report the incident.

## Animal Encounters, continued

### Bears

There are no hard and fast rules about what to do when you confront a bear. Bears react to humans in different ways in different situations. A bear's reaction depends on the following: sex, age, health; the season; whether the bear is hungry; whether bear cubs are present or whether there is an escape route available to the bear. Never harass or chase a bear!

There are three possible scenarios that are most likely to occur:

1. **A wandering bear.** While it is unlikely that a bear will wander into an area and near workers, we must be prepared to deal with this situation. Any bear seen on the job site will cause an immediate notification of the Incident Commander. In addition, all workers within 500 metres of the animal are to seek immediate shelter within a vehicle or building. The Incident Commander shall assess the situation, observe the bear for its intent, and determine a proper course of action to be taken. At no time will the bear be approached by any workers for any reason other than at the direction of the Incident Commander.
2. **A located occupied den.** A den occupied by a bear will cause an immediate cessation of work and removal of personnel within 500 metres of the den and notification of the Incident Commander. At the discretion of the Incident Commander, the appropriate Environment Fish and Wildlife agency may be notified to determine the best course of action to be taken.
3. **Denning bear disturbed.** The company understands that disturbing a hibernating bear is unsuitable for both the bear and for the workers. Upon discovery or disturbance of a hibernating bear all workers will immediately retreat from the area to a distance of not less than 500 metres and into immediate shelter within a vehicle or building. This situation will cause an immediate notification of the Incident Commander.

### On the Trail

Bear encounters on the trail can be dangerous, especially if the bear is surprised or if it is a female with cubs. The bear may consider you a threat and either run away or attempt to remove you as a threat. If you encounter a bear on a trail:

- Stop! Try to stay calm and quiet. Do not make any sudden moves or loud noises. Avoid direct eye contact with the bear; however, never take your eyes off the bear.
- Size up the situation. Is it a black bear or a grizzly? Are there cubs present and where are they in relation to you and the bear? Did you disturb the bear during feeding? Where is the rest of your party? (Always stay together as a group; a bear is less likely to attack a group of people than an individual).
- Do not run from the bear. You cannot out run it! Black bears can reach speeds of 55km/hr.
- Talk quietly and slowly back up leaving the way you came; give the bear enough time and room to leave on its own. Invading the bears space will invoke its "fight or flight" response. Grizzly bears are most likely to fight while Black bears are most likely to choose flight. Avoid any rapid movements and move up wind so the bear can catch your scent and determine you are not a threat.
- If the bear keeps coming at you, climb the tree as high as you can. Remember, some grizzlies and all black bears can climb trees; but if you climb a tree the bear may feel less threatened.

---

## Animal Encounters, continued

### In Case of Attack (general)

Try to defend yourself on a steep slope or grade; in doing so, you can ensure that any bear will at least have a difficult time standing erect, thereby reducing his full weight force. Bears are also front-heavy, creating an offset in balance when downing slopes or grades.

- Do not run from the bear. You cannot out run it. A bear will often make a "bluff" charge, in which it turns away at the last moment. Running away from such a charge will trigger a more aggressive attack.
- If the bear continues the attack, spray bear ("pepper") aerosol in the animal's eyes. This may cause the bear to stop the attack, and give you an opportunity to escape.

*Note: Bear spray must be kept on your person within easy reach or it will not be of use. Bear spray is not a repellent, but a weapon that is only effective in the animal's eyes and nose. It will not repel bears from a sprayed area. In fact, there is evidence to suggest that bears are attracted to objects covered with pepper spray. Read the instructions, understand how to use the spray, and test it to be sure of its range and accuracy.*

- If no escape is possible and the bear has knocked you to the ground—roll yourself into a "cannonball" position and play dead. Cover your neck and head with your hands and arms. Stay in this tucked position until the bear leaves.
- If a black bear is attacking you, or you are attacked at night by either species, consider it a predatory attack and fight back with everything you have.

### Defensive Attack

- Bears will engage in a defensive attack when feeling threatened or cornered. This type of attack occurs when a bear is protecting her young, or the carcass of its latest kill. The bear will show signs of stress, like huffing, pawing the ground, exposing its teeth, body swaying and pinning its ears back. The bear in this type of attack will often make "bluff" charge, in which it will turn away at the last moment or veer off its path.
- In this type of attack, play dead to show the bear you are not a threat.
  - If wearing a pack, leave it on for protection
  - Lie face down on the ground, legs splayed (spread) so the bear cannot easily turn you over
  - If rolled over, quickly turn back onto stomach
  - Clasp hands around the back of your neck
  - Do not shout or act aggressive
  - Remain quiet and still
  - Be prepared to wait until the bear realizes you are not a threat.
- If the bear continues to attack, fight for your life, aiming your assault at the bears head, nose and eyes.

### Predatory attack

- Bears will show no signs of stress during this type of attack. The bear will stalk you and swiftly attack without a warning or "bluff" charge.
- In this type of attack, act aggressive to show the bear you will not be easy prey
  - Do not be submissive
  - Face the bear, never taking your eyes off of it

## Animal Encounters, continued

- Don't attempt to run away
  - Scan for any near-by cover and possible weapons (stick and stones)
  - Prepare your deterrent
  - Make yourself as large as possible
  - Raise your arms and stomp your feet
  - Use rapid arm and leg movement
  - Shout loudly
  - Remove your pack
  - DO NOT PLAY DEAD
- If the bear continues to attack, fight for your life, aiming your assault at the bears head, nose and eyes.

### In Camp

Bears entering a camp may be coming to feed on human food and garbage, based on their past experiences in camps. Such bears are especially dangerous because they have become human habituated and no longer fear people. It is important if a bear wanders into your campsite to provide it with a negative stimulus to prevent it from returning and becoming human habituated (screaming, noise deterrents etc.). If your campsite is clean, with all attractants properly stored, a bear may lose interest and move on. If a bear comes into your camp, refer to the points in ON THE TRAIL. If your vehicle is nearby, get in it as soon as possible.

### Cougars

Conflict between cougars and humans is extremely rare. Although a cougar attack is highly unlikely, it always pays to be prepared. Information and awareness are your best defenses.

- Cougars are most active at dusk and dawn. However, they will roam and hunt at any time of the day or night and in all seasons.
- During late spring and summer, one to two-year old cougars become independent of their mothers. While attempting to find a home range, these young cougars may roam widely in search of unoccupied territory. This is when cougars are most likely to conflict with humans.
- Cougars have four toes with three distinct lobes present at the base of the pad. Claws are retractable, so they usually do not leave imprints.
- Generally, cougars are solitary. If tracks show two or more cougars traveling together, it probably indicates a female with cubs.
- Cougars seem to be attracted to children, possibly because their high-pitched voices, small size, and erratic movements make it difficult for cougars to identify them as human and not as prey.

### Cougar Safety

- Avoidance is the best line of defense.
- Keep a radio playing.
- Do not attract or feed wildlife, especially deer or raccoons. These are natural prey and may attract cougars.
- Roaming pets are easy prey.

## Animal Encounters, continued

- Bring pets in at night. If they must be left out, confine them in a kennel with a secure top.
- Do not feed pets outside. This not only attracts young cougars but also many small animals, such as mice and raccoons, that cougars prey upon.
- Place domestic livestock in an enclosed shed or barn at night.
- Hike in groups of two or more. Make enough noise to prevent surprising a cougar.
- Carry a sturdy walking stick to be used as a weapon.
- Watch for cougar tracks and signs. Cougars cover unconsumed portions of their kills with soil and leaf litter. Avoid these food caches.
- Cougar cubs are usually well hidden. However, if you do stumble upon cougar cubs, do not approach or attempt to pick them up. Leave the area immediately, as a female will defend her young.

### If You Meet a Cougar

- All cougar encounters should be considered predatory. Act big and confident. Make direct eye contact, be loud and attempt to intimidate.
- Never approach a cougar. Although cougars will normally avoid a confrontation, all cougars are unpredictable. Cougars feeding on a kill may be dangerous.
- Always give a cougar an avenue of escape.
- Stay calm. Talk to the cougar in a confident voice.
- Pick all children up off the ground immediately. Children frighten easily and their rapid movements may provoke an attack.
- Do not run. Try to back away from the cougar slowly. Sudden movement or flight may trigger an instinctive attack.
- Do not turn your back on the cougar. Face the cougar and remain upright.
- Do all you can to make yourself seem larger and as intimidating as possible. Don't crouch down or try to hide. Pickup sticks or branches and wave them about.
- Any cougar seen on the job-site will cause an immediate notification of the Incident Commander. In addition, all workers within 500 metres of the animal are to seek immediate shelter within a vehicle or building. The Incident Commander shall assess the situation, observe the cougar for its intent, and determine a proper course of action to be taken. At no time will the cougar be approached by any workers for any reason other than at the direction of the Incident Commander.

### If a Cougar Behaves Aggressively

- Arm yourself with a large stick, throw rocks, and speak loudly and firmly. Convince the cougar that you are a threat, not prey.
- If a cougar attacks, fight back! Many people have survived cougar attacks by fighting back with anything, including rocks, sticks, bare fists, and fishing poles.

Cougars are a vital part of our diverse wildlife. Seeing a cougar should be an exciting and rewarding experience, with both you and the cougar coming away unharmed. At the discretion of the On-Site Group Supervisor, the appropriate Environment Fish and Wildlife agency may be notified to determine the best course of action to be taken.

## Animal Encounters, continued

### Large Hooved Animals (Ungulates)

This family is comprised of several hooved omnivores common to Canadian lands. Unknown to most, ungulates cause more yearly fatalities than all predatory species combined. However, this is mainly due to vehicular accidents as opposed to acts of aggression. This class refers to:

- Bison
- Moose
- Mule and White tailed deer
- Elk
- Caribou

### Ungulate Safety

- Generally speaking they prefer not being near people.
- The best line of defense is avoidance.
- Although physical size and appearance varies significantly, temperaments have been noted to be fairly similar between most species of ungulate.
- Mating season for most ungulates is during the fall months with the young being born in the spring; at both of these periods females and particularly males will become more aggressive and territorial.
- Like all wildlife, keeping a safe distance and never feeding the animals is advised.

### If You Meet an Ungulate

The following 7 steps are suggested if experiencing a close encounter:

1. Avoid making similar noises, such as coughing, groaning, grunts, etc.
2. Do not approach the animal.
3. Stay calm and increase the distance between you and the animal while looking for an escape.
4. Run to safety once close enough.
5. Use noise deterrent if available.
6. Climb a tree if possible.
7. Report the incident to a work authority.

### If It Behaves Aggressively

If confronted by an ungulate that feels threatened by you, consider it to be a dangerous situation.

- Look for an avenue of escape.

If knocked down:

- Curl up in a ball, protect head and neck with arms, and remain as still as possible. This is known as the “cannonball” position.
- Do not try to escape until the animal has moved a safe distance away.

---

## Animal Encounters, continued

### Rattle Snakes

Most North American snakes aren't poisonous. Exceptions in Canada include the rattlesnake and very rarely the copperhead snake. Their bites can be life-threatening. Both have slit-like eyes and are known as pit vipers. Their heads are triangular, with a depression (pit) midway between the eye and nostril on either side of the head. Rattlesnakes can be easily identified by the "rattle" noise created from the last segment of their tale when shaken.

#### Rattlesnake Safety

- Wear over-the-ankle or calf high boots.
- Do not put your hands where you cannot see.
- Use a tool when turning over rocks or boards.
- Always step on rocks and logs, never walk over them.
- Avoid walking through dense brush. If you must use a long stick or branch to beat the brush.
- Be careful when stepping over doorsteps. Snakes like to crawl along the edge of buildings.

#### If You Meet a Rattlesnake

- Remain calm. Do not panic.
- Stay at least five feet from the snake. Give the rattlesnake respect and space. Give the snake plenty of room.
- Avoid touching any snake. Back away slowly. Most snakes avoid people if possible and bite only when threatened or surprised.
- Do not try to kill the snake. Doing so is illegal and greatly increases the chance the snake will bite you.
- Alert your supervisor and others in the area of its location and update any hazard maps. Advise them to use caution and to respect the snake. Keep children and pets away.

#### In the event of a snake bite

- Remain calm, and inactive. By becoming agitated, your heart beats faster and you increase the flow of blood to the affected area and increase the amount of toxin able to find its way into your tissues.
- Immobilize the bitten arm or leg, and stay as quiet as possible to keep the poison from spreading through your body.
- Remove jewellery before you start to swell.
- Position yourself, if possible, so that the bite is at or below the level of your heart.
- Cleanse the wound, but don't flush it with water, and cover it with a clean, dry dressing.
- Do not put ice or cold substances on the bite.
- Apply a splint to reduce movement of the affected area, but keep it loose enough so as not to restrict blood flow.
- Mark the size of the affected area with a pen to track its progression.
- Drink plenty of fluids to maintain blood volume and prevent shock
- Don't try to capture the snake, but try to remember its colour and shape so you can describe it, which may help identify the snake for treatment, or try to get a picture of it from a safe distance.

## Animal Encounters, continued

- Drive to a hospital or doctor's office ASAP, or have someone else drive. In the event you are several hours away from the nearest hospital, stay standing, stay hydrated, stay calm, and use a cell phone to call emergency responders.
- Do not make "X" incisions over the fang injuries or suck out the toxin. You will most likely cause excessive bleeding and/or additional necrosis (tissue death) and/or further infection from the germs in your mouth or surrounding environment.
- For shallow bite wounds, let it bleed out naturally. More blood will come out at first as generally there are anticoagulants in the venom. If a bite is deep enough to cause spurting blood (i.e. the strike hit a major artery and you're losing blood fast), immediately apply pressure to the wound and call emergency medical personnel.
- Do not use a tourniquet. While certain medical conditions still are helped with proper application of a tourniquet, these are few in number. In most cases, application of a tourniquet will cause necrosis and possibly elevate the need for amputation of the affected area distal to the heart. (a tourniquet is a tight encircling band applied around an arm or leg in an emergency to stop severe bleeding, e.g. tying a piece of cloth around your arm really tight) However, if treatment is more than 60 minutes away, using a constrictive band is advisable to prevent spread of the toxin. The band should be placed 5-10 cm above the bite and you should be able to place 2 fingers under the band.
- Snakes typically do not exhaust their venom after the initial bite, so be sure to remove yourself from the area as quick as possible. Furthermore, snakes have been known to have a bite reflex last up to 60 minutes after death.
- Watch the victim for signs of shock. This is treated by lying flat with feet elevated. Cover with warm clothes or blankets.

## Wolves

Wolves generally avoid human interactions, unless they have become human habituated through repeated exposure to humans without any negative stimulus. It is not normal for wolves to attack or pursue humans. Please do your part to keep wolves where they belong, in the wild. As human population continues to grow, wolves are now considered an endangered species in Canada. In an attempt to keep wolves non-habituated, if seen, ensure all garbage has been properly disposed of and use noise to deter/scare the animal(s) away.

### Wolf safety

- Wolves are notoriously intelligent animals; generally hunting in groups or packs surrounding their prey.
- Wolves have ranges of up to 400km.
- Wolves may breed anytime throughout the year. However, pups are mainly born between April-June at which time the entire pack will aggressively defend their young.
- Wolves are considered timid towards humans. Attacks are more likely if a wolf feels threatened, is sick, or assess their prey maybe injured and therefore more susceptible to attack.
- Secure all food items and never feed any other wildlife. Deer and small mammals can attract larger predators such as wolves.
- Howling is a form of communication for wolves. If heard within a close proximity, it is advised to find shelter in a vehicle or building.

---

## Animal Encounters, continued

### If you meet a wolf

In the unlikely event of a wolf or wolves threatening humans, here is what to do.

- Stay calm
- Never make sudden movement; back away slowly, never turning your back on the wolf.
- Leave the wolf an avenue of escape.
- Raise your voice and speak firmly.
- If the wolf continues to approach, wave your arms in an attempt to make yourself look bigger.
- Make use of any rocks, sticks, camping gear, fists, or feet to fend off an attack, Try to protect your neck and head from attacks.

### Finding a wolf carcass

Wolves are an endangered species; in the event of finding a wolf carcass, take these following steps:

- Do not disturb or move any evidence.
- If possible, cover the carcass with a secured tarp or blanket in an attempt to preserve it.
- Once reported to your supervisor, call the appropriate provincial wildlife agency as they will determine the best course of action to be taken.

## Bees and Wasps

The presence of native wild bees, and many species of wasps and hornets will be noted by all personnel working on the project.

Head-nets will be required PPE for all personnel when working in areas where large concentrations of bees, wasps, or hornets have been identified.

All personnel will inform the Incident Commander of any known allergy to, or past reaction to bee, wasp, or hornet stings.

### If a “nest” is detected:

- All personnel will leave the area immediately.
- Call in the location of the “nest” to the Incident Commander.
- The area will be flagged as a hazard and its location written down for marking on the hazard map.

### If a sting or attack occurs the following procedure will be followed:

- Remove the stinger within 30 seconds if possible.
- Do not squeeze the wound as this will release more venom.
- Wash the wound with soap and water.
- Apply cold pack.
- Watch for any of these signs and symptoms of allergic reaction and notify Incident Commander immediately if detected: rash, tightness of the chest and throat, swelling of the face, neck, and tongue, excessive sweating, dizziness, and / or difficulty breathing.

## Animal Encounters, continued

### EpiPens

Adrenaline (epinephrine) is a natural hormone released in response to stress. It is a natural "antidote" to the chemicals released during severe allergic reactions triggered by drug allergy, food allergy or insect allergy. It is destroyed by enzymes in the stomach, and so needs to be injected. When injected, it rapidly reverses the effects of a severe allergic reaction by reducing throat swelling, opening the airways, and maintaining blood pressure.

Use of adrenaline for treating anaphylaxis is First Aid.

**IMPORTANT:** The information provided is of a general nature and should not be used as a substitute for professional advice. If you think you may suffer from an allergic or other disease that requires attention, you should discuss it with your Incident Commander.

#### Warning / direction for EpiPen use:

- Never put thumb, fingers, or hand over the orange tip. (Tip colours vary by brand. Other colours are generally black and green.)
- Do not remove grey safety release until ready to use.
- Do not use if solution is discoloured or red flag appears in clear window as it may be expired.
- Do not place any other foreign objects in carrier with auto-injector, as this may prevent you from removing the auto-injector for use.

#### Steps for EpiPen use:

1. Unscrew the yellow or green cap off of the EpiPen carrying case and remove the EpiPen auto-injector from its storage tube.
2. Grasp unit with the black tip pointing downward.
3. Form fist around the unit (black tip down).
4. With your other hand, pull off the gray safety release.
5. Hold black tip near outer thigh.
6. Swing and jab firmly into outer thigh until it clicks so that unit is perpendicular (at a 90° angle) to the thigh. (Auto-injector is designed to work through clothing.)
7. Hold firmly against thigh for approximately 10 seconds. (The injection is now complete. Window on auto-injector will show red.)
8. Remove unit from thigh and massage injection area for 10 seconds.
9. Call for Help and seek immediate medical attention.
10. Carefully place the used auto-injector (without bending the needle), needle-end first, into the storage tube of the carrying case that provides built-in needle protection after use. Then screw the cap of the storage tube back on completely, and take it with you to the hospital emergency room.

Most of the liquid (about 90%) stays in the auto-injector and cannot be reused. However, you will have received the correct dose of the medication if the red flag appears in window.

#### Immediately after EpiPen use:

- Go immediately to the nearest hospital emergency room or call 911. You may need further medical attention. Take your used auto-injector with you.
- Tell the doctor that you have received an injection of epinephrine in your thigh.
- Give your used EpiPen to the doctor for inspection and proper disposal.

# Section 5: External Agencies

Provincial Notification Matrix

Provincial Lead Agency Roles

Government Consultation Summary

Specific Government Agency Roles

    Health Services

    Local Authority

Provincial Supporting Agency Roles

Federal Agency Roles

---

This page is intentionally left blank

---

# British Columbia

## Notification Requirements for Key Government Agencies

Incident Type	Initial Responders								Lead Agencies				Supporting Agencies & Other Government Contacts						
	Agency of Resource	Ambulance Services	Local Fire Department	RCMP - Royal Canadian Mounted Police 1	EMCR - Ministry of Emergency Management & Climate Readiness 2	BCER - BC Energy Regulator 3	Local Authorities 4	Northern Health Authority	CER - Canada Energy Regulator 5	WorkSafe BC 6	MOE - Ministry of Environment 7	Technical Safety BC 8	ECCC - Environment Canada	MOTT - Ministry of Transportation & Transit	PSPC - Public Services and Procurement Canada	CANUTEC	ERAC - Emergency Response Assistance Canada	DFO - Department of Fisheries and Oceans	IOGC - Indian Oil & Gas Canada
Sour Gas / HVP Release (Uncontrolled)	a	✓	✓	✓	✓	✓	✓	✓	✓	✓	✓	c	d						g
Chlorine Gas Release	a	✓	✓	✓	✓	✓	✓	✓	✓	✓	✓	c	d	e					g
Sweet Combustible Gas Release	a	✓	✓	✓	✓	✓	✓	✓	✓	✓	✓	c	d						g
Spills / Transportation Incidents (Unrefined Products)**	a	✓	✓	✓	✓	✓	✓	✓	✓	✓	✓	c	d	e					g
Spills / Rail or Trucking Incidents (Refined Products)**	a	✓	✓	✓	✓	✓	✓	✓	✓	✓	✓	c	d	e	f				g
Serious Injury or Death as a Result of Oil & Gas Activity	✓	✓	✓	✓	✓	✓	✓	✓	✓	✓	✓								
Missing Person		✓					✓												
Fire / Explosion / B.L.E.V.E.	✓	✓	✓	✓	✓	✓	✓	✓	✓	✓	✓	c	d						g
Pressure Vessel or Piping Incident		✓			✓		✓		✓	✓	✓								
Electrical Incident		✓			✓		✓		✓	✓	✓								
Motor Vehicle Accident (Serious Injury or Death)	✓		✓					✓						d					
Motor Vehicle Accident (No injuries)		✓																	
Security Incidents																			
On - Site Incident Involving E2 Regulated Substance	a	✓	✓	✓	✓	✓	✓	✓	✓	✓	✓								g

Phone numbers for the agencies listed above are located in the Area Specific Information 13-Mar-25

✓ Compulsory contact

\* CER is a compulsory contact only for emergencies and near-misses involving CER regulated sites and inter-provincial pipelines.

\*\* Refer to the British Columbia Petroleum Release Reporting Requirements chart included in the ERP.

\_ Technical Safety BC only requires reporting of rail related accidents, incidents and spills. No other transportation related emergencies need to be reported.

EMCR to notify the BCER for all incident types including fire/explosion incidents, pressure vessel incidents, spills and releases, or electrical incidents occurring at facilities approved by the BCER.

EMCR to notify the Ministry of Environment and Climate Change Strategy for any incident which affects the water, air, or land environment, or any white or green space in the province.

EMCR to notify Environment & Climate Change Canada (ECCC) of all oil and gas incidents in time, but immediately as required for incidents involving regulated substances at E2 registered facilities, incidents involving PCBs or any spills on First Nations lands, in National Parks, into river or lake systems containing fish, or onto railway right-of-way.

EMCR to notify Ministry of Forests, Northern Health Authority, affected municipalities and all other level of government and industry; depending on the ECC code level in their SOPs.

- Contact the local fire department if there is potential for secondary fires resulting from the ignition of spilled liquids or escaping gases.
  - Contact the Northern Health Authority if the incident affects public health, e.g., contaminated drinking water.
  - Contact the Ministry of Transportation and Transit (MOTT) and the RCMP if the emergency intersects with a 1, 2 or 3 digit Provincial or Secondary highway (e.g., Hwy 2, Hwy 47, Hwy 837). MOTT and RCMP have the authority to shut down highways.
  - Contact Public Services and Procurement Canada (PSPC) and the RCMP if the emergency intersects with the Alaska Highway (97) north of mile 83.5 all the way to the Yukon border. PSPC and RCMP have the authority to shut down this portion of the Alaska highway.
  - Contact the Canadian Transport Emergency Centre (CANUTEC) when a highway is shut down, there is an injury or fatality, there is lost, stolen or unlawfully interfered with dangerous goods (except Class 9), the incident involves infectious substances, there is an accidental release from a cylinder that has suffered a catastrophic failure, where the shipping documents display CANUTEC's telephone number, where a railway vehicle, ship, aircraft aerodrome or an air cargo facility is involved, when a facility is closed, evacuation/shelter-in-place procedures take place as a result of the transportation of dangerous goods, containment has been damaged and integrity compromised, or the centre/stub sill of a tank car is broken or there is a crack in the metal ≥ 15cm(6"). CANUTEC can also provide guidance on handling procedures for toxic material releases.
  - Emergency Response Assistance Canada will only respond to transportation incidents and only incidents that involve the following UN numbers: 1075 (Propane, Butane, etc.) and 1010 (Butadiene); and those products have tank storage capacity of 450 litres or greater.
  - Indian Oil & Gas (IOGC), the First Nation and the provincial authority must be notified immediately in the event of any health or environment-threatening emergency or off-lease spills on First Nation reserve lands. On-lease spills greater than 1m<sup>3</sup> must be reported to IOGC immediately.
- In the event of a fatality, request that the RCMP contact the Medical Examiner. The RCMP must be notified in the case of lost, stolen or misplaced explosives, radioactive materials or infectious substances.
  - Notify Ministry of Emergency Management and Climate Readiness (EMCR) for all spill and non-spill incidents to receive a Dangerous Goods Incident Report (DGIR) number. EMCR will notify the BCER, Ministry of Environment & Climate Change Strategy, and will provide a representative to coordinate the provincial response.
  - Contact the BCER for any spills or release of hazardous substances that are not provincially regulated (such as radioactive materials), pipeline incidents such as spills during construction phase, exposed pipe caused by flooding, pipeline over pressure, failure (without release) of any pressure control or ESD device during operations, drilling kicks when any of the following occur: pit gain of 3m<sup>3</sup> or greater, casing pressure 85% of MA, 50% out of hole when kicked, well taking fluid (LC), associated spill or general situation deterioration such as leaks, equipment failure or unable to circulate etc., major damage to oil and gas roads or road structures and security related issues which are relatively minor; such information may be required for tracking and monitoring purposes only. The BCER must also be notified of needed emergency oil and gas road closures. The BCER may request a NOTAM order upon request from operator.
  - Local authorities include regional district disaster services, national park authorities and the local police.
  - Contact the Canada Energy Regulator (via the Transportation Safety Board of Canada) for all emergencies and near misses involving CER regulated sites and inter-provincial pipelines. The CER regulates all inter-provincial pipelines and other facilities and sites located in Frontier lands (Northern Canada).
  - Ensure any workplace conditions that present an immediate hazard to other workers are addressed, ensure first aid and medical treatment for the worker, and then notify WorkSafeBC of the incident. The requirement to immediately report a serious injury or fatality is separate from the requirement to report injuries for claims purposes. Failure to immediately notify WorkSafeBC will be considered a breach of section 172 of the Workers Compensation Act. The employer must immediately report the following incidents, injury or not: Any incident that kills, causes risk of death, or seriously diving incident or decompression sickness, a major leak or release of a dangerous substance, a major structural failure or collapse of a structure, equipment, construction support system or excavation, or any serious mishap. Must also report incidents that requires the employee to seek medical attention or cause time-loss from work.
  - Ministry of Environment and Climate Change Strategy was formerly known as Ministry of Water, Land and Air Protection.
  - Technical Safety BC is to be notified immediately in cases of Boilers, Pressure Vessels, Piping and Fittings, Electrical & Gas incidents resulting in a moderate, major and fatal injury or moderate, major or severe property damage. All other incidents must be reported within 24 hours (or as soon as practical). Rail accidents where a person sustains a serious injury or is killed as a result of being on board or getting on or off the rolling stock, or coming into contact with any part of the rolling stock or its contents, or the rolling stock is involved in a grade crossing collision or a derailment, sustains damage that affects its safe operations, or causes or sustains a fire or explosion, or causes damage to the railway, that poses a threat to the safety of any person, property or the environment, or any dangerous good is released.

## BCER Incident Reporting Process

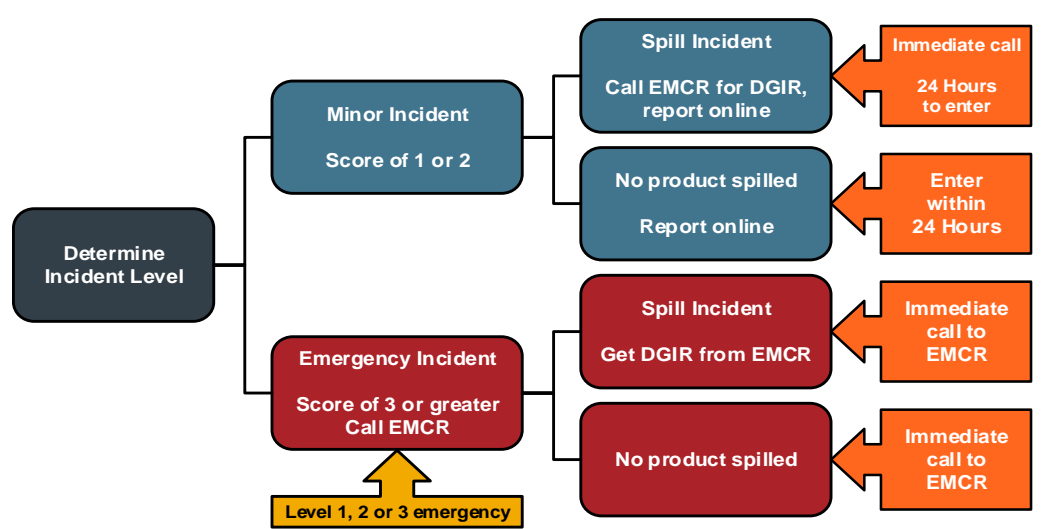

British Columbia Notification Matrix



This page is intentionally left blank

---

	Before the Incident	During the Incident	After the Incident
<b>*BCER</b>	<p>The Emergency Response and Safety Department is the lead department responsible for emergency management within the BCER. The Department oversees the administration of the EMCR. This includes:</p> <ul style="list-style-type: none"> <li><input type="checkbox"/> Reviewing industry emergency management programs and plans</li> <li><input type="checkbox"/> Participating in permit holder emergency response exercises</li> <li><input type="checkbox"/> Providing 24 hour Emergency Officer services</li> <li><input type="checkbox"/> Leading emergency and incident follow-up and investigation</li> <li><input type="checkbox"/> Administering incident and complaint response services</li> </ul> <ul style="list-style-type: none"> <li><input type="checkbox"/> The BCER uses a combination of reviews, assessments, and field inspections.</li> <li><input type="checkbox"/> To ensure permit holders maintain compliance with the requirements detailed in the Emergency Management Regulation and the Oil and Gas Activities Act. The audit and inspection program objectives are to ensure permit holders have adequate processes and procedures in place.</li> <li><input type="checkbox"/> Participate in selected licensee ERP exercises.</li> <li><input type="checkbox"/> Maintain a 24 hour telephone contact where petroleum industry incidents can be reported.</li> </ul>	<p>During emergencies the BC Energy Regulator (BCER) acts as a liaison between industry operators and the provincial emergency management structure to provide situation updates related to threatened oil and gas assets.</p> <ul style="list-style-type: none"> <li><input type="checkbox"/> Oversee operator's response to an incident.</li> <li><input type="checkbox"/> Notified by EMCR of incidents within BCER's jurisdiction (on lease).</li> <li><input type="checkbox"/> Establish communication with operator.</li> <li><input type="checkbox"/> Confirm incident level with operator.</li> <li><input type="checkbox"/> Confirm downgrade of incident level.</li> <li><input type="checkbox"/> Issue road closure order upon request from operator.</li> <li><input type="checkbox"/> Request NOTAM order upon request from the operator.</li> <li><input type="checkbox"/> May send a BCER representative to operator's On-Site Command Post and / or Evacuation Centre.</li> <li><input type="checkbox"/> May establish a government EOC at the BCER office.</li> <li><input type="checkbox"/> Confirm ignition decision with operator if time permits.</li> <li><input type="checkbox"/> Confirm media releases to be sent out by operator.</li> </ul>	<ul style="list-style-type: none"> <li><input type="checkbox"/> Close EOC if established.</li> <li><input type="checkbox"/> Participate in event debriefings.</li> <li><input type="checkbox"/> Receive and review Post-Incident reports.</li> <li><input type="checkbox"/> May audit licensee records.</li> </ul>
<b>*EMCR</b>	<ul style="list-style-type: none"> <li><input type="checkbox"/> Assist the BCER with planning initiatives regarding petroleum industry emergency response as requested by the BCER.</li> <li><input type="checkbox"/> EMCR Northeast Region receives Industry Facility Emergency Response Plans.</li> <li><input type="checkbox"/> Participate in selected licensee ERP exercises when requested as time permits.</li> <li><input type="checkbox"/> Maintain a 24 "800" telephone contact where petroleum industry spill incidents can be reported.</li> <li><input type="checkbox"/> Maintain 24 hour emergency contact numbers for local governments and provincial emergency responders.</li> </ul>	<ul style="list-style-type: none"> <li><input type="checkbox"/> ECC Victoria will notify the BCER on call Emergency Response Officer and initiate British Columbia's notification of government agencies including MOF, MOE, MOT, Health Unit, WorkSafe BC, affected municipalities and all other level of government and industry, depending on the level of "coding" (notification code 1,2,3 is determined by the Lead Agency MOE or BCER), depending on the code level Standard Operating Procedures (SOPs) in ECC will determine who is notified.</li> <li><input type="checkbox"/> Provide representatives to help coordinate provincial response as required.</li> </ul>	<ul style="list-style-type: none"> <li><input type="checkbox"/> As requested by BCER</li> </ul>
<b>Local Authority / Regional Districts</b>	<ul style="list-style-type: none"> <li><input type="checkbox"/> Set up and maintain an emergency management organization which can include an executive committee, emergency program management committee, emergency program coordinator or emergency social services director.</li> <li><input type="checkbox"/> Develop and maintain a Hazard, Risk and Vulnerability Analysis (HRVA) to identify potential emergencies and disasters in its jurisdictional area.</li> <li><input type="checkbox"/> Educate community residents and business owners about the need for personal emergency preparedness.</li> <li><input type="checkbox"/> Prepare for emergencies and disasters through mitigation, preparedness, response and recovery planning.</li> <li><input type="checkbox"/> Conduct training and exercises for all emergency response staff.</li> <li><input type="checkbox"/> Establish procedures for implementing, reviewing and revising response and recovery plans.</li> <li><input type="checkbox"/> Complete periodic reviews and updating of the local emergency plan.</li> <li><input type="checkbox"/> Respond to emergencies when required.</li> <li><input type="checkbox"/> Establish procedures for notifying persons threatened by emergencies or impending disasters.</li> <li><input type="checkbox"/> Identify procedures for obtaining emergency resources.</li> <li><input type="checkbox"/> Establish priorities for restoring essential services.</li> <li><input type="checkbox"/> Work with volunteer groups to plan for the provision of food, clothing and shelter to victims.</li> <li><input type="checkbox"/> Participate in industrial operators' preparatory training and exercises where possible.</li> <li><input type="checkbox"/> Maintain 24 hour emergency contact numbers.</li> </ul>	<ul style="list-style-type: none"> <li><input type="checkbox"/> Provides the local government response for rural and crown areas.</li> <li><input type="checkbox"/> Assesses the situation.</li> <li><input type="checkbox"/> Provides support to the first responders, including resources.</li> <li><input type="checkbox"/> Provides public information, including media briefings.</li> <li><input type="checkbox"/> Coordinates the provision of food, clothing, shelter and transportation.</li> <li><input type="checkbox"/> Liaises with volunteer groups.</li> <li><input type="checkbox"/> Provides situation reports to the PREOC.</li> <li><input type="checkbox"/> Tracks finances.</li> <li><input type="checkbox"/> Coordinates recovery of essential services.</li> <li><input type="checkbox"/> Coordinates community recovery efforts.</li> <li><input type="checkbox"/> During emergencies and disasters the local authority's primary link to the provincial emergency management structure is the PREOC.</li> <li><input type="checkbox"/> When a local authority EOC is activated, police and fire first responder agencies provide situational awareness to the local authority and submit requests for support to the local authority EOC.</li> <li><input type="checkbox"/> Establish contact with the industrial operator in order to: <ul style="list-style-type: none"> <li><input type="checkbox"/> Obtain additional hazard information.</li> <li><input type="checkbox"/> Determine where roadblocks should be or are established.</li> <li><input type="checkbox"/> Determine the direction of approach to the incident.</li> <li><input type="checkbox"/> Determine if there are any injuries.</li> <li><input type="checkbox"/> Find out what response and public protection actions have been taken.</li> <li><input type="checkbox"/> Identify the location of the On-site Command Post (OSCP) and any Emergency Operations Centres (EOCs).</li> </ul> </li> <li><input type="checkbox"/> Activate the MEP, when required.</li> <li><input type="checkbox"/> Manage the Local Authority's emergency response.</li> <li><input type="checkbox"/> Activate the emergency public warning system to alert people to life threatening hazards, as required.</li> <li><input type="checkbox"/> Activate the Municipal EOC (MEOC), as required.</li> <li><input type="checkbox"/> May dispatch a representative to the Government EOC (GEOC), when it is established, to coordinate the response, if requested.</li> <li><input type="checkbox"/> If necessary, declare a local State of Emergency.</li> <li><input type="checkbox"/> When possible, work with all other responders to establish a single Regional EOC (REOC).</li> <li><input type="checkbox"/> Inform EMCR and the public when the emergency is over.</li> </ul>	<ul style="list-style-type: none"> <li><input type="checkbox"/> Complete a "lessons learned" process based on the scope of involvement and provide any feedback to the industrial operator.</li> <li><input type="checkbox"/> Participate in multi-agency debriefings.</li> </ul>
<b>*BC Emergency Services</b>	<p>The first level of emergency response is provided by fire and/or police services and may involve the activation of the Emergency Operations Centre (EOC). Other first responders, such as the RCMP and British Columbia Ambulance Service, have a provincial mandate but with a local presence through detachments or stations. These agencies are usually accessed through 911 and have internal dispatch arrangements.</p> <ul style="list-style-type: none"> <li><input type="checkbox"/> First responders work at the site level of an event and include police, fire and ambulance. Activities of first responders include medical response, firefighting and managing crowds or evacuation zones.</li> <li><input type="checkbox"/> When a local authority EOC is activated, police and fire first responder agencies provide situational awareness to the local authority and submit requests for support to the local authority EOC.</li> <li><input type="checkbox"/> First response services provided by a fire department are determined by the local authority responsible, and may include hazardous material incident response, road rescue, and medical rescue.</li> <li><input type="checkbox"/> The BC Ambulance Service (BCAS) operates under the authority of the Emergency and Health Services Commission (EHSC) and is tasked with the provision of pre-hospital emergency care and transport of patients across the province.</li> <li><input type="checkbox"/> BCAS staff actively participates in emergency planning, mock emergency exercises and other joint training initiatives to ensure emergency preparedness and response resources are identified and deployed quickly and effectively when they are needed most.</li> <li><input type="checkbox"/> Participate in industrial operators' exercises where possible.</li> <li><input type="checkbox"/> Maintain 24 hour emergency contact numbers.</li> </ul>	<p><b>RCMP</b></p> <ul style="list-style-type: none"> <li><input type="checkbox"/> Maintain law and order and assist the operator with security.</li> <li><input type="checkbox"/> Assist with mobilization of additional resources as directed by EMCR.</li> <li><input type="checkbox"/> Assist with traffic control, evacuation, and residence security.</li> <li><input type="checkbox"/> Assist with setting up and maintaining roadblocks or closures of 1, 2 and 3 digit Provincial or Secondary highways.</li> <li><input type="checkbox"/> Establish and maintain communications with industrial operator.</li> <li><input type="checkbox"/> Dispatch a representative to the off-site Regional Emergency Operations Centre, when established, to coordinate the response.</li> <li><input type="checkbox"/> Coordinate with the industrial operator both the establishment and the administration of reception centres for evacuees.</li> <li><input type="checkbox"/> Maintain a 24 hour emergency contact number where resources can be accessed for a response related to Emergency Response Plans.</li> </ul> <p><b>Fire</b></p> <ul style="list-style-type: none"> <li><input type="checkbox"/> Respond to and assess emergency incident to the scope of their abilities.</li> <li><input type="checkbox"/> Establish a unified OSCP / ICP (On-site Command Post / Incident Command Post).</li> <li><input type="checkbox"/> Communicate to MEOC and provide site reps as required.</li> <li><input type="checkbox"/> Assist with fire protection where trained personnel are available.</li> <li><input type="checkbox"/> Provide emergency medical assistance, as required.</li> <li><input type="checkbox"/> Coordinate news releases with the licensee, if required.</li> </ul> <p><b>EMS</b></p> <ul style="list-style-type: none"> <li><input type="checkbox"/> Respond to and assess emergency incident to the scope of their abilities.</li> <li><input type="checkbox"/> The BC Ambulance Service provides and coordinates ambulance services within British Columbia, including triage, treatment, transportation and care of casualties.</li> <li><input type="checkbox"/> The BC Ambulance Service provides situational awareness and coordinates resources through the PREOCs and PECC.</li> <li><input type="checkbox"/> Provide medical aid and transportation of ill or injured workers to a medical facility during high risk operations as required under the <i>WCB Act</i> and <i>WSBC Regulations</i>.</li> <li><input type="checkbox"/> Provide emergency medical assistance, as required.</li> </ul>	<ul style="list-style-type: none"> <li><input type="checkbox"/> Complete a "lessons learned" process based on the scope of involvement and provide any feedback to the industrial operator.</li> <li><input type="checkbox"/> Participate in multi-agency debriefings.</li> </ul>

# Lead Agency Roles



## Northern Health Authority

### Before the Incident

- Northern Health is the regional health authority responsible for providing health services to 300,000 people over an area of 600,000 square kilometers in the province of British Columbia. Services include:
- Acute (hospital) Care
  - Public Health (Protection, Preventive and Population Health services)
  - Mental Health and Addictions
  - Home and Community Care
- In the event of a major emergency/disaster, Northern Health will provide health care services within its capacity, and will activate its emergency response management plan(s).
- Participate with industry, local authority and other partners in the development of their Emergency Response Plans as it relates to health authority roles and responsibilities.
- Participate in stakeholder training and exercises associated with activation of an Emergency Response Plan, in which Northern Health or HEMBC have a role and responsibility.

## Ministry of Justice

- The Police and Community Safety Branch of the Ministry of Justice will work with EMCR to:
- Prepare, promulgate and implement orders relating to law enforcement and internal security.
  - Provide through the jurisdictional police force:
    - Advice to local authorities respecting the maintenance of law and order
    - Reinforcement of local police services
    - Security control of emergency areas; and
    - Traffic and crowd control
  - The Ministry of Justice provides legal services to the government. Policy direction and legislative changes are made in consultation with the Ministry of Justice. During emergencies or disasters the Ministry of Justice may be called on to assist with risk management and provide expertise. This could include providing advice to provincial ministries and government corporations on legal matters relating to the preparation and promulgation of emergency orders, regulations, declarations and contractual arrangements.

### During the Incident

- Activate internal emergency response management plans related to ongoing provision of its services
- Provide acute care and emergency services at existing Northern Health hospitals/health centres.
- Work with BC Emergency Health Services (Ambulance) and the BC Patient Transfer Network to transport patients to the appropriate levels of care.
- Apply and enforce the Public Health Act, and associated regulations.
- Provide advice/information to the stakeholders on the existing or potential public health effects of an incident (including drinking water safety, air quality, environmental contaminants, communicable disease prevention, re-occupancy of evacuated areas, etc.).
- Provide advice/information on the best methods for monitoring health effects from an incident.
- Assist in development of (joint) messaging for public information on emergency incidents.
- Provide guidance to stakeholders and local authorities on public health considerations in operating reception and evacuation centres, and group lodging facilities.

- Jurisdictional police forces to task search and rescue services for missing persons on land and in inland waters.
- Before, during and after an emergency the Ministry of Justice could be called upon to provide expertise, technical advice and/or policy direction regarding police and correctional services.
- The Minister of Justice has overall responsibility for emergency management in the province. In the event of a disaster, the Minister may:
  - Declare a provincial state of emergency
  - Make a formal written request for federal assistance or aid from the Government of Canada
  - Direct the establishment of M-DEC
  - Inform his/her colleagues of the situation, and
  - Be available for media interviews

### After the Incident

Type of Agency	Agency Name	Provided Specific Roles	Willing to consider a single REOC	Evacuation outside of the EPZ	Location of EOC	Suggested Reception Centres
<b>Government</b>	Emergency Management Climate Readiness	X	Yes, where possible	N/A	EMCR Office 3235 Weswood Drive, Prince George, BC	N/A
<b>Health Authority</b>	Northern Health Authority	X	N/A	Yes, where possible.	N/A	N/A
<b>Local Authority</b>	Peace River Regional District	X	Yes, where possible	Require assistance from licensee with coordinating evacuation outside of EPZ.	PRRD Office 1981 Akaska Avenue Dawson Creek, BC	N/A
<b>Transportation Authority</b>	Ministry of Transportation & Transit	X	Yes, where possible	Yes, where possible.	300-10003 110 Ave. Fort St. John	N/A

This Page is Intentionally Left Blank

## Roles & Responsibilities During an Incident

---

BCER's incident responsibilities begin as soon as awareness of a potential incident is realized. This notification may be:

- By EMCR or other crown agencies of incidents within BCER's jurisdiction.
- Permit holder of incidents within BCER's jurisdiction.

BCER duty staff and emergency management will, as the severity of an incident may determine:

- Establish communication with the permit holder.
- Confirm incident level with permit holder.
- Oversee the permit holder's response to an incident.
- Issue road closure orders, upon request from the permit holder
- Request NOTAM orders from NAV Canada, upon request from the permit holder
- May send a BCER representative to one or more of the permit holder's command posts.
- May establish a government emergency operations centre (EOC) at the BCER office.

Additionally, BCER emergency management operations may do any of the following as necessary:

- Confirm ignition decision with operator if time permits.
- Confirm / coordinate media releases issued by permit holder.
- Confirm downgrade of incident level.
- Issue orders to preserve an incident site for investigation.

### **BCER's 24-hour emergency phone lines:**

Industry: 1-800-663-3456 (via Emergency Management & Climate Readiness)

Members of the Public (Toll Free): 1-877-500-2237 (BCER)



## **BC Ministry of Emergency Management and Climate Readiness (EMCR)**

### **Emergency Response Roles & Responsibilities**

#### **Before An Emergency**

- Assist the BCER with planning initiatives regarding upstream petroleum industry emergency response as requested by the BCER
- EMCR Northeast Region receives Industry Facility Emergency Response Plans.
- Participate in selected licensee ERP exercises when requested as time permits.
- Maintain a 24 hour 800 telephone contact where petroleum industry spill incidents can be reported.
- Maintain 24 hour emergency contact numbers for local governments and provincial emergency responders.

#### **During an Emergency**

- ECC Victoria will notify the BCER on call Emergency Response Officer and initiate British Columbia's notification of government agencies including MOF, MOE, MOT, Health Unit, WorkSafe BC, affected municipalities and all other level of government and industry, depending on the level of "coding" (notification Code: 1,2,3 is determined by the Lead Agency MOE or BCER); depending on the code level Standard Operating Procedures (SOP's) in ECC will determine who is notified).
- Provide representatives to help coordinate provincial response as required.

#### **After an Emergency**

- As requested by BCER.



# Emergency Response Roles & Responsibilities

---

## **Health Emergency Management BC, North (HEMBC)**

HEMBC is a program under the Provincial Health Services Authority (PHSA). HEMBC provides the expertise, education, tools, and support specifically for the BC Health Sector to effectively mitigate, prepare for, respond to, and recover from the impacts of emergency events; ensuring the continuity of health services. There is a HEMBC team in each BC health authority. HEMBC-North deals specifically with Northern Health.

### **Roles and responsibilities:**

- Maintain a 24-hour emergency/on call contact number for notification and activation of the health system in Northern BC ( appendix I)
- Notify/activate the appropriate Northern Health programs (i.e. Public Health, Acute Care, etc.) based on the nature of the incident/emergency event.

## **Northern Health (NH)**

Northern Health is the regional health authority responsible for providing health services to 300,000 people over an area of 600,000 square kilometers in the province of British Columbia. Services include:

- Acute (hospital) Care
- Public Health (Protection, Preventive and Population Health services)
- Mental Health and Addictions
- Home and Community Care

In the event of a major emergency/disaster, Northern Health will provide health care services within its capacity, and will activate its emergency response management plan(s).

### **NH Roles & responsibilities - PREPAREDNESS (PRE-EVENT):**

- Participate with industry, local authority and other partners in the development of their Emergency Response Plans as it relates to health authority roles and responsibilities:
- Participate in stakeholder training and exercises associated with activation of an Emergency Response Plan, in which Northern Health or HEMBC have a role and responsibility (as resources allow);

**NH Roles & responsibilities - RESPONSE:**

- Activate internal health emergency management plans related to ongoing provision of services (listed above);
- Provide acute care and emergency services at existing Northern Health hospitals/health centres;
- Work with BC Emergency Health Services (Ambulance) and the BC Patient Transfer Network to transport patients to the appropriate levels of care;
- Apply and enforce the Public Health Act, and associated regulations;
- Provide advice/information to the stakeholders on the existing or potential public health effects of an incident (including drinking water safety, air quality, environmental contaminants, communicable disease prevention, re-occupancy of evacuated areas, etc.);
- Provide advice/information on the best methods for monitoring health effects from an incident.
- Assist in development of (joint) messaging for public information on emergency incidents;
- Provide guidance to stakeholders and local authorities on public health considerations in operating reception and evacuation centres, and group lodging facilities

**NOTE:** British Columbia Emergency Health Services (BCEHS - Ambulance) remains independent of Northern Health. If an ambulance is required please contact BCEHS via 911 (or the local contact number, if 911 is not available in your area).

## Appendix I

### NH/HEMBC- Contact information

1. **For Emergency events that require immediate connection with Northern Health, please call :**
  - HEMBC on call number ( 24/7) **855-554-3622** (or 855-55-HEMBC)
    - HEMBC will notify/activate the appropriate Northern Health programs (i.e. Public Health, Acute Care, etc.) based on the nature of the event/emergency. Please include this number in industry ERPS, for the use of permit holders in contacting Northern Health on an emergency basis.
    - **Please do NOT** include this number on Public Awareness Pamphlets for individual projects; the EMBC/Oil and Gas Commission's emergency number(s) is more appropriate, and the HEMBC 24/7 number is on record with those agencies.
  
2. **For non-urgent requests related to Emergency Response Plans, or emergency exercise planning/information, contact HEMBC North Director Mary Charters, at:**
  - 250-617-5288
  - [HEMBC@northernhealth.ca](mailto:HEMBC@northernhealth.ca)
  
3. **For Environmental assessment inquires and general government consultation questions pertaining to health please email the NH Office of Health and Resource Development at:**
  - [resource.development@northernhealth.ca](mailto:resource.development@northernhealth.ca)





## PEACE RIVER REGIONAL DISTRICT

---

1981 Alaska Avenue, Box 810, Dawson Creek, BC, V1G 4H8

Tel: 250-784-3200, Fax: 250-784-3201. [www.prrd.bc.ca](http://www.prrd.bc.ca)

### **Local Authority (Regional District)**

Peace River Regional District (PRRD) has a formal Emergency Management Plan, which outlines the measures and sources of assistance that can be obtained to support emergency response efforts, within their jurisdictional boundaries. Upon request from the BC Energy Regulator (BCER), the Regional District may address emergency response capabilities, expectations and preparedness. If required or requested the Regional District may activate their emergency plan in order to achieve any of the following:

- Work with the BCER's Emergency Operations Centre (EOC) if established
  - With remote support as a cooperating agency through the BCER Liaison Officer and/or,
  - In the BCER operations section as an assisting agency
- Provide support and assistance to ensure notification of endangered area residents
  - Mass Alerting
  - Notifications
- Provide support to coordinate the delivery of Emergency Support Services (ESS) to evacuated or effected residents
- If necessary, declaration of a State of Local Emergency to enact legislative powers including but not limited to:
  - Issuance of Evacuation Alerts, Orders and Rescinds (persons, livestock, and animals);
  - Acquire or use any land or personal property considered necessary to prevent, respond or alleviate the effects of an event (following BCEMS Model); and
  - Control or Prohibit Travel in the region for safety
- Assist with public information service (joint, BCER, Industry and local government)
- Assist with the provision of building re-entry procedures jointly with utility providers, industry, Northern Health, and Technical Safety BC.

*Revised July 17, 2023*

**diverse. vast. abundant.**



## Ministry of Transportation & Transit – Roles & Responsibilities

### Before the Incident

- Maintain a 24 hour emergency contact number where resources can be accessed for a response related to Emergency Response Plans.
- In the event of an emergency, the Highway Department's Operations, Maintenance and Reconstruction team plays an important role to ensure the public is safe and transportation routes are available for accessing emergency services.
- Ministry of Transportation and Transit oversees provincial highways identified as emergency response routes - a network of pre-identified routes that can best move emergency services and supplies to where they are needed in response to a major disaster.
- Disaster Response Routes (DRRs) are a critical part of the overall emergency transportation system.
- Responsible for the construction, maintenance and operation of public roads.

### During the Incident

Before, during and after an emergency the Ministry of Transportation & Transit (MoTT) could be called upon to provide expertise, technical advice and/or policy direction regarding:

- Highway construction and maintenance
- Safety and protection of provincial road and bridge infrastructure
- Transportation planning and policy

MoTT can:

- Authorize the closure of provincial transportation routes, including highways and inland ferries, where the safety of the public is at risk.
- Assist in public notification through the DriveBC website, as well as posting advisories on overhead message boards along designated routes.
- Coordinate and arrange for transportation, engineering and construction resources.
- Rebuild and restore provincial highways that are impacted by an emergency.

### After the Incident

- Work with appropriate local and federal entities to facilitate the restoration of roadways and utilities.



	Before the Incident	During the Incident	After the Incident
*MECCS	<ul style="list-style-type: none"> <li>Provide regulatory oversight and monitor the situation to ensure that the Responsible Party (RP) is taking appropriate actions.</li> </ul> <p><b>Can liaise with Ministry of Forests to provide:</b></p> <ul style="list-style-type: none"> <li>Species and ecosystem protection policy.</li> <li>Water protection and sustainability policy.</li> <li>Conservation and resource management enforcement.</li> </ul>	<p>Before, during and after an emergency the Ministry could be called upon to provide expertise, technical advice and/or policy direction regarding:</p> <ul style="list-style-type: none"> <li>Environmental emergency response (including hazardous materials)</li> <li>Air, land and water quality standards</li> <li>Pollution prevention and waste management</li> <li>Water and air monitoring and reporting</li> <li>Environmental assessment</li> <li>Environmental monitoring</li> <li>Parks, wilderness and protected areas.</li> </ul> <ul style="list-style-type: none"> <li>Provide regulatory oversight and monitor the situation to ensure that the Responsible Party (RP) is taking appropriate actions.</li> <li>May provide a representative to the Incident Command Centre, the Off-Site Command EOC and the BCER Emergency Operations Centre (EOC) and / or the Provincial Emergency Operations Centre (PREOC) on a 24-hour basis.</li> <li>In a larger scale incident, based on risk, additional ministry resources such as IMTs (Incident Management Teams) may be deployed to establish unified command and monitor, augment, or take over the response if the RP fails to take appropriate action as deemed necessary by the EERO or Provincial Incident Commander.</li> <li>May assist the RP to ensure that other required agencies and affected stakeholders are contacted.</li> <li>May provide assistance with hazardous waste management.</li> <li>May conduct sampling for monitoring and enforcement purposes.</li> </ul>	
Ministry of Forests	<ul style="list-style-type: none"> <li>Five key agencies are housed within the Ministry of Forests: Wildfire Management Branch, Dam Safety, Flood Safety, GeoBC and the River Forecast Centre.</li> <li>Develop, deliver and promote innovative and effective wildfire management practices to clients.</li> <li>Maintain a 24 hour emergency contact number where resources can be accessed for a response related to Emergency Response Plans.</li> <li>The Ministry of Forests is identified to provide personnel, equipment, supplies, telecommunications equipment, aviation support and weather information to assist in emergency response operations.</li> <li>The Ministry of Forests is the designated key agency for wildfires.</li> </ul>	<p>Before, during and after an emergency the Ministry of Forests could be called upon to provide expertise, technical advice and/or policy direction regarding:</p> <ul style="list-style-type: none"> <li>Forest stewardship policy</li> <li>Land use planning</li> <li>Water use planning and authorizations</li> <li>Drought management</li> <li>Dam and dike safety and regulation</li> <li>Flood plain management</li> <li>GeoBC and information management</li> <li>Pests, disease, invasive plants and species</li> <li>Wildfire management</li> </ul>	<ul style="list-style-type: none"> <li>Participate in event debriefings.</li> <li>Complete a "lessons-learned" process based on the scope of their involvement and the outcome.</li> </ul>
* MOTT	<ul style="list-style-type: none"> <li>Maintain a 24 hour emergency contact number where resources can be accessed for a response related to Emergency Response Plans.</li> <li>In the event of an emergency, the Highway Department's Operations, Maintenance and Re-construction team plays an important role to ensure the public is safe and transportation routes are available for accessing emergency services.</li> <li>Ministry of Transportation and Transit oversees provincial highways identified as emergency response routes - a network of pre-identified routes that can best move emergency services and supplies to where they are needed in response to a major disaster.</li> <li>Disaster Response Routes (DRRs) are a critical part of the overall emergency transportation system.</li> <li>Responsible for the construction, maintenance and operation of public roads.</li> </ul>	<p>Before, during and after an emergency the Ministry of Transportation and Transit (MOTT) could be called upon to provide expertise, technical advice and/or policy direction regarding:</p> <ul style="list-style-type: none"> <li>Highway construction and maintenance</li> <li>Safety and protection of provincial road and bridge infrastructure</li> <li>Transportation planning and policy</li> </ul> <p>MOTT can:</p> <ul style="list-style-type: none"> <li>Authorize the closure of provincial transportation routes, including highways and inland ferries, where the safety of the public is at risk.</li> <li>Assist in public notification through the DriveBC website, as well as posting advisories on overhead message boards along designated routes.</li> <li>Coordinate and arrange for transportation, engineering and construction resources.</li> <li>Rebuild and restore provincial highways that are impacted by an emergency.</li> </ul>	<ul style="list-style-type: none"> <li>Work with appropriate local and federal entities to facilitate the restoration of roadways and utilities.</li> </ul>
*PSPC	<p>The Roles &amp; Responsibilities listed below for Public Services and Procurement Canada (PSPC) are only in relation to the Alaska Highway (97) in British Columbia, north of mile 83.5 (km 133) to the border of British Columbia and Yukon Territories at km 968.</p> <p>In conjunction with the BC Ministry of Transportation &amp; Transit (MOTT) and the provincial maintenance contractor, PSPC may:</p> <ul style="list-style-type: none"> <li>Maintain a 24 hour emergency contact number where resources can be accessed for a response related to Emergency Response Plans.</li> <li>Hold responsibility for the acquisition of contracts for the maintenance and operation of the Alaska Highway.</li> <li>Oversee Alaska Highway response routes - a network of pre-identified routes that can best move emergency services and supplies to where they are needed in response to a major disaster.</li> </ul>	<p>In conjunction with the BC Ministry of Transportation &amp; Transit (MOTT), PSPC, and the provincial maintenance contractor may be called upon to:</p> <ul style="list-style-type: none"> <li>Provide expertise, technical advice and/or policy direction regarding: <ul style="list-style-type: none"> <li>Highway construction and maintenance</li> <li>Safety and protection of provincial road and bridge infrastructure</li> <li>Transportation planning and policy</li> </ul> </li> <li>Play an important role to ensure the public is safe and transportation routes are available for accessing emergency services.</li> <li>Assist in the coordination of roadblock locations along the highway.</li> <li>Authorize closure of the Alaska Highway where the safety of the public is at risk.</li> <li>Assist in public notification of an emergency through the MOTT's DriveBC website, as well as posting advisories on overhead message boards along designated routes.</li> <li>Coordinate and arrange for transportation, engineering and construction resources.</li> <li>Handle inter-departmental communication as needed during energy resources industry emergencies.</li> <li>Maintain ability to process calls for new emergencies.</li> <li>Provide information on the impacts to transportation routes.</li> <li>Provide response support if dangerous goods are released.</li> </ul>	<ul style="list-style-type: none"> <li>Work with appropriate local and federal entities to facilitate the restoration and re-opening of the Alaska Highway.</li> <li>Complete a "lessons learned" process based on the scope of involvement and provide any feedback to the industrial operator.</li> <li>Provide a summary of transportation impacts during the post incident review process.</li> <li>Participate in multi-agency debriefings.</li> </ul>
Technical Safety BC	<ul style="list-style-type: none"> <li>Technical Safety BC (formerly BC Safety Authority) is an independent, self-funded organization mandated to oversee the safe installation and operation of technical systems and equipment across the province.</li> <li>In addition to issuing permits, licenses and certificates, we work with industry to reduce safety risks through assessment, education and outreach, enforcement, and research.</li> </ul>	<ul style="list-style-type: none"> <li>Technical Safety BC implements a business continuity plan in the event of a natural disaster. This plan ensures that Technical Safety BC resumes safety services as soon as possible.</li> <li>Though Technical Safety BC is not a first responder, they will provide technical support including inspection services to the recovery team relating to the technical equipment and systems covered by the Safety Standards Act (e.g., gas, electrical, elevating devices, boiler and pressure vessel technologies) after first ensuring the safety of its employees.</li> <li>Starting in the planning phase and through collaboration with other agencies, Technical Safety BC can provide most value to the public and best support the other agencies.</li> </ul>	<ul style="list-style-type: none"> <li>Technical Safety BC tracks and investigates incidents and hazards that are reported to inform awareness and prevention initiatives</li> <li>Technical Safety BC does not investigate all reported incidents and may not follow-up with a notification unless there is an intention to investigate.</li> <li>Technical Safety BC will contact duty holders within 24 hours of the next regular business day following the report of an incident if more information is required or an investigation is planned to occur.</li> </ul>

# Supporting Agency Roles



# Supporting Agency Roles



	Before the Incident	During the Incident	After the Incident
<b>Ministry of Health</b>	<ul style="list-style-type: none"> <li><input type="checkbox"/> Provide public health measures, including epidemic control and immunization programs.</li> <li><input type="checkbox"/> Provide and coordinate ambulance services and triage, treatment, transportation and care of casualties.</li> <li><input type="checkbox"/> Provide the continuity of care for patients evacuated from hospitals or other health institutions and for medically dependent patients from other care facilities.</li> <li><input type="checkbox"/> Provide standard medical units consisting of emergency hospitals, advanced treatment centres, casualty collection units and blood donor packs.</li> <li><input type="checkbox"/> Monitor potable water supplies.</li> <li><input type="checkbox"/> Inspect and regulate food quality with the assistance of the Minister of Agriculture.</li> <li><input type="checkbox"/> Provide critical incident stress debriefing and counselling services.</li> <li><input type="checkbox"/> Provide support services for physically challenged or medically disabled people affected by an emergency.</li> <li><input type="checkbox"/> Maintain a 24 hour emergency contact number where resources can be accessed for a response related to Emergency Response Plans.</li> <li><input type="checkbox"/> Provide input on public health issues related to a petroleum incident.</li> </ul>	<p>Before, during and after an emergency the Ministry of Health could be called upon to provide expertise, technical advice and/or policy direction regarding:</p> <ul style="list-style-type: none"> <li><input type="checkbox"/> Health service delivery</li> <li><input type="checkbox"/> Public health planning and response</li> <li><input type="checkbox"/> Community and home support services</li> <li><input type="checkbox"/> Mental health</li> <li><input type="checkbox"/> Communicable disease prevention</li> </ul> <ul style="list-style-type: none"> <li><input type="checkbox"/> During an emergency the Ministry of Health will provide the continuity of care both for patients evacuated from hospitals or other health institutions and for medically dependent patients from other care facilities; The Ministry will also provide emergency psychosocial services.</li> <li><input type="checkbox"/> Ensure appropriate Health entities have been notified of the incident.</li> <li><input type="checkbox"/> Ensure appropriate Executive and Public Health personnel have been notified of the incident.</li> <li><input type="checkbox"/> Carry out evacuation of medically dependent and vulnerable populations, as needed.</li> <li><input type="checkbox"/> Transport incident casualties as required.</li> <li><input type="checkbox"/> Triage and provide medical care to incident casualties as required.</li> <li><input type="checkbox"/> Decontaminate incident casualties that present to health care facilities, as needed.</li> <li><input type="checkbox"/> Relay health hazard information to the public.</li> <li><input type="checkbox"/> Monitor water and air quality, as it relates to public health.</li> <li><input type="checkbox"/> Coordinate the public health response to the incident.</li> <li><input type="checkbox"/> Address the psychosocial aspects of the aftermath of an event.</li> <li><input type="checkbox"/> Arrange with Health Canada and the Public Health Agency of Canada for federal support, if needed.</li> </ul>	<ul style="list-style-type: none"> <li><input type="checkbox"/> Participate in event debriefings.</li> <li><input type="checkbox"/> Complete a "lessons-learned" process based on the scope of their involvement and the outcome.</li> <li><input type="checkbox"/> Continue with public health and environmental health monitoring as required.</li> <li><input type="checkbox"/> Continue to address the psychosocial aspects of recovery.</li> </ul>
<b>WorkSafeBC</b>	<p>WorkSafeBC is the BC Health and Safety Regulator. In addition to providing a no-fault insurance system and providing when work-related injuries or diseases occur compensation and support to workers in their recovery, rehabilitation, and safe return to work; WorkSafeBC assists workers in creating and maintaining healthy and safe work workplaces, with Proactive roles which include:</p> <ul style="list-style-type: none"> <li><input type="checkbox"/> Providing health and safety information to employers, workers, and the public</li> <li><input type="checkbox"/> Establishing standards and guidelines for occupational health and safety</li> <li><input type="checkbox"/> Educating employers, supervisors, and workers on prevention of work-related injury and illness.</li> <li><input type="checkbox"/> Conducting work site inspections to help employers comply with health and safety regulations.</li> <li><input type="checkbox"/> Collaborating with provincial and federal agencies and ministries on matters of occupational health and safety</li> <li><input type="checkbox"/> Providing access to prevention resources for workers and employers</li> </ul>	<p>As required by the Workers Compensation Act (WCA Sec 68) <b>Employers must immediately report the following types of incidents</b> to WorkSafeBC at 1-888-621-7233 (whether there is an injury or not):</p> <ul style="list-style-type: none"> <li><input type="checkbox"/> Any incident that kills or seriously injures a worker</li> <li><input type="checkbox"/> A major leak or release of a dangerous substance</li> <li><input type="checkbox"/> A major structural failure or collapse of a structure, equipment, construction support system, or excavation</li> <li><input type="checkbox"/> A fire or explosion that had a potential for causing serious injury to a worker</li> <li><input type="checkbox"/> Any blasting accident that results in injury, or unusual event involving explosives (required by regulation)</li> <li><input type="checkbox"/> A diving incident that causes death, injury, or decompression sickness requiring treatment (required by regulation)</li> </ul> <p>This requirement is in addition to the requirement of reporting workplace injuries or disease for claims purposes.</p>	<p>Prompt investigation of incidents must be conducted to identify causation and prevent recurrence. The WCA (sec 69) requires preliminary investigations to be conducted within 48 hours and full investigations completed within 30 days of the following types of incidents:</p> <ul style="list-style-type: none"> <li><input type="checkbox"/> is required to be reported under section 68 (specified above),</li> <li><input type="checkbox"/> resulted in injury to a worker requiring medical treatment,</li> <li><input type="checkbox"/> did not involve injury to a worker, or involved only minor injury not requiring medical treatment, but had a potential for causing serious injury to a worker, or</li> <li><input type="checkbox"/> was an incident required by regulation to be investigated.</li> </ul> <p>The investigation process must be carried out by persons knowledgeable about the type of work involved and, if they are reasonably available, with the participation of the employer or a representative of the employer and a worker representative. Full investigations must be submitted to WorkSafeBC.</p>
<b>Ministry of Agriculture and Food</b>	<p>Emergency management support roles for all hazards (upon request of Local Authority, First Nation, EMCR, or other requesting agency):</p> <ul style="list-style-type: none"> <li><input type="checkbox"/> Provide advice to farmers, aqua-culturalists and fishers on the protection of crops, livestock and provincially managed fish and marine plant stocks.</li> <li><input type="checkbox"/> Coordinate the emergency evacuation and care of poultry and livestock.</li> <li><input type="checkbox"/> Inspect and regulate food quality.</li> <li><input type="checkbox"/> Identify food and potable water supplies.</li> <li><input type="checkbox"/> Assist the Minister of Health in the inspection and regulation of food safety.</li> </ul>	<p>The designated lead provincial ministry for planning and response before, during and after an emergency for:</p> <ul style="list-style-type: none"> <li><input type="checkbox"/> Diseases and epidemics as specified below: <ul style="list-style-type: none"> <li><input type="checkbox"/> Animal diseases</li> <li><input type="checkbox"/> Plant diseases</li> <li><input type="checkbox"/> Pest infestations</li> </ul> </li> </ul>	
<b>HEMBC North</b>	<p>Health Emergency Management BC (HEMBC) is a program under the Provincial Health Services Authority (PHSA). HEMBC provides the expertise, education, tools, and support specifically for the BC Health Sector to effectively mitigate, prepare for, respond to, and recover from the impacts of emergency events; ensuring the continuity of health services. There is a HEMBC team in each BC health authority. HEMBC-North deals specifically with Northern Health.</p> <ul style="list-style-type: none"> <li><input type="checkbox"/> Maintain a 24-hour emergency/on call contact number for notification and activation of the health system in Northern BC.</li> </ul>	<ul style="list-style-type: none"> <li><input type="checkbox"/> For emergency events that require immediate connection with Northern Health, please call HEMBC on call (24/7) - <b>855-554-3622</b>. HEMBC will notify / activate the appropriate Northern Health programs (ie. Public Health, Acute Care etc.) based on the nature of the event / emergency. Please include this number in industry ERPs for the use of permit holders in contacting Northern Health on an emergency basis.</li> <li><input type="checkbox"/> Notify/activate the appropriate Northern Health programs (i.e. Public Health, Acute Care, etc.) based on the nature of the incident/emergency event.</li> </ul>	

## Before the Incident

## During the Incident

## After the Incident

\*ECCC

Environment & Climate Change Canada's Environmental Emergencies Program (EEP) protects Canadians and their environment from the effects of environmental emergencies through provision of science-based expert advice and regulations. The key Acts and Regulations that govern ECCC's role in environmental emergencies that allow it to deliver its mandate are:

- Canadian Environmental Protection Act, 1999
- Fisheries Act—Pollution Prevention Provisions;
- Migratory Birds Convention Act, 1994;
- Statutory Notification Requirements—EC's Environmental Notification System.
- Environmental Emergencies Regulations.

\*DFO

The Canadian Coast Guard is the lead federal agency for ensuring appropriate response to all ship-source and unknown mystery spills in Canadian waters and waters under international agreements.

- Establishes appropriate and nationally consistent level of preparedness and response services in Canadian waters.
- Design and develop related regulations, policies, strategies and tools.
- Review, assess and monitor activities associated with fish habitat to ensure their compliance with the Fisheries Act and Species at Risk Act.
- Conduct environmental assessments under the Canadian Environmental Assessment Act.
- Design, develop and implement communication and education strategies.

NAV  
Canada

NAV Canada is a private company who coordinates the safe and efficient movement of aircraft in Canadian domestic airspace and international airspace assigned to Canadian control.

**Flight Information Centre (FIC) – FIC Services**  
Each Flight Information Centre is responsible for providing its particular service area with the following services, which pilots rely upon for safe flight planning and operations:

- Emergency
- Aviation Weather Briefing
- Flight Planning
- En-route Flight Information Services
- Remote Aerodrome Advisory Services (RAAS)

Health  
Canada

- Sets national standards to keep the environment healthy, keep water and air pollution low and Canadians safe.
- Maintains a nationwide network of radiation monitoring stations and can act if levels spike.
- Under Chemicals Management Plan, assess health risks from chemicals used in manufacturing and agriculture and require users to prove they actually need the chemicals to make their products
- Sets strict rules on how chemicals are used in order to limit human exposure.
- Preparedness exercises are designed to test how well the plans and procedures work during simulated emergency situations. Such exercises help the government identify strengths as well as any problems or inadequacies in preparedness plans and procedures so that these can be addressed before, not after, an actual emergency.

Public Health  
Agency of Canada

The Centre for Emergency Preparedness and Response (CEPR) is responsible for:

- Developing and maintaining national emergency response plans for the Public Health Agency of Canada and Health Canada.
- Assessing public health risks during emergencies.
- Contribution to keeping Canada's health and emergency policies in line by collaborating with other federal and international health and security agencies.
- The health authority in the Government of Canada on bioterrorism, emergency health services and emergency response.
- Strengthen intergovernmental collaboration on public health and facilitate national approaches to public health policy and planning.
- Manages emergency preparedness and emergency response plans and keeps them up to date.
- Develops and runs exercises to train emergency workers.
- Develops and delivers training courses that teach health workers how to respond to emergencies.

During an environmental emergency, *The National Environmental Emergencies Centre (NEEC)* is the focal point for ECCC.

### ECCC's services during an environmental emergency:

- Collaborate with federal, provincial, territorial and international environmental protection agencies to enable rapid sharing of information.
- Convene and chair a Science Table of experts and stakeholders to develop consensus based advice to the Lead Agency.
- Identify environmentally sensitive areas and priorities (sensitivity and resource at risk mapping).
- Advise on mitigation and cleanup measures.
- Provide support and guidance in the assessment of oiled shorelines to prioritize their protection and cleanup (Shoreline Cleanup Assessment Technique (SCAT)).
- Advice on the fate and behavior of the spilled product.
- Advice on sampling and laboratory analysis.
- Provide weather forecasting and spill dispersion modelling to identify where these substances are likely to move in the environment.
- Provided expertise on the migratory bird resources and species at risk, including on-site assessment and determination of wildlife impact.
- Can conduct post-emergency assessments.

- Any amount of hydrocarbons entering a waterway frequented by fish or occupied by waterfowl is deemed to be in contravention of the Federal Fisheries Act and must be reported to the Department of Fisheries and Oceans.
- Work together with provincial environment protection agencies and may be initially notified by ECCC.
- May send personnel to the site if there has been or could potentially be an impact to fish or fish habitat.
- Monitors and investigates all reports of marine pollution in Canada in conjunction with other federal departments.
- Maintains communications with the program's partners, including Transport Canada and ECCC, to ensure a consistent coordinated approach to marine pollution incident response.
- Aids in search and rescue operations.

- As requested by the oil and gas company, the Flight Information Centre will issue a NOTAM (Notice to Airmen).
- To close air space beyond an airport (e.g. above a sour gas release), Refer to Transport Canada on back side of this page.

- During a health emergency or disaster, Health Canada and the Public Health Agency of Canada are responsible for supporting emergency health and social services in the provinces and territories.

- In an emergency situation, the Office of Emergency Response Services (OERS) is responsible for supporting emergency health and social services in the provinces, territories or abroad. It manages the National Emergency Stockpile System (NESS), which includes medical, pharmaceutical and related emergency supplies. The Office is responsible for the federal response to emergencies that have health repercussions; this includes the deployment of health emergency response teams (HERT).
- If a public health emergency grows beyond one province and/or territory, the Public Health Agency of Canada usually gets involved.

- ECCC can conduct post-emergency assessments.
- Provide specialized advice in shoreline clean-up assessment techniques (SCAT).
- Provide Advise on mitigation and cleanup measures..

- Work closely with ECCC, The Canadian Coast Guard and other provincial environmental agencies.

- Rescind the NOTAM.

- Work collaboratively with the provinces and territories to test ways in which the Canadian health care system can be improved and ensure its sustainability for the future.

- Work with Health Canada to test ways in which the Canadian health care system can be improved and ensure its sustainability for the future.

# Federal Agency Roles



	Before the Incident	During the Incident	After the Incident
<b>Transport Canada</b>	<ul style="list-style-type: none"> <li><input type="checkbox"/> Maintain a 24 hour emergency telephone service.</li> </ul> <p><b>*CANUTEC</b></p> <ul style="list-style-type: none"> <li><input type="checkbox"/> Regulate the handling, offering for transport and the transport of dangerous goods by all modes in order to ensure public safety.</li> <li><input type="checkbox"/> Federal regulations require that CANUTEC be contacted in the event of an incident or accident involving dangerous goods and infectious substances.</li> <li><input type="checkbox"/> Maintains records of over 3 million Safety Data Sheets (SDS).</li> </ul> <p>Aviation Operations Centre (AVOPS)</p> <ul style="list-style-type: none"> <li><input type="checkbox"/> Federal regulations require that AVOPS be contacted if there is imminent and immediate threat to aviation and public safety.</li> </ul>	<p><b>*CANUTEC</b></p> <ul style="list-style-type: none"> <li><input type="checkbox"/> Assist emergency response personnel in handling dangerous good emergencies including advice on                             <ul style="list-style-type: none"> <li><input type="checkbox"/> Chemical, physical and toxicological properties and incompatibilities of the dangerous goods</li> <li><input type="checkbox"/> Health hazards and first aid</li> <li><input type="checkbox"/> Fire, explosion, spill or leak hazards</li> <li><input type="checkbox"/> Remedial actions for the protection of life, property and the environment</li> <li><input type="checkbox"/> Evacuation distances</li> <li><input type="checkbox"/> Personal protective clothing and decontamination</li> </ul> </li> <li><input type="checkbox"/> CANUTEC staff does not go to the site of an incident, however, should on-site assistance be required, CANUTEC can assist in the activation or industry emergency response plans.</li> <li><input type="checkbox"/> Provide communication links with the appropriate industry, government or medical specialists.</li> </ul> <p>Aviation Operations Centre (AVOPS)</p> <ul style="list-style-type: none"> <li><input type="checkbox"/> To close air space beyond an airport in a defined area (e.g. above a sour gas release), AVOPS can be contacted by the oil and gas company.</li> </ul>	<p><b>*CANUTEC</b></p> <ul style="list-style-type: none"> <li><input type="checkbox"/> Maintain voice communication and written information records for two years for the protection of all parties.</li> </ul> <p>Aviation Operations Centre (AVOPS)</p> <ul style="list-style-type: none"> <li><input type="checkbox"/> Rescind the NOTAM and re-open air space that was closed due to emergency.</li> </ul>
<b>*PSC</b>	<ul style="list-style-type: none"> <li><input type="checkbox"/> Public Safety Canada works with provincial and territorial officials to ensure first responders and emergency management personnel are well-prepared through education, support and exercises.</li> <li><input type="checkbox"/> Responsible for promoting and coordinating the preparation of departmental emergency management plans as well as coordinating the government's response to an emergency through the Government Operations Centre (GOC).</li> </ul>	<ul style="list-style-type: none"> <li><input type="checkbox"/> Public Safety Canada houses the Government Operations Centre at the hub of the national emergency management system. It's an advanced centre for monitoring and coordinating the federal response to an emergency.</li> </ul>	<ul style="list-style-type: none"> <li><input type="checkbox"/> In the event of a large-scale natural disaster where response and recovery costs exceed what individual provinces and territories could reasonably be expected to bear on their own, PS provides financial assistance to the provincial and territorial governments through the Disaster Financial Assistance Arrangements (DFAA). Assistance is paid to the province or territory – not directly to individuals or communities. The provincial or territorial governments design, develop and deliver disaster financial assistance, determining the amounts and types of assistance that will be provided to those who have experienced losses.</li> </ul>

### \*Canada Energy Regulator Roles & Responsibilities

The CER's top priority in any emergency is to make sure that people are safe and secure, and that property and the environment are protected. Any time there is a serious incident, CER inspectors may attend the site to oversee a company's immediate response. The CER will require that all reasonable actions are taken to protect employees, the public and the environment. Further, the CER will verify that the regulated company conducts adequate and appropriate clean-up and remediation of any environmental effects caused by the incident.

As lead regulatory agency, the CER:

- Monitors, observes and assesses the overall effectiveness of the company's emergency response in terms of:
  - Emergency Management
  - Safety
  - Security
  - Environment
  - Integrity of operations and facilities; and
  - Energy Supply.
- Investigates the event, either in cooperation with the Transportation Safety Board of Canada, under the Canada Labour Code, or as per the *Canada Energy Regulator Act* or *Canada Oil & Gas Operations Act* (whichever is applicable)
- Inspects the pipeline or facility
- Examines the integrity of the pipeline or facility
- Requires appropriate repair methods are being used
- Appropriate environmental remediation of contaminated areas is conducted
- Coordinate stakeholder and Aboriginal community feedback regarding environmental clean-up and remediation
- Confirms that a company is following its Emergency Procedures Manual (s), commitments, plans, procedures, and CER regulations and identifies non-compliances
- Initiates enforcement actions as required
- Approves the restart of the pipeline.

If applicable; refer to the CER site section behind the blue Area Specific Information tab for further regulations, definitions and, reporting guidelines for CER related incidents specific to this ERP.

### \*Transportation Safety Board Mandate

The Canadian Transportation Accident Investigation and Safety Board Act provides the legal framework that governs TSB activities. Our mandate is to advance transportation safety in the marine, pipeline, rail and air modes of transportation by:

- conducting independent investigations, including public inquiries when necessary, into selected transportation occurrences in order to make findings as to their causes and contributing factors;
- identifying safety deficiencies, as evidenced by transportation occurrences;
- making recommendations designed to eliminate or reduce any such safety deficiencies; and
- reporting publicly on our investigations and on the findings in relation thereto.

As part of its ongoing investigations, the TSB also reviews developments in transportation safety, and identifies safety risks that they believe the government and the transportation industry should address to reduce injury and loss.

To instill confidence in the public regarding the transportation accident investigation process, it is essential that an investigating agency be independent and free from any conflicts of interest when investigating accidents, identifying safety deficiencies, and making safety recommendations. As such, the TSB is an independent agency, separate from other government agencies and departments, that reports to Parliament through the President of the Queen's Privy Council for Canada. Our independence enables us to be fully objective in making findings as to causes and contributing factors, and in making transportation safety recommendations.

In identifying the causes and contributing factors of a transportation incident, it is not the function of the Board to assign fault or determine civil or criminal liability. However, the Board does not refrain from fully reporting on the causes and contributing factors merely because fault or liability might be inferred from the Board's findings. No finding of the Board should be construed as assigning fault or determining civil or criminal liability. Findings of the Board are not binding on the parties to any legal, disciplinary, or other proceedings.

<http://tsb-bst.gc.ca/eng/qui-about/index.html>

### \*Indigenous Services Canada, Regional Operations and First Nations and Inuit Health Branch

Since the Government of Canada's renewed commitment to a stronger relationship with Indigenous peoples in Canada, measures were initiated to effect a shift in the way the Government delivers services to Indigenous peoples. This included the creation of two new departments, which was announced on December 4, 2017. The two newly created departments, Crown-Indigenous Relations and Northern Affairs Canada (CIRNAC) and Indigenous Services Canada (ISC), are intended to improve the delivery of services while accelerating movement towards self-government and self-determination of Indigenous peoples.

As part of the departmental transition, both the former Regional Operations (RO) part of Indigenous and Northern Affairs Canada (INAC) and all of First Nations and Inuit Health Branch (FNIHB) of Health Canada have been absorbed into the newly created Indigenous Services Canada (ISC). RO and FNIHB work closely and collaborate towards the provision of emergency preparedness and response activities to First Nations communities in Canada.

In regards to First Nations emergency management, the role of RO is to liaise, communicate, cooperate, coordinate and collaborate with First Nations and public, private, and non-government sector partners in support of on reserve emergency management service delivery. ISC-RO supports First Nations in the four pillars of emergency management through service agreements with partners such as provincial emergency management agencies and the Red Cross.

FNIHB carries out the public health preparedness and response activities related to natural and man-made disasters. This includes Communicable Disease Control and Environmental Public Health Services. In addition, FNIHB administers Non-Insured Health Benefits to First Nations clients, which includes extended coverage for medical transportation, pharma-care, medical devices and mental health supports. During an emergency, FNIHB works with First Nations leadership and health service providers to ensure health needs of First Nations communities are met.

Provincial specific FNIHB roles & responsibilities will be found in this section of the ERP, if applicable or as appropriate.

### \*Indian Oil & Gas Canada

IOGC is an organization committed to managing and regulating oil and gas resources on First Nation reserve lands. It is a special operating agency within Indigenous Services Canada.

IOGC is responsible for oil and gas on First Nation reserve lands across Canada, but only a handful of reserves exist north of the 60th parallel. Therefore, practically all of IOGC's work is south of the 60th parallel, with most of that in the Western Canada Sedimentary Basin.

IOGC's general responsibilities are to:

- identify and evaluate oil and gas resource potential on Indian reserve lands;
- encourage companies to explore for, drill and produce these resources through leasing activity;
- ensure equitable production, fair prices and proper collection of royalties on behalf of First Nations; and
- secure compliance with and administer the regulatory framework in a fair manner.

IOGC operates pursuant to the *Indian Oil and Gas Act, 2009*, and its associated *Indian Oil and Gas Regulations, 2019*, as well as other relevant legislation and guidelines (see Acts and Regulations) which came into force and became law on August 1, 2019. Oil and gas activity on First Nation reserve lands depends on agreements involving First Nation band councils, oil and gas companies, and Indian Oil and Gas Canada.

Additional information is available at: <http://www.pgic-iogc.gc.ca/eng/1100110010458/1100110010464>  
Acts and Regulations: <https://www.pgic-iogc.gc.ca/eng/1100110010437/1100110010438>

# Section 6: Forms

## Documentation During and After an Incident

### Form Descriptions

#### Incident Command System (ICS) Forms

- ICS 201 Incident Briefing
- ICS 202 Incident Objectives
- ICS 203 Organization Assignment List
- ICS 204 Assignment List
- ICS 207 Incident Organization Chart
- ICS 208 Safety Message / Plan
- ICS 209 Incident Status Summary
- ICS 211 Check-In / Out List
- ICS 214 Activity Log
- ICS 215 Operational Planning Worksheet
- ICS 215A IAP Safety Analysis
- ICS 221 Demobilization Checkout
- ICS 230 Meeting Schedule
- ICS 231 Meeting Summary
- ICS 233 Incident Open Action Tracker

#### Emergency Forms

- A1 Initial Emergency Report Form
- A2 Odour Complaint Script
- A3 Regulatory First Call Communication
- A4 Incident Action Plan Checklist
- A5 Air Monitoring Log
- A6 Threatening Call / Bomb Threat
- A7 STARS Landing Zone Card
- A8 BCER – Form A
- A9 BCER – Form D

#### Resident Forms

- B1 Reception Centre Registration Log
- B2 Resident Compensation Log
- B3 Resident Contact Log
- B4 Roadblock Log
- B5 Evacuation Notice
- B6 Early Notification / Voluntary Evacuation Phone Message
- B7 Shelter-In-Place Phone Message
- B8 Evacuation Phone Message

#### Media Forms

- C1 Preliminary Media Statement
- C2 Media Contact Log
- C3 Government Agency Contact Log
- C4 Media Centre Site

This page is intentionally left blank

---

## Documentation During and After an Incident

It is imperative that accurate documentation is kept throughout the duration of an incident for record keeping purposes. Records kept may be used for legal, investigation, audits, historical and/or analytical purposes. All documentation must be held for a minimum of 5 years as it may be requested by the regulatory agency at any point during that time.

It is the Documentation Units responsibility to collect documentation (forms, checklists, event logs, etc.) from response team members and maintain a consistent system for organizing the data.

## Form Descriptions

The Incident Command System uses a series of standard forms and supporting documents that convey directions for the accomplishment of the objectives and distributing information. Listed below are the standard ICS form titles and descriptions of each form utilized.

Further ICS forms can be found through the ICS Canada website: <https://icscanada.ca/resources/ics-forms>.

Standard ICS Form Title	ICS Form Description
ICS 201 Incident Briefing	Provides the Incident Command and General Staffs with basic information regarding the incident situation and the resources allocated to the incident. This form also serves as a permanent record of the initial response to the incident.
ICS 202 Incident Objectives	Describes the basic strategy and objectives for use during each operational period.
ICS 203 Organization Assignment List	Provides ICS personnel with information on the units that are currently activated and the names of personnel staffing each position.
ICS 204 Assignment List	Informs Division and Group supervisors of incident assignments.
ICS 207 Incident Organization Chart	A complete picture of the organizational structure for the incident.
ICS 208 Safety Message / Plan	Expands on the Safety Message and Site Safety Plan.
ICS 209 Incident Status Summary	Summarizes incident information for staff members and external parties, and provides information to the Public Information Officer for preparation of media releases.
ICS 211 Check-In/Out List	Used to check in personnel and equipment arriving at or departing from the incident. Check-in / out consists of reporting specific information that is recorded on the form.
ICS 214 Activity Log	Provides a record of unit activities. Unit Logs can provide a basic reference from which to extract information for inclusion in any after-action report.
ICS 215 Operational Planning Worksheet	Documents decisions made concerning resource needs for the next operational period. The Planning Section uses this Worksheet to complete Assignment Lists, and the Logistics Section uses it for ordering resources for the incident. This form may be used as a source document for updating resource confirmation on other ICS forms such as the 209 Incident Status Summary.
ICS 215A Incident Action Plan Safety Analysis	Used to communicate to the Operations and Planning Section Chiefs the potential hazards identified by the Safety Officer. It identifies mitigation measures to address the identified hazards.

## Form Descriptions, continued

Standard ICS Form Title	ICS Form Description
ICS 221 Demobilization Checkout	Ensures that resources checking out of the incident have completed all appropriate incident business, and provides the Planning Section information on resources released from the incident.
ICS 230 Meeting Schedule	To record information about the daily scheduled meeting activities.
ICS 231 Meeting Summary	Provides more detailed information concerning the attendees and notes from a particular meeting.
ICS 233 Incident Open Action Tracker	Used by Command Staff to track time sensitive tasks / actions assigned to incident personnel.

Emergency Form Title	Emergency Form Description
A1 Initial Emergency Report Form	Used by recipient of a phone call from either a member of the public or other company personnel to record detailed information about incident.
A2 Odour Complaint Script	Used to record odour information from a member of the public as well as scripts to follow.
A3 Regulatory First Call Communication	A regulatory required form used to send detailed information to the regulator about an emergency used for assessment, historical, and analytical purposes following an incident.
A4 Incident Action Plan Checklist	A checklist of other forms and information required to accurately create an incident action plan.
A5 Air Monitoring Log	A form used by designated Air Monitor personnel to log information about air quality readings.
A6 Threatening Call / Bomb Threat	Detailed point driven form used to document incoming phone calls pertaining to personnel threats and bomb threats.
A7 Stars Landing Zone Card	An information card utilized if medical evacuation is required via STARS Air Ambulance.
A8 BCER- Form A	Minor Incident Notification Form to be used for incidents that do not meet BCER Level 1, 2 or 3 classification
A9 BCER – Form D	Permit Holder Post Incident Report to be used after a level 1, 2 or 3 emergency.

## Form Descriptions, continued

<b>Resident Form Title</b>	<b>Resident Form Description</b>
B1 Reception Centre Registration Log	Log used by Reception Centre Rep to record information from evacuees being received at the reception centre. Can also be faxed to reception centre in case a representative has not been identified or cannot make it before evacuees start arriving.
B2 Resident Compensation Log	Detailed spreadsheet for expenses incurred by evacuees so that compensation may be properly dealt with.
B3 Resident Contact Log	A log used by various company personnel to record contact made with residents, whether they're sheltered / evacuated and if assistance is required.
B4 Roadblock Log	A log used by designated Roadblock personnel to identify details about vehicles and persons entering or exiting a hazard area.
B5 Evacuation Notice	A document to be left in doors / windows of surface developments that are unable to be contacted as a way to issue evacuation instructions
B6 Early Notification/Voluntary Evacuation Message	A script and document filled out by Telephoner personnel issuing calls to residents for early notification and voluntary evacuation purposes.
B7 Shelter-In-Place Message	A script and document filled out by Telephoner personnel issuing calls to residents with shelter-in-place instructions.
B8 Evacuation Phone Message	A script and document filled out by Telephoner personnel issuing calls to residents with evacuation instructions.

<b>Media Form Title</b>	<b>Media Form Description</b>
C1 Preliminary Media Statement	A generic script used by the Media Spokesperson to issue media statements until which time more detailed information is known and can be issued.
C2 Media Contact Log	A log used to identify what media outlets/persons have contacted the company and their contact information.
C3 Government Agency Contact Log	A log used to identify what government agencies have been notified about the incident.
C4 Media Centre Site	A document to distribute to media outlets/persons about the location for further media enquiries and press releases as well as details to get there.

This page intentionally is left blank



# ICS 201 Incident Briefing Form



Current and Planned Objectives:	
Priorities: (1) Life Safety (2) Incident Stabilization (3) Environment & Property	
<b>1. Ensure Safety of Citizens and Response Personnel:</b>	<b>4. Minimize Economic Impacts:</b>
<input type="checkbox"/> 1a. Identify hazard(s) of released product.	<input type="checkbox"/> 4a. Consider tourism and local economic impacts.
<input type="checkbox"/> 1b. Establish site control (hot zone, warm zone, cold zone, & security).	<input type="checkbox"/> 4b. Protect public and private assets, as resources permit.
<input type="checkbox"/> 1c. Establish an Emergency Response Zone and Initiate Public Safety Actions.	<input type="checkbox"/> 4c. Establish damage claims process.
<input type="checkbox"/> 1d. Consider evacuations if needed.	<b>5. Keep Stakeholders and Public Informed of Response Activities:</b>
<input type="checkbox"/> 1e. Establish aircraft restrictions.	<input type="checkbox"/> 5a. Provide forum to obtain stakeholder input and concerns.
<input type="checkbox"/> 1f. Monitor air in impacted areas	<input type="checkbox"/> 5b. Provide stakeholders with details of response actions.
<input type="checkbox"/> 1g. Develop site safety plan for personnel and ensure safety briefings are conducted.	<input type="checkbox"/> 5c. Identify stakeholder concerns and issues, and address as practical.
<b>2. Control the Source of the Release:</b>	<input type="checkbox"/> 5d. Provide timely safety announcements.
<input type="checkbox"/> 2a. Complete emergency shutdown.	<input type="checkbox"/> 5e. Conduct regular news briefings.
<input type="checkbox"/> 2b. Conduct firefighting.	<input type="checkbox"/> 5f. Conduct public meetings, as appropriate.
<input type="checkbox"/> 2c. Initiate temporary repairs.	
<b>3. Manage a Coordinated Response Effort:</b>	
<input type="checkbox"/> 3a. Complete or confirm notifications.	
<input type="checkbox"/> 3b. Establish a unified command organization and facilities (command post, etc.).	
<input type="checkbox"/> 3c. Ensure mobilization and tracking of resources and account for personnel and equipment.	
<input type="checkbox"/> 3d. Complete documentation.	
Current and Planned Actions, Strategies and Tactics:	
Time:	Actions:
HHMM	
HHMM	
HHMM	
HHMM	
HHMM	
HHMM	
HHMM	
HHMM	
HHMM	

**Current Organizational Structure: (draw in current response structure)\***

*\* This is a condensed Organizational Chart to account for all currently responding personnel during the Initial Response.*

**Incident Commander**

Name \_\_\_\_\_

Number \_\_\_\_\_

**Information Officer**

Name \_\_\_\_\_

Number \_\_\_\_\_

**Liaison Officer**

Name \_\_\_\_\_

Number \_\_\_\_\_

**Safety Officer**

Name \_\_\_\_\_

Number \_\_\_\_\_

**On-Site Group Supervisor**

Name \_\_\_\_\_

Number \_\_\_\_\_

**Public Safety Group Supervisor**

Name \_\_\_\_\_

Number \_\_\_\_\_

**Documentation**

Name \_\_\_\_\_

Number \_\_\_\_\_

**SITE SAFETY**

Name \_\_\_\_\_

Number \_\_\_\_\_

**Air Monitors**

Name \_\_\_\_\_

Number \_\_\_\_\_

**Control**

Name \_\_\_\_\_

Number \_\_\_\_\_

**Roadblocks**

Name \_\_\_\_\_

Number \_\_\_\_\_

**Containment**

Name \_\_\_\_\_

Number \_\_\_\_\_

**Rovers**

Name \_\_\_\_\_

Number \_\_\_\_\_

**Other**

Name \_\_\_\_\_

Number \_\_\_\_\_

**Telephoners**

Name \_\_\_\_\_

Number \_\_\_\_\_

**Other**

Name \_\_\_\_\_

Number \_\_\_\_\_

**Reception Centre Representative**

Name \_\_\_\_\_

Number \_\_\_\_\_

**Other**

Name \_\_\_\_\_

Number \_\_\_\_\_

**Other**

Name \_\_\_\_\_

Number \_\_\_\_\_

Note: Refer to ICS 207 Incident Organization Chart in Section 6: Forms (Blue Tab) for full command structure.



# ICS 201 Incident Briefing Form

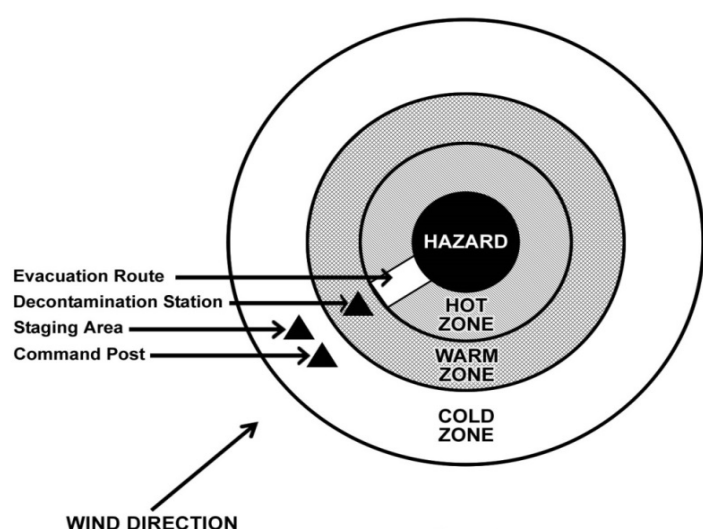

Site Safety and Hazard Control Analysis	
<b>Site Control</b>	
1. Is Site Control set-up? <input type="checkbox"/> Yes <input type="checkbox"/> No	2. Is there an On-Scene Command Post? <input type="checkbox"/> Yes <input type="checkbox"/> No If so, where?
3. Have all personnel been accounted for? <input type="checkbox"/> Yes <input type="checkbox"/> No <input type="checkbox"/> Don't Know	Injuries: _____ Unaccounted: _____ Fatalities: _____ Trapped: _____
4. Are observers involved or rescue attempts planned? Observers: <input type="checkbox"/> Yes <input type="checkbox"/> No Rescuers: <input type="checkbox"/> Yes <input type="checkbox"/> No	5. Are Decon areas setup? <input type="checkbox"/> Yes <input type="checkbox"/> No If so, where?
<b>Hazard Identification, immediate signs of: (if yes, explain in remarks)</b>	
1. Electrical line(s) down or overhead? <input type="checkbox"/> Yes <input type="checkbox"/> No	2. Unidentified liquid or solid products visible? <input type="checkbox"/> Yes <input type="checkbox"/> No
3. Wind direction across incident: <input type="checkbox"/> Towards your position Wind Speed: <input type="checkbox"/> Away from your position	4. Is a safe approach possible? <input type="checkbox"/> Yes <input type="checkbox"/> No
5. Odours or smells? <input type="checkbox"/> Yes <input type="checkbox"/> No	6. Vapours visible? <input type="checkbox"/> Yes <input type="checkbox"/> No
7. Holes, ditches, fast water, cliffs, etc. nearby? <input type="checkbox"/> Yes <input type="checkbox"/> No	8. Fire, sparks, sources of ignition nearby? <input type="checkbox"/> Yes <input type="checkbox"/> No
9. Is local traffic a potential problem? <input type="checkbox"/> Yes <input type="checkbox"/> No	10. Product placards, colour codes visible? <input type="checkbox"/> Yes <input type="checkbox"/> No
11. Other Hazards? <input type="checkbox"/> Yes <input type="checkbox"/> No	12. As you approach the scene from the upwind side, do you note a change in the status of any of the above? <input type="checkbox"/> Yes <input type="checkbox"/> No
13. Remarks:	
<b>Hazard Mitigation: have you determined the necessity for any of the following?</b>	
1. Entry Objectives:	
2. Warning sign(s), barriers, colour codes in place? <input type="checkbox"/> Yes <input type="checkbox"/> No	
3. Hazardous material being monitored? <input type="checkbox"/> Yes <input type="checkbox"/> No 3a. Sampling equipment: 3b. Sampling location(s): 3c. Sampling frequency: 3d. Peak reading: 3e. Personal exposure monitoring:	
4. Protective gear / level: 4b. Respirators 4d. Boots:	4a. Gloves: 4c. Clothing: 4e. Chemical cartridge change frequency:
5. Decon 5a. Instructions: 5b. Decon equipment and materials:	
6. Emergency escape route established? <input type="checkbox"/> Yes <input type="checkbox"/> No Route?	
7. Field responders briefed on hazards? <input type="checkbox"/> Yes <input type="checkbox"/> No	
8. Remarks:	
Protective Zones: record initial control perimeters (see Figure 1)	

 <p style="text-align: center;"><b>Figure 1 Protective Zones</b></p>	<ol style="list-style-type: none"> <li>1. Is there a Hot Zone established?  <input type="checkbox"/> Yes  <input type="checkbox"/> No                      If so, Where?                 </li> <hr/> <li>2. Is there a Warm Zone established?  <input type="checkbox"/> Yes  <input type="checkbox"/> No                      If so, Where?                 </li> <hr/> <li>3. Is there a Cold Zone established?  <input type="checkbox"/> Yes  <input type="checkbox"/> No                      If so, Where?                 </li> <hr/> <li>4. Remarks: (Include any information on evacuation route, etc.)</li> </ol>
<p>5. Include any site sketches or photos of the protective zones (if available):</p> <div style="height: 400px; border: 1px solid black;"></div>	

# ICS 202 Incident Objectives



Incident Name:	
Date / Time Initiated:	
Prepared by:	ICS Position:
<b>General Control Objectives for the Incident:</b>	
1	
2	
3	
4	
5	
<b>Weather Forecast:</b>	
<b>General Safety Message:</b>	
<i>Note: Create and prioritize SMART (Specific, Measureable, Attainable, Realistic, &amp; Time-Sensitive) objectives that address the incident issues and utilize the solutions identified on the Operations Briefing page.</i>	



# ICS 203 Organization Assignment List



<b>Incident Name</b>			<b>Operational Period (Date/Time)</b>	
			From:	To:
<b>Incident Commander(s)</b>			<b>Operations Section</b>	
Agency	IC	Deputy	Chief	
			Deputy	
			Staging Area Manager	
			<b>On-Site Group</b>	
			Supervisor	
<b>Safety Officer</b>			Lead	
Assistant			Lead	
<b>Information Officer</b>			Lead	
Assistant			Lead	
<b>Liaison Officer</b>			Lead	
Assistant				
			<b>Public Safety Group</b>	
			Supervisor	
<b>Agency Representatives</b>			Lead	
Agency	Name		Lead	
			Lead	
			Lead	
			Lead	
			Lead	
			<b>Branch – Division / Group</b>	
			<b>Branch Director</b>	
			<b>Deputy</b>	
<b>Planning Section</b>			Division/Group	Lead
Chief			Division/Group	Lead
Deputy			Division/Group	Lead
Resources Unit			Division/Group	Lead
Situation Unit			Division/Group	Lead
Environmental Unit				
Documentation Unit			<b>Branch – Division / Group</b>	
Demobilization Unit			<b>Branch Director</b>	
Technical Specialists			<b>Deputy</b>	
			Division/Group	Lead
			Division/Group	Lead
<b>Logistics Section</b>			Division/Group	Lead
Chief			Division/Group	Lead
Deputy			Division/Group	Lead
Supply Unit				
Facilities Unit			<b>Finance / Admin Section</b>	
Ground Support Unit			Chief	
Communications Unit			Deputy	
Medical Unit			Time Unit	
Food Unit			Procurement Unit	
			Compensation / Claims Unit	
			Cost Unit	
<b>Prepared By: (Resources Unit)</b>			<b>Date/Time</b>	



# ICS 204 Assignment List



Branch: _____	Division / Group / Staging: _____
Incident Name: _____	Operational Period: From: Date _____ Time _____ To: Date _____ Time _____
Division / Group / Staging Operations Chief _____ Branch Director _____	Division/Group Supervisor _____ Staging Area Manager _____

**Resources Assigned to This Period**

Resource Identifier	Leader	No. of Persons	Contact Cell #, radio freq. Etc.	Reporting Location, Special Equipment and Supplies, Remarks

Work Assignments:

Special Instructions:

  
  
  
  
  
  
  
  
  
  
**Division / Group Communications Summary**

Function	Frequencies	System	Chan.	Function	Frequencies	System	Chan.
Command	Local Repeat			Logistics	Local Repeat		
Div. / Group Tactical				Ground to Air			
Prepared By: (Resource Unit Leader)						Date:	Time:
Signature:							



# ICS 207 Incident Organization Chart

Incident Name: \_\_\_\_\_

Date: \_\_\_\_\_ Time: \_\_\_\_\_

Operational Period: \_\_\_\_\_

- KEY INFORMATION:**
- The Incident Commander is responsible for all Field Response positions until the position is delegated.
  - This organizational chart is a starting point, the structure expands and contracts based on the incident needs.
  - Information can flow anywhere throughout the organizational structure, decisions **must** flow up the chain of command.
  - Company Phone List can be found behind the Response Teams Phone List tab

Indicates a position that is always filled regardless of the size of the incident. 

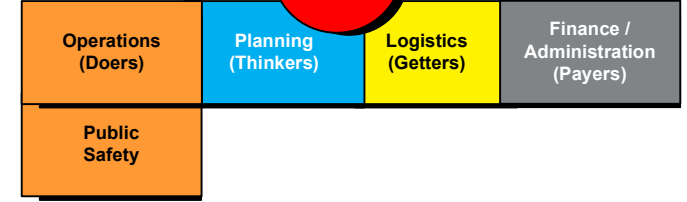
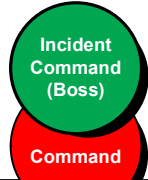
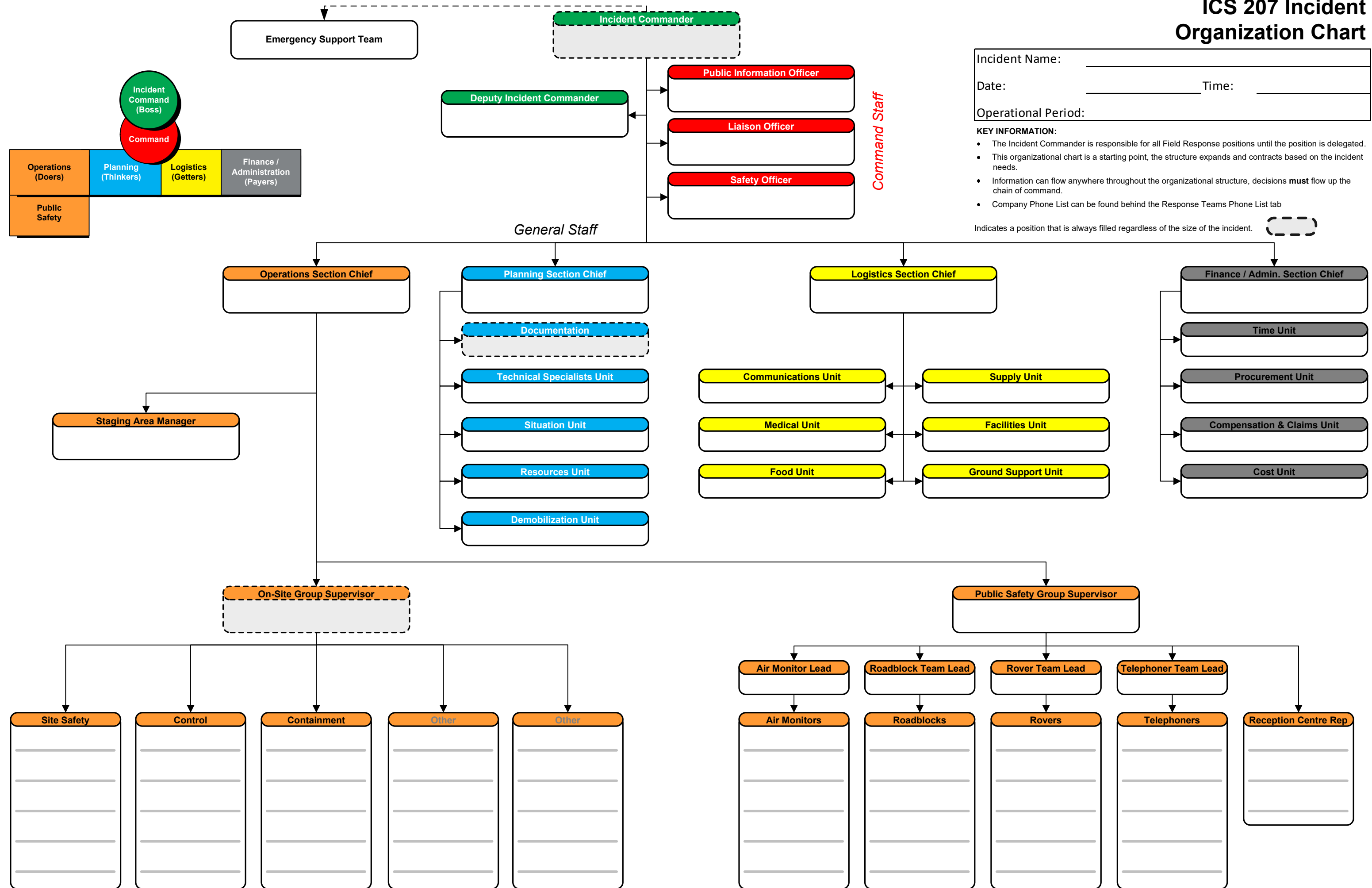

This Page is Intentionally Left Blank

# ICS 208 Safety Message / Plan



Incident Name:	Operational Period: From: Date _____ Time _____ To: Date _____ Time _____	
<b>Safety Message/Expanded Safety Message, Safety Plan, Site Safety Plan:</b>		
<b>Site Safety Plan Required?</b> <input type="checkbox"/> Yes <input type="checkbox"/> No Approved Site Safety Plan(s) Located At:		
Prepared By: (Name and Position)	Date Prepared:	
Signature:	Time Prepared:	



# ICS 209 Incident Status Summary



Incident Name:		Location of Incident:	
Date / Time Initiated:		(LSD / NTS)	
Prepared by:		ICS Position	
<b>Incident Details:</b>			
Gas readings:	H <sub>2</sub> S		LEL
<b>Level of Emergency:</b>			
Incident Severity:		<input type="checkbox"/> Alert / Minor	<input type="checkbox"/> Level 1 <input type="checkbox"/> Level 2 <input type="checkbox"/> Level 3
<b>Affect Medium: (Check all that apply)</b>			
<input type="checkbox"/> Air	<input type="checkbox"/> Water	<input type="checkbox"/> Soil	<input type="checkbox"/> Other – Specify:
<b>Site Type: (Select only 1)</b>			
<input type="checkbox"/> Well (Active)		<input type="checkbox"/> Well (Abandoned/Suspended)	<input type="checkbox"/> Remote Sump
<input type="checkbox"/> Well (Drilling & Completions): Rig Name:			
<input type="checkbox"/> Battery/Plant/Facility		<input type="checkbox"/> Tank Farm/Storage	<input type="checkbox"/> Pipeline
<input type="checkbox"/> Riser (Pipeline)			
<input type="checkbox"/> Road or Road Structure		Name:	Location on Road:
<input type="checkbox"/> Other – Specify:			
<b>Incident Type: (Check all that apply)</b>			
<input type="checkbox"/> Sour Gas Release		<input type="checkbox"/> Sweet Gas Release	<input type="checkbox"/> Liquid Spills
<input type="checkbox"/> Natural Disaster/Weather		<input type="checkbox"/> Fire/Explosion	<input type="checkbox"/> Drilling Kick
<input type="checkbox"/> Worker Injury/Fatality		<input type="checkbox"/> Security (theft, threat, terrorism)	<input type="checkbox"/> Induced Seismicity
<input type="checkbox"/> Well Bore Communication		<input type="checkbox"/> Pipeline Boring	<input type="checkbox"/> Vehicle/Transportation
<input type="checkbox"/> Equipment/Structural Damage		<input type="checkbox"/> Pipeline Break	<input type="checkbox"/> Well Control
<input type="checkbox"/> Other – Specify:			
<b>Activity: (Check all that apply)</b>			
<input type="checkbox"/> Construction (Road, Lease, Pipe)		<input type="checkbox"/> Drilling/Exploration	<input type="checkbox"/> Waste Management
<input type="checkbox"/> Processing		<input type="checkbox"/> Well Fracturing	<input type="checkbox"/> Servicing
<input type="checkbox"/> Repair		<input type="checkbox"/> Flaring (Emergency)	<input type="checkbox"/> Well Testing
<input type="checkbox"/> Pressure Testing		<input type="checkbox"/> Transportation	
<input type="checkbox"/> Other – Specify:			

# ICS 209 Incident Status Summary



Consequence or Impacts: (Check all that apply, if none, leave blank)			
<input type="checkbox"/> Worker Safety (Injuries, Fatalities)		<input type="checkbox"/> Property	
<input type="checkbox"/> Economic (Loss of and/or damage to equipment or infrastructure, loss of production, work stoppage)			
<input type="checkbox"/> Other – Specify:			
Material Information:			
Is spill off lease?		<input type="checkbox"/> Yes - Estimated spill quantity:	<input type="checkbox"/> No
<input type="checkbox"/> Liquid Hydrogen (Crude, Oil, Diesel, Fuel)		<input type="checkbox"/> Toxic Gas Liquid (>1% Different Toxins)	
<input type="checkbox"/> Acid	<input type="checkbox"/> Emulsion (Oil, Gas, Water)	<input type="checkbox"/> Sweet Natural Gas	<input type="checkbox"/> Salt Water
<input type="checkbox"/> Methanol	<input type="checkbox"/> Non-Toxic Liquids	<input type="checkbox"/> Fresh Water	
<input type="checkbox"/> Sour Natural Gas	<input type="checkbox"/> Sour Liquids (<1% H <sub>2</sub> S)	<input type="checkbox"/> Other – Specify:	
<input type="checkbox"/> Non-Toxic Gases (Nitrogen, Carbon Dioxide, Inert Gases)			
Area Information:			
Land Type:		<input type="checkbox"/> Private Land <input type="checkbox"/> Crown Land	Field Name:
Area Type:		<input type="checkbox"/> Forest <input type="checkbox"/> Muskeg <input type="checkbox"/> Farmland <input type="checkbox"/> Residential <input type="checkbox"/> Other	
Access:		<input type="checkbox"/> Helicopter <input type="checkbox"/> ATV <input type="checkbox"/> 4WD <input type="checkbox"/> 2WD <input type="checkbox"/> Unknown	
Name of road the asset is located on:			
KM where the incident occurred:			
Distance to nearest residence/public facility:			
Nearest City/Town/Open Camp:			
Weather Conditions:			
Weather Conditions		<input type="checkbox"/> Clear <input type="checkbox"/> Cloudy <input type="checkbox"/> Other:	
Wind Direction		N    NE    NW    E    SE    S    SW    W	
Wind Strength		<input type="checkbox"/> Calm <input type="checkbox"/> Moderate <input type="checkbox"/> Strong <input type="checkbox"/> Gusty	
Temperature		°C	
Public / Worker Injuries / Medical Emergencies:			
<input type="checkbox"/> First Aid	<input type="checkbox"/> Hospitalization	<input type="checkbox"/> Fatality	<input type="checkbox"/> Other – Specify:
Notification: (Notify all agencies as required)			
<input type="checkbox"/> 911 (Police/RCMP, Fire, EMS)	<input type="checkbox"/> Energy Regulator (BCER, AER*, etc.)	<input type="checkbox"/> Local Authority (MD, County, Town, City)	<input type="checkbox"/> Health Authority
<input type="checkbox"/> Canada Energy Regulator (CER)	<input type="checkbox"/> Occupational Health & Safety (OH&S)	<input type="checkbox"/> Emergency Management Agency	<input type="checkbox"/> Ministry of Transportation
<input type="checkbox"/> Workers' Compensation Board (WCB)	<input type="checkbox"/> Emergency Response Assistance Canada (ERAC)	<input type="checkbox"/> Western Canadian Spill Services (WCSS)	<input type="checkbox"/> CANUTEC
<input type="checkbox"/> Transportation Dangerous Goods (TDG)	<input type="checkbox"/> Other	<input type="checkbox"/> Other	<input type="checkbox"/> Other
<input type="checkbox"/> Other	<input type="checkbox"/> Other	<input type="checkbox"/> Other	<input type="checkbox"/> Other
<small>*Request that the AER notify Alberta Environment &amp; Parks (Forestry/Fish/Wildlife/Lands), Environment &amp; Climate Change Canada (ECCC) and the Department of Fisheries and Oceans as required.</small>			
Refer to the Government Notification Matrix and External Agencies Contact List or Area Specific Information for complete list of agencies requiring contact.			

# ICS 209 Incident Status Summary



Agency Notification			
Agency Name	Contact Name	Contact Number	Notified (Y/N)
Collect all completed C3 Government Agency Contact Logs from responders for full documentation.			
Notes:			
Roadblock Locations:			
Roadblock Number	Name	Location/LSD	
Collect all completed B4 Roadblock Logs from responders for full documentation.			
Notes:			



# ICS 211 Check-In / Out List



Incident Name: \_\_\_\_\_

Date / Time Initiated: \_\_\_\_\_

Prepared by: \_\_\_\_\_ ICS Position: \_\_\_\_\_

Check-in Location  Staging Area  ICS Res. Unit  Other: \_\_\_\_\_

Name of Company	Date of Check-in	Supervisor Name	Total # of Personnel	Incident Assignment	Assigned	Available	Date of Check-out

**Notes:**

\_\_\_\_\_

\_\_\_\_\_

\_\_\_\_\_







# ICS 215 Operational Planning Worksheet



Incident Name:							Operational Period:											
							To: Date _____ Time _____			To: Date _____ Time _____								
Branch	Division, Group, or Other	Work Assignments & Special Instructions	Resources												Overhead Position(s)	Special Equipment & Supplies	Reporting Location	Requested Arrival Time
				Req.	Have	Need												
			Req.	Have	Need													
			Req.	Have	Need													
			Req.	Have	Need													
			Req.	Have	Need													
			Req.	Have	Need													
			Req.	Have	Need													
			Req.	Have	Need													
		Total Resources Required:														Prepared by: Name: Position/Title: Date/Time: Signature:		
		Total Resources - Have on Hand:																
		Total Resources Need to Order:																



# ICS 215a Incident Action Plan Safety Analysis

Incident Name:							Date / Time Initiated:			
Prepared by:							ICS Position:			
Division or Group	Potential Hazards									Controls (e.g., PPE, buddy system, escape routes)
	Type of Hazard	Type of Hazard	Type of Hazard	Type of Hazard	Type of Hazard	Type of Hazard	Type of Hazard	Type of Hazard	Type of Hazard	



# ICS 221 Demobilization Checkout

Incident Name / Number:		Date / Time:		Demob. Number:	
Unit/Personnel Released:					
Transportation Type / Number:					
Actual Release Date / Time:				Manifest Completed? <input type="checkbox"/> Yes <input type="checkbox"/> No	
Destination:		Notify:	<input type="checkbox"/> HQ	<input type="checkbox"/> Agency	<input type="checkbox"/> Region
		Name:			
		Date:			
Unit Leader responsible for collecting performance rating					
<b>Unit / Personnel</b>					
You and your resources have been released subject to Sign-Off from the following: Demobilization Unit Leader – Check the appropriate box					
<b>Logistics Section</b>					
<input type="checkbox"/> Supply Unit					
<input type="checkbox"/> Communications Unit					
<input type="checkbox"/> Facilities Unit					
<input type="checkbox"/> Ground Support Unit Leader					
<b>Planning Section</b>					
<input type="checkbox"/> Demobilization Unit					
<b>Finance/Admin Section</b>					
<input type="checkbox"/> Time Unit					
<b>Other</b>					
<input type="checkbox"/>					
<input type="checkbox"/>					
Remarks:					
Page		of		Prepared By: (Name and Position)	Signature:



# ICS 230 Meeting Schedule



Incident Name:		Operational Period: From: Date _____ Time _____		
<b>Meeting Schedule (Commonly-held meetings are included)</b>				
Date / Time	Meeting Name	Purpose	Attendees	Location
Prepared by: (Situation Unit Leader)			Date / Time:	



# ICS 231 Meeting Summary



Incident Name:	Meeting Date / Time:
Meeting Name:	
Meeting Location:	
Meeting Facilitator:	
Attendees:	
Notes: (with summary of decisions and action items)	
Prepared by:	Date / Time:



# ICS 233 Incident Open Action Tracker



Incident Name:

No.	Item	For	Status	Start Date	Briefed	Target Date	Actual Date
1							
2							
3							
4							
5							
6							
7							
8							
9							
10							
11							
12							
13							
14							
15							
16							
17							
18							
19							
20							

# ICS 233 Incident Open Action Tracker



No.	Item	For	Status	Start Date	Briefed	Target Date	Actual Date
21							
22							
23							
24							
25							
26							
27							
28							
29							
30							
31							
32							
33							
34							
35							
36							
37							
38							
39							
40							

# A1 Initial Emergency Report Form



## First On-Scene Actions

<b>Evacuate</b>	<input type="checkbox"/> Get to a safe area immediately. <input type="checkbox"/> Move upwind if release is downwind of you. <input type="checkbox"/> Move crosswind if a release is upwind from you. <input type="checkbox"/> Move to higher ground if possible.
<b>Alarm</b>	<input type="checkbox"/> Call for help ("Man Down"). <input type="checkbox"/> Sound bell, horn or whistle, or call by radio. <input type="checkbox"/> For medical emergencies, call 911.
<b>Assess</b>	<input type="checkbox"/> Take head count, locate any casualties. Consider all of the hazards. <input type="checkbox"/> Fill out information below to complete assessment.
<b>Protect</b>	<input type="checkbox"/> Put on breathing apparatus before attempting rescue.
<b>Rescue</b>	<input type="checkbox"/> Remove victim to a safe area.
<b>First Aid</b>	<input type="checkbox"/> Follow the standard first aid protocols at worksite. (CPR, etc.)
<b>Medical Aid</b>	<input type="checkbox"/> Arrange transport of casualties to medical aid. <input type="checkbox"/> Provide information to Emergency Medical Services (EMS).

Incident Details <i>To be completed by the person involved or notified</i>	
Report taken by	Date / Time
Name of person calling	Caller Telephone
Incident Location <div style="text-align: center;">(LSD / NTS)</div>	
Event Summary	
<b>Agencies Notified</b> <input type="checkbox"/> Yes    Who? <input type="checkbox"/> No	
<b>Event Status</b> <input type="checkbox"/> Incident contained or controlled <input type="checkbox"/> Intermittent control possible <input type="checkbox"/> Imminent control possible <input type="checkbox"/> Incident is uncontrolled	
<b>Site Type</b> <input type="checkbox"/> Well <input type="checkbox"/> Pipeline <input type="checkbox"/> Tank Farm/Storage <input type="checkbox"/> Battery/Plant/Facility <input type="checkbox"/> Other _____	
<b>Incident Type</b> <input type="checkbox"/> Sour Gas Release <input type="checkbox"/> Sweet Gas Release <input type="checkbox"/> Pipeline Break <input type="checkbox"/> Security (theft, threat, terrorism) <input type="checkbox"/> Loss of Containment <input type="checkbox"/> Fire/Explosion <input type="checkbox"/> Worker Injury/Fatality <input type="checkbox"/> Vehicle/Transportation <input type="checkbox"/> Liquid Spill <input type="checkbox"/> Other _____	

# A1 Initial Emergency Report Form



Impacts			
<b>Public Health and Safety</b>	<input type="checkbox"/> Could be jeopardized <input type="checkbox"/> Is jeopardized		
<b>Public Protection Measures Taken</b>	<input type="checkbox"/> Notification <input type="checkbox"/> Evacuation <input type="checkbox"/> Shelter-in-place <input type="checkbox"/> Roadblocks		
<b>Worker Injuries</b>	<input type="checkbox"/> First Aid <input type="checkbox"/> Hospitalized <input type="checkbox"/> Fatality <input type="checkbox"/> Other _____		
Distance to nearest surface development	_____ km	Distance to nearest urban centre	_____ km
Details			
<b>Release Impact</b>	<input type="checkbox"/> On-Lease <input type="checkbox"/> Off-Lease   Product _____		Amount _____
<b>Gas Readings</b>	H <sub>2</sub> S _____   SO <sub>2</sub> _____   LEL _____   Other _____		
Distance to nearest watercourse	_____ km	Weather Conditions	
Details			
<b>Media Involvement?</b>	<input type="checkbox"/> Yes <input type="checkbox"/> No	<b>Regulator Involvement?</b>	<input type="checkbox"/> Yes <input type="checkbox"/> No
		<b>Public Affairs/Community Relations Issues?</b>	<input type="checkbox"/> Yes <input type="checkbox"/> No
Details			
Notes / Instructions Provided:			

**Distribute this completed report to all Key Response Personnel**

*Note: Ensure the First On-Scene Actions have been completed before proceeding to the Five Step Initial Response Guide.*

# A2 Odour Complaint Script



Date:	Prepared by:
Time: <input type="checkbox"/> a.m. <input type="checkbox"/> p.m.	Duration of call:

To help us understand your immediate needs, we need to know:

**Name:** \_\_\_\_\_

**Contact number:** \_\_\_\_\_

**Description of the concern:** \_\_\_\_\_

\_\_\_\_\_

\_\_\_\_\_

**How many people are you with right now?**

**Adults** \_\_\_\_\_ **Children** \_\_\_\_\_

**Can you provide the location of the incident?**

**Location of the incident (address, legal, landmark, etc.):** \_\_\_\_\_

\_\_\_\_\_

**Where are you right now?**

Home / Work     In a Vehicle     Outside     Other \_\_\_\_\_

**If the resident is at home / work / outside tell them:**

The company will send someone to investigate. To be safe, you and anyone that you may be with need to go inside and stay inside. Close all doors and windows and turn off any appliances that blow out indoor air (i.e. clothes dryer) or suck in outside air (i.e. heating / air conditioning). Do not go outside or attempt to start any vehicles until you are told it is safe to do so.

**If the resident is in a vehicle and cannot shelter-in-place tell them:**

The company will send someone to investigate. To be safe, you and anyone that may be with you need to get inside the vehicle and stay inside. Keep all doors and windows closed and shut off the air conditioning / heat. If you see or hear anything that might indicate where the incident is occurring, travel in the opposite direction of the hazard; otherwise, continue travelling on your current course which will likely take you out of the hazard area.

**Someone will call you back with further instruction so please stay off of the phone so that we can contact you. If you have any urgent questions please call the company at \_\_\_\_\_.**



# A3 First Call Communication



<b>Contact Details</b>	Regulatory Contact		Field Centre			
	Caller				Phone	
	<b>Notification</b>	<b>Date</b>	<b>Time</b>	<b>Release</b>	<b>Start Time</b>	<b>End Time</b> <input type="checkbox"/> <b>Ongoing</b>
	Licensee				Phone	
	<b>Location</b>			<b>Nearest Town</b>		
	Nearest Resident		Distance/Direction			Phone
	<b>Media Involvement?</b>		<input type="checkbox"/> <b>Local</b> <input type="checkbox"/> <b>National</b> <input type="checkbox"/> <b>Regional</b> <input type="checkbox"/> <b>International</b>		Media Contact	
	Operator				Phone	
<b>Public Impact</b>	<b>Public Health and Safety</b>		<input type="checkbox"/> <b>Could be jeopardized</b> <input type="checkbox"/> <b>Is jeopardized</b>		<b>Worker Injuries</b> <input type="checkbox"/> <b>First Aid</b> <input type="checkbox"/> <b>Fatality</b> <input type="checkbox"/> <b>Hospitalization</b>	
	<b>Emergency Assessment Matrix completed with licensee</b>		<input type="checkbox"/> <b>Minor</b> <input type="checkbox"/> <b>Two</b> <input type="checkbox"/> <b>One</b> <input type="checkbox"/> <b>Three</b>		<b>ERP Activated?</b> <input type="checkbox"/> <b>Site Specific</b> <input type="checkbox"/> <b>Corporate</b> <input type="checkbox"/> <b>Field/Area</b>	
	EPZ Size (2 km if unknown)		Numbers and Types of Public in EPZ			EOC/ICP Location
	<b>Public Protection Measures Implemented</b>		<input type="checkbox"/> <b>Notification</b> <input type="checkbox"/> <b>Roadblocks</b> <input type="checkbox"/> <b>Shelter</b> <input type="checkbox"/> <b>Evacuation</b>		Number Evacuated	
<b>Release Type</b>	<b>Release Impact</b>		<input type="checkbox"/> <b>On lease</b> <input type="checkbox"/> <b>Off lease</b>		<b>H<sub>2</sub>S Concentration</b>	
	<input type="checkbox"/> <b>Sensitive Environment</b>		<b>Environment Affected</b> <input type="checkbox"/> <b>Air</b> <input type="checkbox"/> <b>Standing Water</b> <b>Water Body Name</b> <input type="checkbox"/> <b>Land</b> <input type="checkbox"/> <b>Flowing Water</b>			
	Area Affected (m <sup>3</sup> )		<input type="checkbox"/> <b>Property Damage</b> <input type="checkbox"/> <b>Equipment Loss</b> <input type="checkbox"/> <b>Wildlife / Livestock Affected</b>			
	<b>Gas Release</b>		<input type="checkbox"/> <b>Sweet</b> <input type="checkbox"/> <b>Sour</b>		Volume/Rate	
	<b>Liquid Release</b>		<input type="checkbox"/> <b>Oil</b> <input type="checkbox"/> <b>Water</b> <input type="checkbox"/> <b>Effluent</b>		Volume/Rate	
	<input type="checkbox"/> <b>Release Point Determined</b>					
<b>Containment</b>	<b>Third Party / Outside Assistance Required</b>		<input type="checkbox"/> <b>Incident contained or controlled</b> <input type="checkbox"/> <b>Imminent control probable</b> <input type="checkbox"/> <b>Intermittent control possible</b> <input type="checkbox"/> <b>Incident is uncontrolled</b>			
	Company			WCSS Co-op		
<b>Operations Type</b>	Well Licence No.		<b>Type of Incident</b> <input type="checkbox"/> <b>Kick</b> <input type="checkbox"/> <b>Blowout</b> <input type="checkbox"/> <b>Loss of Circulation</b>			
	<b>Well Status</b>		<input type="checkbox"/> <b>Drilling</b> <input type="checkbox"/> <b>Servicing</b> <input type="checkbox"/> <b>Producing</b> <input type="checkbox"/> <b>Injection</b> <input type="checkbox"/> <b>Suspended</b> <input type="checkbox"/> <b>Standing</b> <input type="checkbox"/> <b>Sweet</b> <input type="checkbox"/> <b>Sour</b> <input type="checkbox"/> <b>Critical</b>			
	Pipeline License No.		Line No.		<input type="checkbox"/> <b>Hit</b> <input type="checkbox"/> <b>Leak</b> <input type="checkbox"/> <b>Rupture</b>	
	Production Facility License No.		<input type="checkbox"/> <b>Gas</b> <input type="checkbox"/> <b>Gas Plant</b> <input type="checkbox"/> <b>Compressor</b> <input type="checkbox"/> <b>Oil</b> <input type="checkbox"/> <b>Battery</b> <input type="checkbox"/> <b>Other</b>		AENV Approval No.	

# A3 First Call Communication



<b>Air Monitoring</b>	<input type="checkbox"/> License Air Monitoring Occurring <input type="checkbox"/> Mobile <input type="checkbox"/> Handheld			Estimated Time of Arrival		
	Initial Readings / Location		<input type="checkbox"/> PPB <input type="checkbox"/> On Site <input type="checkbox"/> PPM <input type="checkbox"/> Off Site	Distance		
	Contractor Name		Phone	AMU Phone		
	Wind	Direction	Speed	Meteorological Conditions	AER AMU ETA	
<b>Communications</b>	Communications completed by Licensee and /or Regulatory Agency					
	<input type="checkbox"/> RCMP/Police	<input type="checkbox"/> Energy Regulator	<input type="checkbox"/> Emergency Management Agency	<input type="checkbox"/> TDG	<input type="checkbox"/> OH&S	<input type="checkbox"/> WCB
	<input type="checkbox"/> Ambulance	<input type="checkbox"/> Local Authority	<input type="checkbox"/> Ministry of Transportation	<input type="checkbox"/> CANUTEC	<input type="checkbox"/> DFO	<input type="checkbox"/> WCSS
	<input type="checkbox"/> Fire	<input type="checkbox"/> Health Authority	<input type="checkbox"/> Environment & Climate Change Canada (ECCC)	<input type="checkbox"/> ERAC	<input type="checkbox"/> Other	<input type="checkbox"/> Other
<input type="checkbox"/> CER	<input type="checkbox"/> First Nations	<input type="checkbox"/> Indian Oil & Gas	<input type="checkbox"/> Other	<input type="checkbox"/> Other	<input type="checkbox"/> Other	
Contact Names & Phone Numbers						
Incident Cause <input type="checkbox"/> Natural <input type="checkbox"/> Human-Induced unintentional <input type="checkbox"/> Human-Induced Intentional						
<b>Other Information</b>	<input type="checkbox"/> First Nations Band	Band / Settlement Name / Contact			Phone	
	<input type="checkbox"/> Metis Settlement					
	Complaints	<input type="checkbox"/> Local <input type="checkbox"/> Large area				
	Private Land Title holder				Phone	
Additional Information						

# A4 Incident Action Plan Checklist



IAP Checklist Items:	Comments:
<input type="checkbox"/> ICS 202 – Incident Objectives	
<input type="checkbox"/> ICS 207 – Incident Organizational Chart	
<input type="checkbox"/> ICS 209 – Incident Status Summary	
<input type="checkbox"/> ICS 215 – Operational Planning Worksheet	
<input type="checkbox"/> ICS 215A – IAP Safety Analysis	
<input type="checkbox"/> ICS 230 – Meeting Schedule	
<input type="checkbox"/> ICS 233 – Incident Open Action Tracker	
<input type="checkbox"/> Map: _____	
<input type="checkbox"/> Map: _____	
<input type="checkbox"/> Other: _____	
<input type="checkbox"/> Other: _____	
<input type="checkbox"/> Other: _____	
<b>Notes:</b>	



# A5 Air Monitoring Log



Date: \_\_\_\_\_ Responder Name: \_\_\_\_\_

Page \_\_\_\_\_ of \_\_\_\_\_ Responder Position: \_\_\_\_\_

Time	Location of Samples	H <sub>2</sub> S (ppm)	LEL (%)	O <sub>2</sub> (%)	SO <sub>2</sub> (ppm)	Other	Temp (°C)	Wind Conditions *		Comments
								From	Speed (km/hr)	

\*Estimate meteorological conditions where accurate readings are not available.



# A6 Threatening Call / Bomb Threat



Date:	Time Call Received:	Time Call Reported:		
Person Receiving Call:		What/Whom Call Directed To:		
Caller's Sex: <input type="checkbox"/> Male <input type="checkbox"/> Female <input type="checkbox"/> Unknown		Approximate Age:		
Accent: <input type="checkbox"/> Yes <input type="checkbox"/> No Type:		Familiar voice: <input type="checkbox"/> Yes <input type="checkbox"/> No Who:		
Threat (Exact Wording):				
<b>Tips:</b> <ul style="list-style-type: none"> <li>Listen carefully and remain calm.</li> <li>Do not interrupt caller.</li> <li>Attempt to keep caller talking.</li> <li>Attempt to ask questions below.</li> <li>Obtain as much information as you can while call is in progress.</li> <li><b>Signal someone to call your supervisor; give him / her this information.</b></li> <li><b>Do not hang up or disconnect your phone</b>, even after the caller hangs up.</li> <li>For telephone tracing, call the local telephone company and local police.</li> </ul>				
<b>If bomb threat, ask the following questions:</b>				
When will the bomb go off? <i>(date and time)</i>				
Where is it located?				
Why did you place it?				
What kind of bomb is it?				
What does it look like?				
What is your name?				
Where are you calling from?				
Was the caller familiar with company facilities, or employees? (e.g.: nicknames, familiarity with staff, etc.) <input type="checkbox"/> Yes <input type="checkbox"/> No				
Did caller appear familiar with building / facility by the description of the bomb location? <input type="checkbox"/> Yes <input type="checkbox"/> No				
<b>Identifying Characteristics of Caller</b>				
<b>Voice</b>	<b>Speech</b>	<b>Language</b>	<b>Manner</b>	<b>Background</b>
<input type="checkbox"/> Loud	<input type="checkbox"/> Fast	<input type="checkbox"/> Excellent	<input type="checkbox"/> Calm	<input type="checkbox"/> Office Machines
<input type="checkbox"/> Soft	<input type="checkbox"/> Slow	<input type="checkbox"/> Good	<input type="checkbox"/> Angry	<input type="checkbox"/> Factory Machines
<input type="checkbox"/> High Pitched	<input type="checkbox"/> Distinct	<input type="checkbox"/> Fair	<input type="checkbox"/> Rational	<input type="checkbox"/> Street Traffic
<input type="checkbox"/> Deep	<input type="checkbox"/> Distorted	<input type="checkbox"/> Poor	<input type="checkbox"/> Irrational	<input type="checkbox"/> Airplanes
<input type="checkbox"/> Raspy	<input type="checkbox"/> Stutter	<input type="checkbox"/> Foul Language	<input type="checkbox"/> Coherent	<input type="checkbox"/> Trains
<input type="checkbox"/> Pleasant	<input type="checkbox"/> Nasal	<input type="checkbox"/> Accent	<input type="checkbox"/> Incoherent	<input type="checkbox"/> Animals
<input type="checkbox"/> Intoxicated	<input type="checkbox"/> Slurred	<input type="checkbox"/> _____	<input type="checkbox"/> Deliberate /	<input type="checkbox"/> Party Atmosphere
<input type="checkbox"/> _____	<input type="checkbox"/> _____	<input type="checkbox"/> _____	<input type="checkbox"/> Serious	<input type="checkbox"/> Music
			<input type="checkbox"/> Emotional	<input type="checkbox"/> Voices
			<input type="checkbox"/> Laughing	<input type="checkbox"/> Quiet
			<input type="checkbox"/> Nervous	<input type="checkbox"/> _____
			<input type="checkbox"/> _____	<input type="checkbox"/> _____
Notify proper authorities as soon as possible. Have employees take a look around their immediate work stations for unusual packages. Evacuate building if necessary.				
Name of the supervisor first notified:				



**STARS**® Site Number \_\_\_\_\_  
 Location \_\_\_\_\_

**Remote Site Landing Zone Reference Card**

**In the event of a SITE EMERGENCY  
 PHONE the STARS Emergency Link Centre®**

**TOLL FREE 1-888-888-4567 OR DIRECT 403-299-0932**

**BE PREPARED WITH THE FOLLOWING INFORMATION**

1. STARS Site Number
2. Location of site (Legal Land Description or GPS)
3. Contact phone number at the site
4. Known hazards on-site
5. If applicable, is there a monitor on-site confirming the presence of H<sub>2</sub>S

**SAFETY GUIDELINES**

- the landing zone should be on level ground, (less than 5% slope) at least 36 x 36 metres (120 x 120 ft) and more, if possible, to include a safety zone
- check for loose debris in landing zone THIS IS OF VITAL IMPORTANCE
- ensure no one approaches the helicopter STARS crew will approach you when safe to do so
- everyone should be at least 30 metres from landing zone during landing and takeoff, due to possibility of injury from loose debris caused by rotor downwash
- movement around aircraft is to be in safe areas only
- if necessary, provide road blocks approximately 500 metres on either side of the landing zone

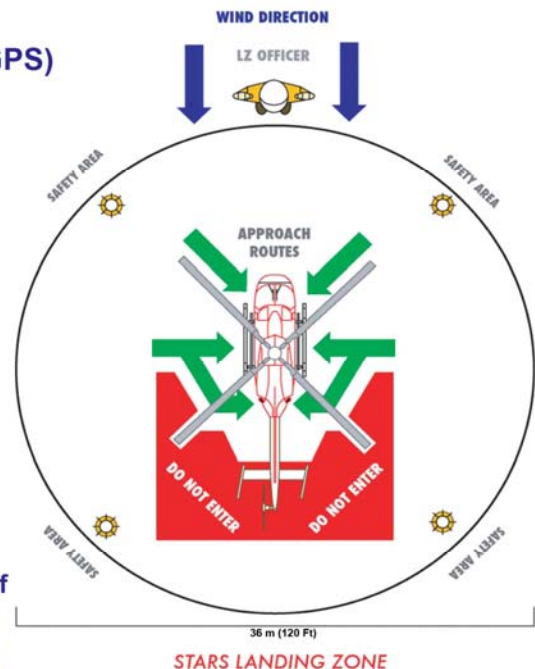

**PRE-LANDING CHECKLIST**

The STARS Emergency Link Centre will require the following information from the site:

TERRAIN	LANDING ZONE MARKINGS	HAZARDS
level or sloping	4 turbo flares	signs
type of surface	4 road flares / strobes	vehicles
dust, loose snow,	4 reflective flares	trees
rocks, bushes,	4 highway cones (days only)	equipment
stumps, etc.	extra strobes/flares/cones on upwind side	wires





**FORM A:  
MINOR INCIDENT  
NOTIFICATION  
FORM**

Physical Address: 6534 Airport Road,  
Fort St. John, B.C. V1J 4M6  
Mailing Address: 6534 100th Ave Fort St.  
John, B.C. V1J 8C5  
Phone: (250) 794-5200  
[emp@bc-er.ca](mailto:emp@bc-er.ca)

*This form is to be used for incidents which do not meet BCER Level 1, 2, or 3 Classification*

*Minor incidents must be reported to the Commission within **24** hours through the Regulator's [Online Minor Incident Reporting System](#), operated through KERMIT.*

MISCELLANEOUS INFORMATION			A
Risk Score:	(attach risk matrix)	DGIR #:	
Incident Date (YYYY-MM-DD):	Incident Time (24 hour clock):		<input type="checkbox"/> PST <input type="checkbox"/> MST
INFORMATION OF PERSON REPORTING INCIDENT			B
Permit holder Name:		Reported by (name):	
Phone Number:		Alternate Number:	
E-mail:		Fax Number:	
INCIDENT DETAILS			C
SITE TYPE			D
<i>Select only one type.</i>			
<input type="checkbox"/> Well (Active)	<input type="checkbox"/> Well (Abandoned/Suspended)	<input type="checkbox"/> Remote Sump	
<input type="checkbox"/> Battery/Plant/Facility	<input type="checkbox"/> Tank Farm/Storage	<input type="checkbox"/> Pipeline	
<input type="checkbox"/> Riser (pipeline)	<input type="checkbox"/> Well (Drilling & Completions):	Rig Name:	
<input type="checkbox"/> Road or Road Structure: Name:		Location on road:	
<input type="checkbox"/> Other (specify):			



<b>OTHER LOCATION</b>	
<i>Any asset that does not apply to above such as a road, remote sump, borrow pit, etc. (A UTM location must be filled out in the Location Section.)</i>	
Location Type:	Location Description :
<b>LOCATION</b>	
Location of asset:	NTS _____ - _____ - _____ / _____ - _____ - _____ or DLS _____, SEC _____, TWP _____, RGE _____ W6M
UTM (NAD 83 Zone: _____)	_____ m easting _____ m northing
GPS: Latitude: _____	Longitude: _____
<b>AREA INFORMATION</b>	
Land Type: <input type="checkbox"/> Private Land <input type="checkbox"/> Crown Land	Field Name: _____
Access: <input type="checkbox"/> ATV <input type="checkbox"/> Helicopter <input type="checkbox"/> Four-wheel-drive <input type="checkbox"/> Two-wheel-drive <input type="checkbox"/> Unknown	
Name of road the asset is located on: _____	
Km where the incident occurred: _____	
Distance to nearest residence/public facility: _____	Nearest City/Town/Public Camp: _____
<b>CAUSE</b>	
<i>Check all that apply.</i>	
<input type="checkbox"/> Third Party	<input type="checkbox"/> Manufacturing Defect <input type="checkbox"/> Corrosion (internal, external)
<input type="checkbox"/> Employee (procedural, behavioural)	<input type="checkbox"/> Natural (weather, flood, fire) <input type="checkbox"/> Failure (materials, mechanical, equipment, system)
<input type="checkbox"/> Geological	<input type="checkbox"/> Over Pressuring Equipment
<input type="checkbox"/> Unknown at this time Explain: _____	
<input type="checkbox"/> Other Factors (specify): _____	
<b>CAUSE/REMEDIAL ACTIONS</b>	
Describe the cause and remedial actions in more detail:     	
<b>WEATHER</b>	
Weather Conditions:	<input type="checkbox"/> clear <input type="checkbox"/> cloudy <input type="checkbox"/> other (specify): _____
Wind Direction: From:	<input type="checkbox"/> N <input type="checkbox"/> NE <input type="checkbox"/> NW <input type="checkbox"/> E <input type="checkbox"/> SE <input type="checkbox"/> S <input type="checkbox"/> SW <input type="checkbox"/> W
Wind Strength:	<input type="checkbox"/> calm <input type="checkbox"/> moderate <input type="checkbox"/> strong <input type="checkbox"/> gusty
Temperature: _____	°C
Comments: _____	





## FORM D PERMIT HOLDER POST INCIDENT REPORT

*Must be submitted by the permit holder within 60 days for:*

1. Level 1, 2 or 3 emergency incident\*; **and**
2. **Any** pipeline incident.

\*Note: in addition to the above a permit holder may be required to complete and submit a "Form D" when requested by a representative of the Regulator.

DGIR# (if known):  
BCER Incident #:

**This report and accompanying documentation must be  
emailed electronically to [EMP@bc-er.ca](mailto:EMP@bc-er.ca)**

### PART A—PERMIT HOLDER

Permit Holder Name

Contractor(s) Name(s)

### PART B – DATE, TIME AND OIL AND GAS ACTIVITY IDENTIFICATION OF INCIDENT

Incident Date: (YYYY/MM/DD)

Incident Time: (24-hr system & time zone)

Well Authorization, Facility Id., Pipeline Project # and Segment #, Road # and Segment #, Other (Describe)

### PART C—SPILLS AND RELEASES *(Check all that apply)*

Type of Product	Volume Released (m <sup>3</sup> )	Volume Recovered (m <sup>3</sup> )	Type of Product	Volume Released (m <sup>3</sup> )	Volume Recovered (m <sup>3</sup> )
<input type="checkbox"/> Natural Gas (sweet)			<input type="checkbox"/> Produced Water		
<input type="checkbox"/> Natural Gas (sour)			<input type="checkbox"/> Fresh Water		
<input type="checkbox"/> Oil			<input type="checkbox"/> HVP fluids (ethane, propane, butane)		
<input type="checkbox"/> Condensate			<input type="checkbox"/> LVP fluids (pentane plus)		
<input type="checkbox"/> Emulsion					
<input type="checkbox"/> Other (specify product and CAS# or attach MSDS)					
<input type="checkbox"/> Other (specify product and CAS# or attach MSDS)					
<input type="checkbox"/> Other (specify product and CAS# or attach MSDS)					

Was there a fire?  Yes  No

Was there an explosion?  Yes  No

Was anyone directly exposed to the spill product?  Yes  No

Was medical treatment required?  Yes  No *(if yes, complete Part D)*

For any spills where clean-up cannot be completed within 30 days, an initial report / clean-up plan must be submitted within 30 days, with updates every 30 days following until clean-up has been completed.

Has the spill cleanup been completed?  Yes (attach relevant reports)  No (Interim Report or initial clean-up plan attached)

**PART D INJURY OR FATALITY?**     Yes     No

If yes, describe:

**PART E NARRATIVE OF INCIDENT** *Provide a complete description of the incident, including conditions and events leading up to, and following, the incident. Attach any additional information that may supplement the narrative such as 1) drawing of the incident site; 2) photographs; 3) schematics; 4) maps; 5) reports (drilling, servicing, etc.). **Attach additional sheets of narrative as required.***

**PART F INCIDENT RESPONSE**

Was the Emergency Response Plan Activated?     Yes     No

Was an Incident Action Plan Created?     Yes     No  
If Yes, attach a copy.

Was an Incident Command System Organization Chart Developed?     Yes     No    If Yes, attach a copy.

If the Emergency Response Plan was Activated, describe how the Emergency Response Plan was implemented and outline applicable steps taken to:

- Provide for the safety and health of all responders
- Protect public health and safety
- Protect the environment
- Protect government infrastructure
- Protect property



**PART I INCIDENT CAUSES** See the Emergency Management Manual, Appendix E: Post Incident Reports, for cause definitions. A full root cause analysis is required for all Level 2 and 3 Emergencies.

IMMEDIATE CAUSE (Check all that apply)	BASIC CAUSE (Check all that apply)	
<input type="checkbox"/> Defect and Deterioration	<input type="checkbox"/> Engineering and Planning	<input type="checkbox"/> Maintenance
<input type="checkbox"/> Corrosion and Cracking <input type="checkbox"/> Internal <input type="checkbox"/> External	<input type="checkbox"/> Procurement	<input type="checkbox"/> Tools and Equipment
<input type="checkbox"/> Equipment Failure	<input type="checkbox"/> Standards and Procedures	<input type="checkbox"/> Communication
<input type="checkbox"/> Incorrect Operation	<input type="checkbox"/> Supervision and Training	<input type="checkbox"/> Human Factors
<input type="checkbox"/> External Interference <input type="checkbox"/> Employee / Contractor <input type="checkbox"/> Third Party	<input type="checkbox"/> Natural and Environmental Factors	
<input type="checkbox"/> Natural Force Damage	<input type="checkbox"/> Unknown Causes (specify)	
<input type="checkbox"/> Construction	<input type="checkbox"/> Other Causes (specify)	
<input type="checkbox"/> Other Causes ( <i>specify</i> )		

Provide a justification for the causes selected and any additional details or explanation that will help the Regulator understand the basic cause(s) of this incident.

Attachment(s)

**PART J PREVENTIVE AND CORRECTIVE ACTIONS**

*Outline the changes made and the steps taken and to be taken to prevent a similar incident. This will address the basic causes, as applicable. Identify a schedule for completion. Include any relevant information outlining why the preventive actions are appropriate. See the Emergency Management Manual, Appendix E: Post Incident Reports, for more information.*

**PART K NAME OF PERSON CONDUCTING A COMPANY INCIDENT INVESTIGATION**

Name and Title

Address

Phone Number

Email

**PART L NAME AND TITLE OF COMPANY REPRESENTATIVE FILING REPORT**

Name

Title

Signature

Company

Address

Date (YYYY/MM/DD)

Phone number ( )

Email



## B1 Reception Centre Registration Log

Due to travel and time constraints, the company may not always be able to have a company employee at the Reception Centre before evacuees begin arriving. In this case this cover page can be included with the forms on the next 2 pages and sent to a representative at the Reception Centre to provide them with guidance on how to register and track evacuees until a company representative arrives.

### Evacuee registration guidelines

*[Insert Company Name]* requires your assistance with receiving evacuees at the following Reception Centre: \_\_\_\_\_

Your company contact is:

Name: \_\_\_\_\_ Position: \_\_\_\_\_ Contact Number: \_\_\_\_\_ Fax Number: \_\_\_\_\_

- 1) Record all evacuees as they arrive on the forms provided.
- 2) Provide all evacuees with the statement below and any other status updates as provided by your company contact.
- 3) Provide the evacuees with food and lodging as required.
- 4) Record if any evacuees choose to leave the Reception Centre (name, contact number, where are they going, etc.).
- 5) Continually update the company of any residences arriving at or leaving the Reception Centre so that they can follow up on any residents that are unaccounted for.

# B1 Reception Centre Registration Log



Date: \_\_\_\_\_ Responder Name: \_\_\_\_\_

Page \_\_\_\_\_ of \_\_\_\_\_ Responder Position: \_\_\_\_\_ Responders Phone No.: \_\_\_\_\_

Resident ID	Name (list all names in party)		# Of Occupants	Number arrived	Arrival time	Depart time	Destination phone # (where they can be reached)	Comments
	First	Last						

# B2 Resident Compensation Log

Resident's Name:	Home Address:	Home Telephone #:	Location of Land (LSD):
		Business Telephone #:	
Number of Residents Evacuated:	Evacuated to:	Telephone # While Evacuated:	

No.	Date	Location	Trans.	Accom.	Meals	Phone	Sundry	Total	Details of Expense
<b>Total Reported Expenses</b>									

Approved By: \_\_\_\_\_

Date: \_\_\_\_\_

# B2 Resident Compensation Log



Resident's Name:	Home Address:	Home Telephone #:	Location of Land (LSD):
		Business Telephone #:	
Number of Residents Evacuated:	Evacuated to:	Telephone # While Evacuated:	

No.	Date	Location	Trans.	Accom.	Meals	Phone	Sundry	Total	Details of Expense
<b>Total Reported Expenses</b>									

Approved By: \_\_\_\_\_

Date: \_\_\_\_\_

# B3 Resident Contact Log



Date: \_\_\_\_\_ Responder Name: \_\_\_\_\_

Page \_\_\_\_\_ of \_\_\_\_\_ Responder Position: \_\_\_\_\_ Responders Phone No.: \_\_\_\_\_

Time	Resident name	Resident ID	Shelter / Evacuate	Number of people		Assistance or transportation required?	Comments
				Inside	Outside		
			<input type="radio"/> Shelter <input type="radio"/> Evacuate			<input type="radio"/> Yes <input type="radio"/> No	
			<input type="radio"/> Shelter <input type="radio"/> Evacuate			<input type="radio"/> Yes <input type="radio"/> No	
			<input type="radio"/> Shelter <input type="radio"/> Evacuate			<input type="radio"/> Yes <input type="radio"/> No	
			<input type="radio"/> Shelter <input type="radio"/> Evacuate			<input type="radio"/> Yes <input type="radio"/> No	
			<input type="radio"/> Shelter <input type="radio"/> Evacuate			<input type="radio"/> Yes <input type="radio"/> No	
			<input type="radio"/> Shelter <input type="radio"/> Evacuate			<input type="radio"/> Yes <input type="radio"/> No	
			<input type="radio"/> Shelter <input type="radio"/> Evacuate			<input type="radio"/> Yes <input type="radio"/> No	
			<input type="radio"/> Shelter <input type="radio"/> Evacuate			<input type="radio"/> Yes <input type="radio"/> No	
			<input type="radio"/> Shelter <input type="radio"/> Evacuate			<input type="radio"/> Yes <input type="radio"/> No	
			<input type="radio"/> Shelter <input type="radio"/> Evacuate			<input type="radio"/> Yes <input type="radio"/> No	

# B3 Resident Contact Log



Time	Resident name	Resident ID	Shelter / Evacuate	Number of people		Assistance or transportation required?	Comments
				Inside	Outside		
			<input type="radio"/> Shelter <input type="radio"/> Evacuate			<input type="radio"/> Yes <input type="radio"/> No	
			<input type="radio"/> Shelter <input type="radio"/> Evacuate			<input type="radio"/> Yes <input type="radio"/> No	
			<input type="radio"/> Shelter <input type="radio"/> Evacuate			<input type="radio"/> Yes <input type="radio"/> No	
			<input type="radio"/> Shelter <input type="radio"/> Evacuate			<input type="radio"/> Yes <input type="radio"/> No	
			<input type="radio"/> Shelter <input type="radio"/> Evacuate			<input type="radio"/> Yes <input type="radio"/> No	
			<input type="radio"/> Shelter <input type="radio"/> Evacuate			<input type="radio"/> Yes <input type="radio"/> No	
			<input type="radio"/> Shelter <input type="radio"/> Evacuate			<input type="radio"/> Yes <input type="radio"/> No	
			<input type="radio"/> Shelter <input type="radio"/> Evacuate			<input type="radio"/> Yes <input type="radio"/> No	
			<input type="radio"/> Shelter <input type="radio"/> Evacuate			<input type="radio"/> Yes <input type="radio"/> No	
			<input type="radio"/> Shelter <input type="radio"/> Evacuate			<input type="radio"/> Yes <input type="radio"/> No	
			<input type="radio"/> Shelter <input type="radio"/> Evacuate			<input type="radio"/> Yes <input type="radio"/> No	
			<input type="radio"/> Shelter <input type="radio"/> Evacuate			<input type="radio"/> Yes <input type="radio"/> No	

# B4 Roadblock Log

Date: \_\_\_\_\_ Responder Name: \_\_\_\_\_

Page \_\_\_\_\_ of \_\_\_\_\_ Responder Position: \_\_\_\_\_ Responders Phone No.: \_\_\_\_\_

*Only emergency responders should be allowed to enter the Emergency Planning Zone (EPZ).*

Vehicle Type	License plate # and province / state	Name of driver (if available)	# of people in vehicle	Time entering Zone	Time Exiting Zone	Comments (record all vehicles turned away)

# B4 Roadblock Log



Vehicle type	License plate # and province / state	Name of driver (if available)	# of people in vehicle	Time entering zone	Time Exiting zone	Comments (record all vehicles turned away)

DATE: \_\_\_\_\_

TIME: \_\_\_\_\_

# EVACUATION NOTICE

*[Insert Company Name]* has an emergency at its nearby location.

**As a safety precaution, please leave the area in a  
(north / east / south / west) direction and proceed to the  
Reception Centre located at**

\_\_\_\_\_.

*[Insert Company Name]* representatives will be available at the Reception Centre to address your questions or concerns.

For assistance, call *[Insert Company Name]* at

\_\_\_\_\_.

**Thank you for your cooperation.**



# B6 Early Notification / Voluntary Evacuation Phone Message



Before calling, determine a safe evacuation route for the residents to travel, away from the emergency hazard area, upwind if possible, towards the reception centre.

<p>Hello, this is _____ <i>(your name)</i> _____ calling from _____ <i>(company name)</i> _____ .</p> <p>Is this the _____ <i>(name of residence / business)</i> _____ at _____ <i>(telephone number)</i> _____ ?</p> <p>_____ <i>(company name)</i> _____ is responding to a <i>(potential)</i> emergency at _____ <i>(location)</i> _____ in your area.</p> <p>You are in no danger at this time. All efforts are being made to resolve the problem and this phone call is only to inform you and provide you with an early notification.</p> <p>To help us understand and your immediate needs we need to know:</p>
<p><b>How many people are at your location now?</b></p> <p><i>Adults</i> _____</p> <p><i>Children</i> _____</p>
<p><b>Do you wish to leave your residence at this time?</b></p> <p><b>If Yes</b> Please travel in a <u>north / east / south / west</u> direction to our reception centre located at: _____</p> <p><b>If No</b> Please standby for further contact. Please do not use your telephone for outgoing calls as this may prevent us from contacting you with updated information or when the problem has been eliminated.</p>
<p><b>If you have urgent questions, please contact</b> _____ <i>(company name)</i> _____ <b>at</b> _____ <i>(telephone number)</i> _____ .</p> <p><b>Thank you for your cooperation.</b></p>

*(Pass on all information regarding this call to the Public Safety Group Supervisor immediately)*

# B6 Early Notification / Voluntary Evacuation Phone Message

---



## B7 Shelter-In-Place Phone Message

Hello, this is \_\_\_\_\_ (*your name*) \_\_\_\_\_ of \_\_\_\_\_ (*company name*) \_\_\_\_\_.

Is this the \_\_\_\_\_ (*name*) \_\_\_\_\_ residence at \_\_\_\_\_ (*telephone number*) \_\_\_\_\_?  
\_\_\_\_\_ (*company name*) \_\_\_\_\_ is responding to a (*potential*) emergency at \_\_\_\_\_ (*location*) \_\_\_\_\_ in your area.

For your safety, it is extremely important that you, and those with you, stay indoors until the potential hazard no longer exists, or you are advised to evacuate.

To help us understand your immediate needs, we need to know:

**How many people are at your location now?**

Adults \_\_\_\_\_

Children \_\_\_\_\_

Is there anyone in your household that you cannot contact to inform them of the situation and advise them to get in doors or stay out of the area?

Yes     No

**If Yes**    *Whom?* \_\_\_\_\_

*Location of the person(s)* \_\_\_\_\_

We will send someone to find them as soon as possible.

**Do you have children in school at this time?**

Yes     No

**If Yes**    *What school?* \_\_\_\_\_

*Children's names* \_\_\_\_\_

We will contact the school to ensure the safety of your children. Buses will be directed to leave the area immediately. If school is in session, your children will be redirected to the reception centre by their regular bus driver when the school day is over.

**Do you have the "Shelter-in-Place" instructions previously provided to you by \_\_\_\_\_ (*company name*) \_\_\_\_\_?**

Yes     No

**If Yes**    Please follow the Shelter-in-Place instructions located inside the resident pamphlet.

**If No**    *Verbally walk the resident through the Shelter-in-Place instructions on the next page.*

**Do you understand what I have told you?**

Is there an alternate number we can contact you at? \_\_\_\_\_

If you have any urgent questions, please contact \_\_\_\_\_ (*company name*) \_\_\_\_\_ at \_\_\_\_\_ (*telephone number*) \_\_\_\_\_.

Thank you for your cooperation.

*(Pass on all information regarding this call to the Public Safety Group Supervisor immediately)*

## Shelter-In-Place Instructions

For your safety:

- Immediately gather everyone indoors and stay there
- Close and lock all windows and outside doors
  - If convenient, tape the gaps around the exterior door frames
- Leave open all inside doors
- Extinguish indoor wood burning fires
  - If possible, close flue dampers
- Turn off appliances or equipment that either:
  - Blows out or uses indoor air, such as:
    - Bathroom and kitchen exhaust fans
    - Built-in vacuum systems
    - Clothes dryers
    - Gas fireplaces and gas stoves
  - Sucks in outside air, such as:
    - Heating, ventilation and air conditioner (HVAC) systems for apartments, commercial or public facilities
    - Fans for heat recovery ventilators or energy recovery ventilators (HRV / ERV)
- Turn down furnace thermostats to the minimum setting and turn off air conditioners
- Avoid using the telephone, except for emergencies, so that you can be contacted by company emergency response personnel
- Call the company emergency numbers you have been provided:
  - If you are experiencing symptoms or smelling odours (so that we can address your concerns and adjust our response priorities)
  - If you have contacted fire, police or ambulance (so that we can coordinate our response)
- Stay tuned to local radio and television for possible information updates
- Do not leave your residence, even if you see people outside, until you are told to do so
- After the hazardous substance has passed through the area you will receive an “all-clear” message from the company emergency response personnel. You may also receive, if required, instructions to:
  - Ventilate your building by opening all windows and doors; turning on fans and turning up thermostats. During this time the air outside may be fresher and you may choose to leave your building while ventilating.
  - Once the building is completely ventilated return all equipment to normal settings & operation.
- Do not leave your sheltered location or attempt to start any vehicle until a company representative advises you that the area is safe.

**If you are unable to follow these instructions, please notify company emergency response personnel.**

# B8 Evacuation Phone Message



Before calling, determine a safe evacuation route for the residents to travel, away from the emergency hazard area, upwind if possible, towards the reception centre.

Hello, this is _____ <i>(your name)</i> _____ of _____ <i>(company name)</i> _____.	
Is this the _____ <i>(name)</i> _____ residence at _____ <i>(telephone number)</i> _____ ?	
_____ <i>(Company name)</i> _____ is responding to a <i>(potential)</i> emergency at _____ <i>(location)</i> _____ in your area.	
For your safety, it is extremely important that you and your family leave your residence immediately and travel in a <i>north / east / south / west</i> direction to our reception centre located at: _____	
To help us understand your immediate needs, we need to know:	
<b>How many people are at your location now?</b>	
<i>Adults</i> _____	
<i>Children</i> _____	
Is there anyone in your household that you cannot contact to inform them of the situation and advise them to evacuate away from the area?	
<input type="checkbox"/> Yes <input type="checkbox"/> No	
<b>If Yes</b>	<i>Whom?</i> _____
	<i>Location of the person(s)</i> _____
We will send someone to find them as soon as possible.	
<b>Do you have children in school at this time?</b>	
<input type="checkbox"/> Yes <input type="checkbox"/> No	
<b>If Yes</b>	<i>What school?</i> _____
	<i>Children's names</i> _____
We will contact the school to ensure the safety of your children. Buses will be directed to leave the area immediately. If school is in session, your children will be redirected to the reception centre by their regular bus driver when the school day is over.	
<b>Do you require evacuation / transportation assistance?</b>	
<input type="checkbox"/> Yes <input type="checkbox"/> No	
<b>If Yes</b>	We are sending someone to assist you. Please stay indoors and close all doors and windows until a Rover or the local police arrive to evacuate you.
<b>If No</b>	<i>Provide the resident with:</i>
	<input type="checkbox"/> <i>Directions to safely travel to the reception centre</i>
	<input type="checkbox"/> <i>A list of items to bring with them to the reception centre (medications, cell phone, etc.)</i>
	<input type="checkbox"/> <i>An idea of how long they may be expected to stay at the reception centre</i>
	<input type="checkbox"/> <i>The option to bring their house pets to the reception centre</i>
Please contact _____ <i>(company name)</i> _____ if you are unable to make it to the reception centre for any reason. Please keep your phone line free so that we can contact you if necessary.	
Is there an alternate number we can contact you at? _____	
A company representative at the reception centre will address any questions you may have and will make arrangements for your temporary accommodations. Do you understand everything I have told you? Are you leaving immediately?	
<b>If you have any urgent questions, please contact _____ <i>(company name)</i> _____ at _____ <i>(telephone number)</i> _____.</b>	
<b>Thank you for your cooperation.</b>	

*(Pass on all information regarding this call to the Public Safety Group Supervisor immediately)*

## Evacuation is the primary protection measure

- The Telephone Notification Leader will assemble a team of phoners. There will be approximately 1 telephoner/6-7 residences. The OCC and the Grande Prairie Office may be used as telephoning stations.
- Individuals inside the identified EPZ with a Special Needs designation will be notified at a Level 1 Emergency and offered voluntary evacuation.
- At a Level 2 Emergency evacuation becomes mandatory and residents and businesses will be contacted by telephone or by a personal visit. Transients will be located and evacuated by Rovers.
- If the EPZ includes a portion of a subdivision or town, the whole subdivision or town must be evacuated.
- Evacuees will be given directions to take when leaving the EPZ.
- Residents and businesses will be required to provide their own transportation for evacuation, however, Company representatives (Rovers) will be dispatched to assist those residents and businesses that do not have transportation and require assistance.
- Roadblocks will be established at the perimeter of the EPZ to control the flow of traffic coming into or leaving the area.
- Contact the principals of area schools and the associated area School Bus Coordinators. Advise the school administration of road closures.
- All evacuees will be asked to proceed to the designated Reception Centre where they will be met by Ovintiv's Reception Centre Representatives who will record their arrival, answer their questions, and address their needs for food and accommodation. Once registered, evacuees may leave the Reception Centre.
- Ovintiv's Public Protection Chief will arrange communication with all evacuees on a regular basis to ensure an informed public.

# C1 Preliminary Media Statement



## Core Emergency Response Plan

Date:(YY/MM/DD)	Responder Name:
Responder Position:	Responder Phone No.:

We can confirm an incident occurred at Ovintiv's [**insert facility/site**]. Our team in the field is actively responding and we are gathering more information about the nature and severity of the incident. An Ovintiv spokesperson will provide more information when it is available.

**You can contact our media spokesperson at (281) 210-5253.**

**Contact:**

\_\_\_\_\_ Office: \_\_\_\_\_

\_\_\_\_\_ Fax: \_\_\_\_\_

*Note: Only the **Media Spokesperson** designated by the Incident Commander is to provide any specific information to the public or the media.*



# C2 Media Contact Log



Date: \_\_\_\_\_ Responder Name: \_\_\_\_\_

Page \_\_\_\_\_ of \_\_\_\_\_ Responder Position: \_\_\_\_\_ Responders Phone No.: \_\_\_\_\_

If you feel you are not the appropriate person to be answering the media agencies questions, use the following series of statements.

"[Insert Company Name] has an Information Officer to answer all media questions."  
 "May I request the following information to expedite your request?" (complete the form below).  
 "Thank you. [Insert Company Name] appreciates your cooperation and I will pass on this information to the appropriate person."

Time	Call To	Call From	Media Outlet	Reporter / Contact Name	Telephone Numbers		Remarks / Information Required
					Work	Fax	

Document all key events, conversations, and meetings on this form. Where lengthy notes are necessary, use additional copies or the back of the page.

# C2 Media Contact Log



Time	Call To	Call From	Media Outlet	Reporter / Contact Name	Telephone Numbers		Remarks / Information Required
					Work	Fax	

# C3 Government Agency Contact Log



Date: \_\_\_\_\_ Responder Name: \_\_\_\_\_

Page \_\_\_\_\_ of \_\_\_\_\_ Responder Position: \_\_\_\_\_ Responders Phone No.: \_\_\_\_\_

If you feel you are not the appropriate person to be answering the media agencies questions, use the following series of statements.

**"[Insert Company Name] has a Government Liaison to answer all media questions."**

**"May I request the following information to expedite your request?" (complete the form below).**

**"Thank you. [Insert Company Name] appreciates your cooperation and I will pass on this information to the appropriate person."**

Time	Call To	Call From	Agency	Contact Name	Telephone Numbers		Remarks / Comments
					Work	Fax	

Document all key events, conversations, and meetings on this form. Where lengthy notes are necessary, use additional copies or the back of the page.



# C4 Media Centre Site



## Location

Address: \_\_\_\_\_

City / Town: \_\_\_\_\_

Phone #: \_\_\_\_\_

Contact  
Name: \_\_\_\_\_

Office #: \_\_\_\_\_

Home #: \_\_\_\_\_

## Map or Directions to Site

A large empty rectangular box intended for a map or directions to the site.



---

# Appendices

<b>Appendix A: ERP Scope, Training and Plan Maintenance .....</b>	<b>1</b>
Scope .....	1
Plan Objectives.....	1
Purpose .....	1
HSE Policy.....	3
Training Requirements .....	5
Plan Maintenance.....	6
<b>Appendix B: Incident Command Post (ICP) .....</b>	<b>9</b>
Communication Methods Between Command Posts - British Columbia .....	9
ICP Activation and Setup .....	10
<b>Appendix C: Toxic Gases .....</b>	<b>12</b>
Hydrogen Sulphide (H <sub>2</sub> S) .....	12
Sulphur Dioxide (SO <sub>2</sub> ) .....	16
<b>Appendix D: Key Elements of the Incident Command System (ICS).....</b>	<b>20</b>
Management by Objectives.....	20
Unity and Chain of Command .....	20
Organizational Flexibility.....	21
Span of Control.....	21
Common Terminology .....	21
Incident Action Plan (IAP) .....	21
Integrated Communications .....	21
Establishment and Transfer of Command.....	22
Resources Management .....	22
Summary of Responsibilities .....	22
<b>Appendix E: Land Descriptions.....</b>	<b>23</b>
Dominion Land Survey (DLS) System.....	23
National Topographic System (NTS).....	24
<b>Appendix F: ERP Reference Material .....</b>	<b>25</b>
Acronyms.....	25
Glossary of Terms .....	26

---

This page is intentionally left blank

---

# Appendix A: ERP Scope, Training and Plan Maintenance

## Scope

This plan defines the emergency response process related to all hazards affecting petroleum operations. This Emergency Response Plan (ERP) outlines the process for an Alert/Minor, Level-1, Level-2, or Level-3 emergency for any jurisdiction or incident type.

## Plan Objectives

The primary objective of this Emergency Response Plan (ERP) is to define the incident management system and organizational structure, process and tools to respond effectively to all incidents regardless of size or complexity. It has been designed to be intuitive and have natural process flow utilizing the Incident Command System (ICS) and to comply with applicable regulations, standards, and industry best practices.

## Purpose

This ERP clearly defines emergency response team roles, functions and duties to protect people, environment, and assets during an incident. This plan clarifies the following:

- Overall Incident Command System (ICS) response organization.
- Incident Command System (ICS) Roles and responsibilities.
- Guidance to determine the Alert or Emergency Level.
- Mechanisms to activate the ERP.
- Notification /communication requirements to stakeholders (public /government /responders).
- Documentation tools for accurate records management of events and decisions during an event.
- Guidance for post-emergency actions.

The intent of this Emergency Response Plan (ERP) is to define effective measures in place to:

- Notify and protect the workers and the public.
- Minimize environmental impact.
- Minimize asset and property loss.
- Regain steady state of operations.
- Minimize emergency response time.
- Maximize response effectiveness.
- Coordinate with government agencies and stakeholders.
- Minimize business and reputational impact.

This manual outlines the framework, tools and reference materials to facilitate a prompt, safe, efficient and properly managed response to all incidents regardless of size or complexity. Therefore this plan provides employees and contractors with practical tools that will guide them through the Preparedness and Response principles of Emergency Management.

## Emergency Management Process Flow

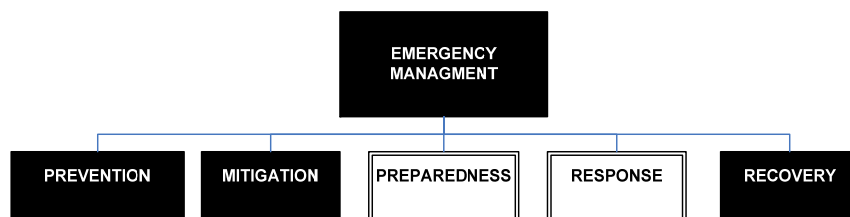

This page is intentionally left blank

# Health & Safety Policy

Ovintiv™ Inc. recognizes that a robust health and safety culture contributes to growing shareholder value and that strong safety performance is both a foundational value and a common goal of Ovintiv's leadership and workforce. We believe occupational injuries and illnesses are preventable, and we strive for a workplace free of recognized hazards. This Health & Safety Policy articulates our commitment to a safe and healthy workplace where our workforce is empowered and expected to comply with the provisions of this policy.

Ovintiv will:

- comply with health and safety laws and regulations, requirements and industry standards applicable to our activities
- ensure all personnel working on an Ovintiv location have the authority, responsibility and support to stop work when an unsafe situation is recognized or suspected
- identify and assess health and safety hazards arising from our activities and adopt technically sound and economically practicable measures to eliminate or mitigate the potentially negative health and safety impacts associated with such activities
- ensure that our workforce understands that working safely is a condition of employment and that all workers are responsible for their own health and safety as well as the health and safety of those around them
- expect our workforce to comply with our established health and safety practices and provide the tools and training for them to do so
- communicate to our workforce our expectations regarding health and safety performance and the necessity for adherence to these expectations
- ensure the competency of our workforce is verified and maintained in support of Ovintiv's health and safety programs, initiatives, performance and culture
- commit to the continual improvement of our safety programs by setting health and safety objectives and targets, and measure and monitor our performance through regular inspections, audits and investigation of incidents. Use these results to develop, communicate and implement appropriate corrective actions geared toward lasting improvement
- commit to safe and courteous driving by complying with the Driving Safety Program
- integrate health and safety stewardship into our business planning and decision-making processes
- commit to protect the health and safety of our workforce and the public
- commit to always doing what is right when it comes to the health and safety of our workforce and the

public; if it cannot be done safely it should not be done at all.

Ovintiv is committed to implementing this Health & Safety Policy through the active participation of our leadership and workforce, and through the integration of Ethos, our Operations Management System, into our day-to-day operations and decision-making processes.

Updated September 15, 2021

## Appendix A: ERP Scope, Training and Plan Maintenance, continued

### Training Requirements

Frequency / Action	As Required	Annually*	Every Three (3) Years**	Every Five (5) Years***
<b>Training</b>				
Employee Orientation New / Transfer	✓			
On-the-job Training	✓			
Response Discussion During Pre-Job Meetings	✓			
Drills	✓			
Tabletop Exercise		✓		
Communication / Partial Mobilization Exercises		one of these exercises		
Major (Full Scale) Exercise	✓ Start-up of facility or transmission line (BCER)		✓	✓
Post Incident (Actual) Review	✓			
ERP Review / Self Audit		✓		

\* Must be held annually.

\*\* CSA Z246.2-18, CER, BCER & AER requires Major Exercises be held every three (3) years.

\*\*\* Environment & Climate Change Canada (ECCC) requires Major Exercises be held every five (5) years for facilities with E2 required substances.

## Appendix A: ERP Scope, Training and Plan Maintenance, continued

### Plan Maintenance

#### Responsibility

The licensee is responsible to ensure that an ERP is created for all provincial and federally regulated oil and gas activities (i.e. sour operations, HVP pipelines, cavern storage facilities, etc.), they are maintained regularly, and any updates are disseminated to the regulatory agency and other plan holders as required. In order for this to occur the following responsibilities are designated:

- Each individual plan holder is responsible for ensuring their assigned manuals are current, all updates are applied / downloaded / inserted, and any errors or omissions are reported to a supervisor.
- Each Area Manager is responsible for ensuring that an annual review of their ERP is conducted. The ERP Revision Request Form is located in this section and can be used to track this information and provide documentation in the case of an ERP assessment. Any of the following events will trigger an ERP update:
  - Changes to emergency information (e.g., contact phone numbers).
  - New mapping information.
  - New resident information.
  - Changes to response staff information or response capabilities.
  - Facility additions such as well or pipeline tie-ins that do not require submission of a supplement. Before starting operations, the duty holder is expected to update its approved ERPs with information about on- and off-site emergency response team personnel.
- Any requests for revisions to this plan should be forwarded to the applicable Area Manager for review. These revisions will be discussed with the company's Emergency Response Program Coordinator and H<sub>2</sub>Safety Services Inc. Any significant changes including those resulting from exercises and incidents will require immediate updates sent out to all plan holders; less significant changes will be implemented during the ERP's next annual update.
- The company's Emergency Response Program Coordinator is responsible for ensuring that the plans and distribution lists are updated, training is performed, and new projects are included in the plan. Information in this plan will be verified and updated at least once a year.
- Old manuals must be sent to H<sub>2</sub>Safety Services Inc. or destroyed. If a plan holder no longer requires their manual (job changes, position changes, etc.), it must be returned to the company's Emergency Response Program Coordinator to be tracked, reassigned, or destroyed.

The licensee must distribute changes in information that are instrumental to implementing the ERP to all required plan holders.

Errors identified in the ERP by the regulatory agency, licensee, and other party must be corrected immediately upon identification.

#### Modifications to New or Existing Operations

The licensee must submit a supplement for review and approval to the regulatory agency for all newly added wells, pipelines, well / pipeline tie-ins, facilities and operating areas prior to commencement of operations if there are new surface developments within the Emergency Planning Zone. For example, the EPZ for a new pipeline tie-in does not fall entirely within the existing Emergency Planning Zone and impacts a new residence / public facility / trapper cabin / etc. that was not previously included in the Emergency Response Plan. The licensee must conduct a public involvement program for all new members of the public. Before any new or major modifications to an existing facility / pipeline are brought on-stream, any additions or changes will be added to the Emergency Response Plan. If required, a site specific Emergency Response Plan will be developed. Meetings to review response plan requirements must be held before major facility modifications are commissioned.

## Appendix A: ERP Scope, Training and Plan Maintenance, continued

### ERP Revision Request Form

Plan Holder Name / Title / Company: \_\_\_\_\_

ERP Name: \_\_\_\_\_

Manual Number: \_\_\_\_\_

If any of the following items have changed, please check the box beside it and provide a description of the change in the space provided:

- Company information
- Mapping information
- Resident contact information
- Response staff information or capacity changes
- Facility additions, such as well or pipeline tie-ins
- Other

Description of the change:

*Please attach additional pages and/or support documentation as required.*

---

---

---

---

---

---

---

---

---

---

Please return the completed checklist to:

Ovintiv

Attn: Tanner Strangway – Senior Emergency Response Advisor

500 Centre Street SE (Box 2850)

Calgary, AB T2G 1A6

Email: [tanner.strangway@ovintiv.com](mailto:tanner.strangway@ovintiv.com)

Fax: 403-645-3400

This page is intentionally left blank

## Appendix B: Incident Command Post (ICP)

### Communication Methods Between Command Posts - British Columbia

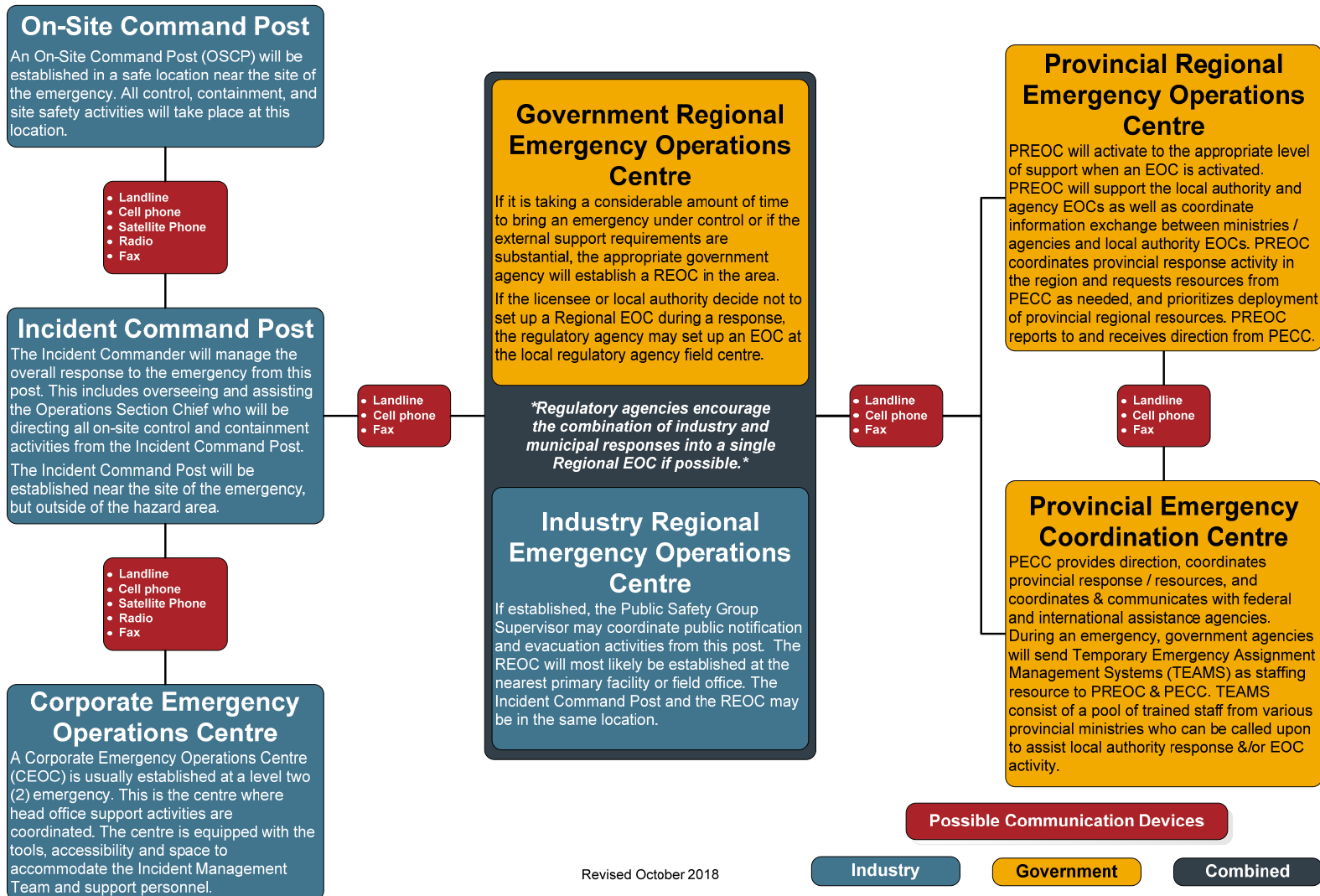

Revised October 2018

## Appendix B: Incident Command Post (ICP), continued

### ICP Activation and Setup

The Incident Command Post is activated by the Incident Commander.

The following tasks must be addressed once the ICP has been activated:

Position	Task
<b>Incident Commander</b>	<ul style="list-style-type: none"> <li><input type="checkbox"/> Establish briefings with the Field Response Team (FRT).</li> <li><input type="checkbox"/> Ensure staffing is adequate for the task(s).</li> <li><input type="checkbox"/> Consider the time difference, if applicable, and determine how time will be communicated throughout the incident.</li> </ul>
<b>Safety Officer</b>	<ul style="list-style-type: none"> <li><input type="checkbox"/> Ensure the room / floor / building is secure.</li> <li><input type="checkbox"/> Ensure a safe work area, i.e. remove clutter or cords causing slips, trips, falls, etc.</li> </ul>
<b>Information Officer</b>	<ul style="list-style-type: none"> <li><input type="checkbox"/> Notify the receptionist that there is an incident. Provide details of what message should be given out to the public and media, as well as where to direct incoming calls.</li> <li><input type="checkbox"/> Ensure inbound and outbound calls received or made are centrally logged.</li> <li><input type="checkbox"/> Ensure responders have their office phones forwarded to their cell phones.</li> </ul>
<b>Logistics / IT Support</b>	<ul style="list-style-type: none"> <li><input type="checkbox"/> Turn on all computers; ensure the relevant systems are operational and that they all have internet/email access.</li> <li><input type="checkbox"/> Bring up any ERP related electronic tools (ie; <b>H2CommandCentre</b>) and ensure they are working and that they can all be displayed on various projectors / screens as required.</li> <li><input type="checkbox"/> Check that printers are connected to the computers and working. Print a test page to confirm.</li> <li><input type="checkbox"/> Check that the fax machine is setup and working.</li> <li><input type="checkbox"/> Check that any phone conferencing systems are set up and working.</li> <li><input type="checkbox"/> Ensure that telephone lines are available and active.</li> <li><input type="checkbox"/> Ensure TVs are working properly and set up to local news or CNN.</li> <li><input type="checkbox"/> Obtain any additional equipment as required.</li> </ul>
<b>Logistics / Security</b>	<ul style="list-style-type: none"> <li><input type="checkbox"/> Ensure the room/floor/building is secure. Arrange for additional security if required.</li> <li><input type="checkbox"/> If the location of the Incident Command Post is closed to general staff, provide a list of staff needing access clearance to the meeting area.</li> <li><input type="checkbox"/> The following supplies should be available: notepaper, pens, printer cartridges and paper, documentation forms, dry erase markers, staplers and staples, spare power bars and extension cords, etc.</li> <li><input type="checkbox"/> Arrange for refreshments (coffee, food, water, etc.) for those working there, as well as sleeping space if required.</li> <li><input type="checkbox"/> Ensure there are sufficient tables and chairs for the team.</li> </ul>

## Appendix B: Incident Command Post (ICP), continued

### ICP Activation and Setup, continued

Position	Task
<b>Planning / Documentation</b>	<ul style="list-style-type: none"> <li><input type="checkbox"/> Determine which emergency response plans and other ERP tools are needed and pull them out to be readily accessible.</li> <li><input type="checkbox"/> Determine what laminated maps and charts are going to be utilized and put them up on the wall with dry erase markers. Set up the white boards and roles chart.</li> <li><input type="checkbox"/> Ensure clocks are displaying the correct time, including any clocks with a different time zone.</li> <li><input type="checkbox"/> As each person arrives: provide them with a vest, provide them with a print out of the Initial Emergency Report Form, ensure they synchronize their watches and ensure they check in with their assigned supervisor.</li> <li><input type="checkbox"/> As team members arrive, write their name in the appropriate position on the Field Response Team Assignment Chart.</li> <li><input type="checkbox"/> Pass out documentation forms and provide an overview of the documentation process.</li> <li><input type="checkbox"/> Ensure the latest contact list for Field Response Team members are available.</li> <li><input type="checkbox"/> Begin documenting all actions, decisions and major events. Start-up <b>H<sub>2</sub>CommandCentre</b> if available.</li> <li><input type="checkbox"/> Continually update the laminated maps and charts as information becomes available (Field Response Team Assignment Chart, Emergency Status Board, etc.).</li> <li><input type="checkbox"/> Post a schedule of events, including shift changes and status updates.</li> </ul>

### Incident Command Post Briefings

Once the ICP has been activated and team members arrive, the Incident Commander or Deputy needs to conduct an initial briefing to provide the team with the status of the situation, establish operational periods for the ICP, establish a meeting schedule for both a planning meeting and periodic briefings and outline broad goals to guide the ICP throughout the emergency.

In addition to periodic briefings for status updates, the Incident Commander also has to conduct a meeting once the approved Incident Action Plan is in place. This meeting will outline the planned objectives and tasks and will ensure that resources required for implementation of the action plan are in available or en route.

At the end of each operational period, all departing members of the Field Response Team will be debriefed and must brief their replacements.

### Documentation

It is critical to ensure that all ICP documentation is compiled, properly stored and readily available after the event. Proper documentation will aid in investigations, inquiries, debriefs and support for financial claims and budgets. Everything that happens during the Response/Recovery Operations should be recorded at the ICP. The forms at the back of this manual are designed to aid in this process

## Appendix C: Toxic Gases

### Hydrogen Sulphide (H<sub>2</sub>S)

#### Background

Hydrogen sulphide (H<sub>2</sub>S) is a flammable, colourless gas with a characteristic odour of rotten eggs that people can smell at low levels. It is also known as hydrosulphuric acid and sewer gas. H<sub>2</sub>S occurs naturally in crude petroleum, natural gas, volcanic gases and hot springs. It can also result from bacterial breakdown of organic matter. Industrial sources include emissions from industrial paper plants; combustion of coal, fuel oil and natural gas (including gas flares); kraft paper mills; tanneries; and emissions from sewers and waste treatment facilities. Cigarette smoke is also a source of hydrogen sulphide.

H<sub>2</sub>S is released primarily as a gas and spreads in the air. Its residence time in the atmosphere ranges from about one day to more than 40 days, depending on ambient temperature and other atmospheric variables, including humidity, sunshine and presence of other pollutants. The decreased temperatures and decreased levels of hydroxyl ions in northern regions in winter increase the residence time. When released H<sub>2</sub>S gas is ignited, it will change into sulphur dioxide (SO<sub>2</sub>), be carried into the atmosphere and dispersed over a larger area at lower concentrations.

#### Signs and Symptoms

Exposure to hydrogen sulphide may cause irritation to the eyes, nose or throat. It may also cause difficulty in breathing for some asthmatics. Brief exposures to high concentrations of hydrogen sulphide can cause a loss of consciousness and possibly death. In most cases, the person appears to regain consciousness without any other effects. However, in some individuals, there may be permanent or long-term effects such as headaches, poor attention span, poor memory and poor motor function. No health effects have been found in humans exposed to typical environmental concentrations of hydrogen sulphide (0.00011-0.00033 ppm).

#### Acute Exposure Effects

The effects on humans will vary depending on the duration and H<sub>2</sub>S concentration of exposure. The health effects of acute exposure to H<sub>2</sub>S are shown in the following table. Acute exposure reflects a range from a few seconds up to several weeks.

#### Hydrogen Sulphide Toxicity Table (BC Regulations)

Concentration (ppm)	Effects
Less than 1	Most people smell "rotten eggs".
3 – 5	Odour is strong.
20 – 150	Nose and throat feel dry and irritated. Eyes sting, itch or water and "gas eye" symptoms may occur. Prolonged exposure may cause coughing, hoarseness, shortness of breath and runny nose.
150 – 200	Sense of smell is blocked (olfactory fatigue).
200 – 250	Major irritation of the nose, throat and lungs, along with headache, nausea, vomiting and dizziness. Prolonged exposure can cause fluid buildup in the lungs (pulmonary edema), which can be fatal.
300 – 500	Symptoms are the same as above, but more severe. Death can occur within 1-4 hours of exposure.
Above 500	Immediate loss of consciousness. Death is rapid, sometimes immediate.

*Adapted from Hydrogen Sulfide in Industry, WorkSafe BC February 2010*

## Appendix C: Toxic Gases, continued

### Chronic Exposure Effects of Hydrogen Sulphide

Chronic effects from H<sub>2</sub>S exposure is a developing area of research. Chronic exposure may inflame and irritate the upper respiratory tract.

#### Medical treatment for hydrogen sulphide exposure

*(Please note: This information was provided by a medical source other than the Provincial Regional Health Authorities. See Hydrogen Sulphide (H<sub>2</sub>S) Guidelines - Revised November 2000)*

#### Guidelines for in Hospital Assessment/Treatment of Possible Hydrogen Sulphide Exposure

This is provided to assist medical staff in assessing a worker who has a possible or actual H<sub>2</sub>S exposure.

Section I provides information on H<sub>2</sub>S

Section II summarizes possible health effects, which should be evaluated at the time of presentation

Section III depicts a summary of possible clinical management

Section IV provides a guideline regarding return to work (RTW) considerations

#### I. Hydrogen sulphide

H<sub>2</sub>S is a colourless gas. It is heavier than air and tends to flow in ditches, trenches and low-lying areas.

H<sub>2</sub>S is clearly recognizable in small concentrations at around one part per million (ppm) by its characteristic rotten egg smell.

At concentrations of about 150 ppm in the air, or after prolonged exposure to lower concentrations, the olfactory sense is paralyzed and the presence of H<sub>2</sub>S can no longer be detected by odour.

#### II. Health effects of hydrogen sulphide

H<sub>2</sub>S can be rapidly fatal. It acts by paralyzing the respiratory control centre in the brain and by inhibiting cellular respiration.

Hydrogen sulphide is a mucous-membrane and respiratory-tract irritant. Pulmonary edema, which may be immediate or delayed, can occur after exposure to high concentrations.

#### Acute exposure may include the following symptoms and signs:

##### Central Nervous System

CNS injury is immediate and significant after exposure to hydrogen sulphide. At high concentrations, only a few breaths can lead to loss of consciousness, coma, respiratory paralysis, seizures, and death. CNS stimulation may precede CNS depression. Stimulation manifests as excitation, rapid breathing, and headache; depression manifests as impaired gait, dizziness, and coma, possibly progressing to respiratory paralysis and death. In addition, decreased ability to smell occurs at 100 to 150 ppm.

##### Respiratory

Inhaled Hydrogen sulphide initially affects the nose and throat. Low concentrations (50 ppm) can rapidly produce irritation of the nose, throat, and lower respiratory tract. Pulmonary manifestations include cough, shortness of breath, and bronchial or lung hemorrhage. Higher concentrations can provoke bronchitis and cause accumulation of fluid in the lungs, which may be immediate or delayed for 24 hours or more. Lack of oxygen may result in cyanosis.

## Appendix C: Toxic Gases, continued

### Medical Treatment for Hydrogen Sulphide Exposure, continued

#### Cardiovascular

High dose exposure may cause insufficient cardiac output, irregular heartbeat and conduction abnormalities.

#### Renal

Although very unlikely, transit renal effect may include blood, casts, and protein in the urine. Renal failure as a direct result of hydrogen sulphide toxicity has not been described, although it may occur secondary to cardiovascular compromise.

#### Gastrointestinal

Symptoms may include nausea and vomiting.

#### Dermal

Prolonged or massive exposure may cause burning, itching, redness and painful inflammation of the skin.

#### Ocular

Eye irritation may result in inflammation (i.e. kerato-conjunctivitis) and clouding of the eye surface. Symptoms include blurred vision, sensitivity to light, and spasmodic blinking or involuntary closing of the eyelid.

#### Potential Sequelae

Inflammation of the bronchi can be a late development. Survivors of severe exposure may suffer psychic disturbances and permanent damage to the brain and heart.

### III. Approach to the worker with suspected hydrogen sulphide exposure

Although this document refers only to H<sub>2</sub>S, it is important for the clinician to keep in mind the possibility of co-exposure to numerous other agents. Sulphur dioxide may have been present if there has been combustion of hydrogen sulphide. Sulphur dioxide does not cause loss of consciousness but is a respiratory tract irritant. Therefore, the management of sulphur dioxide intoxication is similar to that for hydrogen sulphide. Other agents capable of causing asphyxia include carbon monoxide (toxic asphyxia) as well as a wide array of gases that act as simple asphyxiants (carbon dioxide, methane, nitrogen, etc.) by displacing oxygen. Finally, other conditions (MI, syncope, seizure, etc.) that may cause sudden collapse must be investigated and managed as appropriate.

#### History

The history is the key to the diagnosis of hydrogen sulphide (or other industrial) intoxication. There are two facets to the history in such cases:

**Exposure history:** This attempt to define, in qualitative terms, the likelihood of, and amount of exposure to hydrogen sulphide. This should include questions about work processes, the presence of a rotten egg odour and inquiring as to effects in co-workers. If possible, this should be supplemented by Industrial Hygiene information, which might include the triggering of alarms for hydrogen sulphide and historical data on air measurements. For suspected exposures, the workplace can often provide useful estimates regarding the level of exposure, although such data may require several days to reconstruct.

**Clinical history:** The physician should attempt to establish the presence of as many of the symptoms as possible associated with H<sub>2</sub>S exposure. Determining the presence of respiratory tract irritation (conjunctivitis, rhinitis, tracheitis) is of particular importance since this symptom distinguishes hydrogen sulphide from several other asphyxiants and serious toxicity is unlikely in the absence of this symptom at presentation.

#### Investigations

There are no specific tests in routine clinical use to establish hydrogen sulphide intoxication. Rather, testing is aimed at characterizing the sequels of intoxication, as well as to rule out other causes for the presentation.

## Appendix C: Toxic Gases, continued

### Medical Treatment for Hydrogen Sulphide Exposure, continued

#### Treatment

Treatment is entirely supportive in nature and includes supplemental oxygen, managing eye and skin exposure as a chemical burn and maintenance of circulatory status. Although nitrite therapy has been advocated as an antidote, there is little evidence to support its use and as it is potentially dangerous it is not recommended.

On arrival - check blood gases and assess for lactic acidosis. Take chest film and repeat as necessary keeping in mind the delayed possibility of pulmonary edema. ECG may assist as arrhythmias and bradycardia are not uncommon. Temporary T wave depression may occur and ECG may mimic infarction.

For the unconscious patient, give oxygen using mechanical ventilation with positive end expiratory pressure.

Assess for associated musculo-skeletal and internal traumatic injury.

Maintain circulating fluid volume, but be alert for delayed onset of pulmonary edema.

At times, strong physical restraint may be required. Keep the patient as inactive as possible.

A pulmonary function test should be done near time of discharge and, if abnormal should be repeated at appropriate intervals thereafter.

**If symptoms and/or exposure history are strongly clinically suggestive, because of the possibility of delayed pulmonary edema, adequate monitoring and follow-up for at least 24 hours is essential.**

#### IV. Guidelines for Return to Work (RTW)

Three possible scenarios may be considered by the attending medical personnel:

Possible exposure, without symptoms

Possible exposure, with symptoms (that are compatible with H<sub>2</sub>S)

Known exposure including "knockdown", with symptoms that require medical treatment and/or hospitalization.

In each scenario, a clinical decision about appropriate medical investigations, treatment, follow-up evaluation, and timing of return-to-work (RTW) will have to be made. It is emphasized that with scenarios (1) and (2), it may be preferable to either monitor the employee in the hospital or as an outpatient (with follow-up examination) for 24-48 hours prior to RTW.

## Appendix C: Toxic Gases, continued

### Sulphur Dioxide (SO<sub>2</sub>)

#### Background

Sulphur Dioxide (SO<sub>2</sub>) belongs to the family of sulphur oxide gases (SO<sub>2</sub>). Sulphur is prevalent in raw materials including crude oil and coal, as well as in ore that contains common metals. Sulphur oxide gases form when fuels containing sulphur are burned and when gas is processed or metals are extracted from ore. Like other sulphur oxide gases, SO<sub>2</sub> dissolves in water or water vapour to form acid, and interacts with other gases and particles in the air to form sulphates and other products.

Sulphur dioxide is a colourless gas that is about 2.5 heavier than air. It has a sweet pungent odour, and can be detected by taste and smell at concentrations as low as 300 parts per billion (ppb). Acids that are formed when SO<sub>2</sub> (and nitrogen oxides) react with other substances in the air may be carried great distances before falling to earth as rain, fog, snow or dry particles. Acid rain damages forests and crops, changes the chemical make-up of soils, and increases the acidity of lakes and streams. Continued long-term exposure will affect the natural variety of plants and animals in an ecosystem. As well as contributing to smog, SO<sub>2</sub> emissions cause aesthetic damage and accelerate the decay of building materials and paints.

General guidelines dictate evacuation where SO<sub>2</sub> concentrations reach 5 ppm averaged over a 15 minute period. However, as a precaution, evacuation will be established under the criteria when the SO<sub>2</sub> level reaches 1 ppm for two to three hours, or averages 0.3 ppm over twenty-four hours.

#### Signs and Symptoms

Sulphur dioxide causes a wide variety of health and environmental impacts because of the way it reacts with other substances in the air. Acute and chronic exposure to SO<sub>2</sub> affects the respiratory system. Acute exposure effects, with increasing exposure, include irritation of the eye, nose and throat, choking, coughing, bronchitis and pneumonia. Exposure to low concentrations can aggravate chronic pulmonary diseases, such as asthma and emphysema. Co-exposure to cold or dry air may further exacerbate the respiratory effects of SO<sub>2</sub> on sensitive asthmatics. Particularly sensitive groups include children, the elderly and those with existing heart or lung disease.

#### Sulphur Dioxide Toxicity Table (BC Regulations)

Concentration (ppm)	Effects
0.13	24 hour level (MWLAP Level B Criteria).
0.34	One hour average evacuation level (MWLAP Level B criteria).
2	Eight hour occupational Exposure Limit (WorkSafe BC)
3 – 5	Odour threshold.
5	15 minute Occupational Exposure Limit (WorkSafe BC)
8 – 12	Throat irritation, coughing, constriction in chest, tearing and smarting of the eyes.
10 – 50	5 – 15 minutes exposure produces increased irritation of eyes, nose, and throat, choking, coughing, and in some cases wheezing due to narrowing of the airways (which increases the resistance of the air flow).
150	Short-term endurance lost due to the severe eye irritation and because of the effects on the membranes of the nose, throat, and lungs.
500	Highly dangerous after exposure of 30 – 60 minutes.

*Adapted from the Canada Safety Council Data Sheet "Sulphur Dioxide" No. B-4 Oil and Gas Commission November 2003.*

## Appendix C: Toxic Gases, continued

### Medical treatment for sulphur dioxide exposure

*(Please note: This information was provided by a medical source other than the Provincial Regional Health Authorities. See Sulphur Dioxide (SO<sub>2</sub>) Guidelines - Revised July 2001)*

### Guidelines for in Hospital Assessment/Treatment of Possible Sulphur Dioxide Exposure

This is provided to assist medical staff in assessing a worker who has a possible or actual SO<sub>2</sub> exposure.

Section I provides information on SO<sub>2</sub>

Section II summarizes possible health effects which should be evaluated at the time of presentation

Section III depicts a summary of possible clinical management

Section IV provides a guideline regarding return to work (RTW) considerations.

### I. Sulphur Dioxide

SO<sub>2</sub> is a colourless gas with a pungent odour detectable by the human nose at concentrations of about 0.5 to 0.8 ppm.

SO<sub>2</sub> is highly soluble in water resulting in the formation of sulphurous acid.

Approximately 90% of inhaled SO<sub>2</sub> is absorbed in the upper respiratory tract.

Asthmatics and individuals with underlying bronchial hyperactivity may be more susceptible to low level exposure to SO<sub>2</sub>.

### II. Health Effects of Sulphur Dioxide

SO<sub>2</sub> causes almost immediate coughing with significant exposure.

SO<sub>2</sub> causes irritation of the conjunctive and nasal mucosa at levels between 5 and 10 ppm.

Exposures of SO<sub>2</sub> as low as 8 ppm has been associated with symptoms of cough, phlegm, wheezing and exertional dyspnea.

Acute high-dose exposures leading to severe injury are unusual, parenchyma lung damage occurs above 50 ppm.

## Appendix C: Toxic Gases, continued

### Medical treatment for sulphur dioxide exposure, continued

Acute exposure may include the following symptoms and signs:

#### Respiratory

Inhaled SO<sub>2</sub> is a moderate to strong respiratory irritant. Reddening of the throat and nose may occur. Repeated exposure to 10 ppm has caused nosebleeds. Sensitivity varies among people, short exposure to low concentrations may produce a reversible decrease in lung function, and symptoms may include chest tightness.

Exposure to high concentrations of SO<sub>2</sub> has caused severe airways obstruction, hypoxia and pulmonary edema. The effects of pulmonary edema include coughing and shortness of breath which can be delayed until hours or days after the exposure; these symptoms are aggravated by physical exertion. Survivors of high concentration exposures may suffer chemical bronchopneumonia and bronchiolitis obliterans, which can be fatal after a few days. Delayed chemical pneumonitis and bronchial asthma can also result.

#### Dermal

The gas will react with moisture on the skin and cause irritation (redness, itching).

#### Ocular

Eye irritation may result in smarting of the eyes and tearing. In severe cases (high concentrations in a confined area), SO<sub>2</sub> has caused temporary corneal burns.

#### Potential Sequelae

Survivors of high concentration exposures may suffer chemical bronchopneumonia and bronchiolitis obliterans, which can be fatal after a few days. Delayed chemical pneumonitis and bronchial asthma can also result.

### III. Approach to the worker with suspected Sulphur Dioxide Exposure

Although this document refers only to SO<sub>2</sub>, it is important for the clinician to keep in mind the possibility of co-exposure to numerous other agents.

#### History

The history is the key to the diagnosis of SO<sub>2</sub> (or other industrial) intoxication. There are two facets to the history in such cases:

Exposure history: This attempts to define, in qualitative terms, the likelihood of, and amount of exposure to sulphur dioxide. This should include questions about work processes, the presence of an odour and inquiring as to the effects in co-workers. If possible, this should be supplemented by industrial hygiene information which might include the triggering of alarms for sulphur dioxide and historical data on air measurements. For suspected exposures, the workplace can often provide useful estimates regarding the level of exposure, although such data may require several days to reconstruct.

Clinical history: The physician should attempt to establish the presence of as many of the symptoms as possible associated with SO<sub>2</sub> exposure.

#### Investigations

There are no specific tests in routine clinical use to establish sulphur dioxide intoxication. Rather, testing is aimed at characterizing the sequels of intoxication as well as to rule out other causes for the presentation.

## Appendix C: Toxic Gases, continued

### Medical treatment for sulphur dioxide exposure, continued

#### Treatment

Treatment is entirely supportive in nature and includes supplemental oxygen, managing eye and skin exposure as a chemical burn and maintenance of respiratory status.

On arrival - check blood gases. Take chest film and repeat as necessary keeping in mind the delayed possibility of pulmonary edema.

Oxygen should be delivered by nasal cannula or mask, or if pulmonary injury leads to severe hypoxia by mechanical ventilation.

If bronchospasm occurs, bronchodilators may be of value.

A pulmonary function test should be done near time of discharge and, if abnormal, should be repeated at appropriate intervals thereafter.

Conjunctival irritation should be treated with copious irrigation with saline and the eyes examined with fluorescein for corneal defects.

Assess for associated musculo-skeletal and internal traumatic injury.

Prophylactic antibiotics should be avoided.

If symptoms and/or exposure history are strongly clinically suggestive, because of the possibility of delayed pulmonary edema, adequate monitoring and follow-up for at least 24 hours is essential.

#### IV. Guidelines for Return to Work (RTW)

Three possible scenarios may be considered by the attending medical personnel:

Possible exposure, without symptoms;

Possible exposure, with symptoms (that are compatible with SO<sub>2</sub>) or

Known exposure, including "knockdown", with symptoms that require medical treatment and/or hospitalization.

In each scenario, a clinical decision about appropriate medical investigations, treatment, follow-up evaluation and timing of return-to-work (RTW) will have to be made. It is emphasized that with scenarios (2) and (3), it may be preferable to either monitor the employee in the hospital or as an outpatient (with follow-up examination) for 24 - 48 hours prior to RTW.

## Appendix D: Key Elements of the Incident Command System (ICS)

**Management by Objectives** – Objectives are ranked by priority, should be as specific as possible, must be attainable and if possible given a working time-frame. Objectives are accomplished by first outlining strategies (general plans of action), then determining appropriate tactics (how the strategy will be executed) for the chosen strategy

**Unity and Chain of Command** – Each individual takes direction from and reports to only one designated supervisor; this is called Unity of Command. Higher level personnel have authority over lower level personnel; the lower level personnel are subordinate to and take direction from higher level personnel. Orders and instructions travel down the chain of command from one supervisor to each subordinate. This is called Chain of Command.

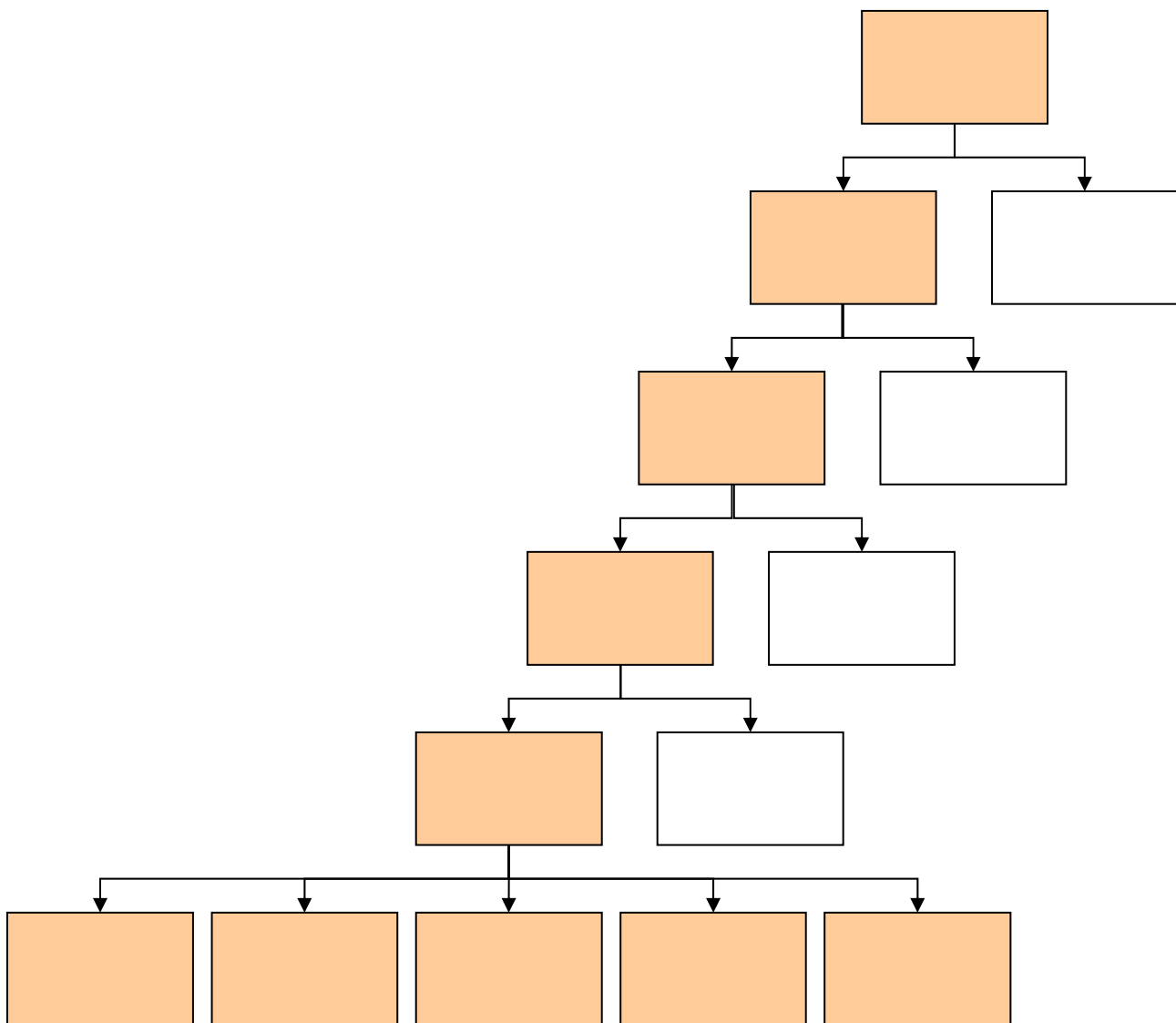

## Appendix D: Key Elements of the Incident Command System (ICS), continued

**Organizational Flexibility** – Only positions that are required at the time should be assigned. In most cases, very few positions will need to be assigned.

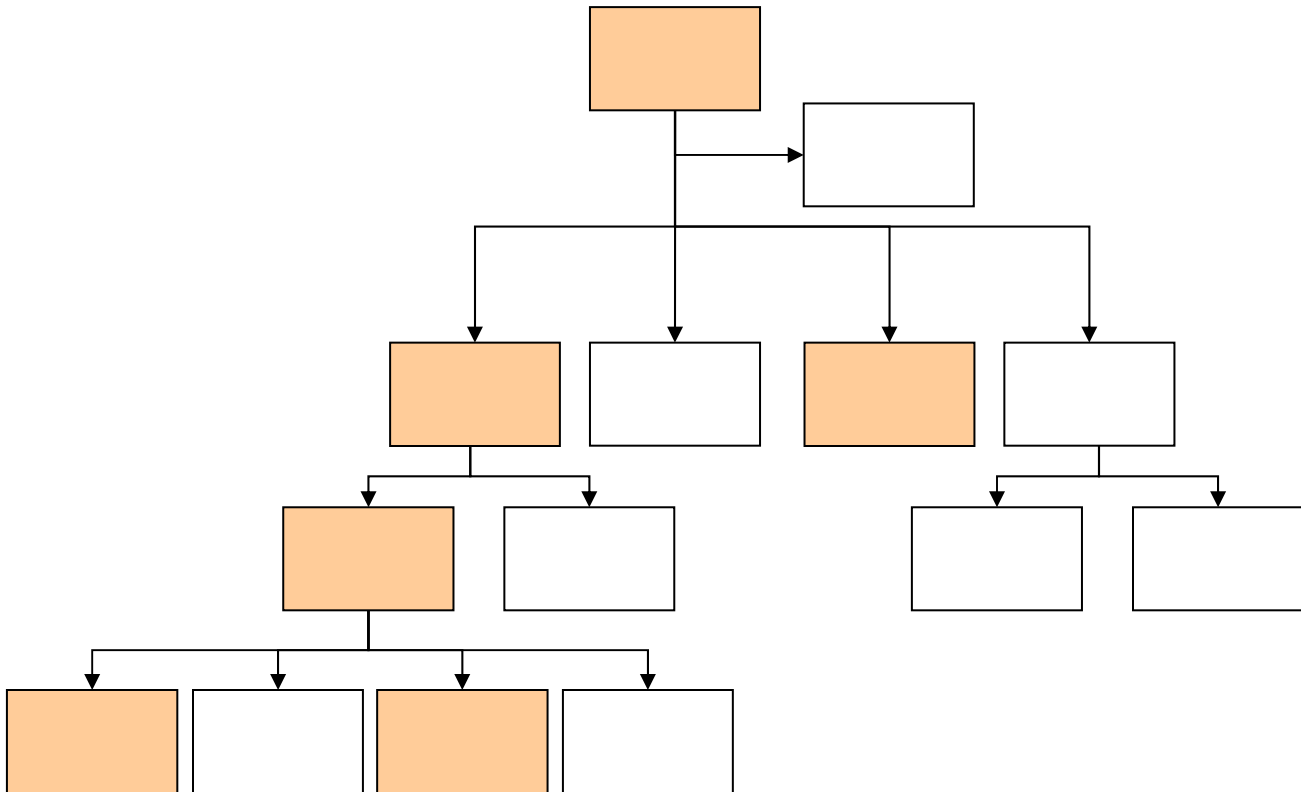

**Span of Control** – ICS requires that any single person's span of control (number of people reporting to them) should be between three and seven, with five being ideal.

**Common Terminology** – When different organizations are required to work together, the use of common terminology is essential.

**Incident Action Plan (IAP)** – Every incident must have a written or oral Incident Action Plan. The following information is part of an Incident Action Plan and must be communicated to the rest of the organization:

- Objectives, strategies and tactics outlined by the Incident Commander.
- Resources assignments – what resources do we have and what are they doing? What resources are on order and what are they going to do?
- A description of the ICS organizational structure – what positions will be filled?
- Supporting materials – incident map, communications plan, evacuation plan, stick diagrams, etc.

**Integrated Communications** – The use of a common communications plan is essential for ensuring effective communication during an incident.

## Appendix D: Key Elements of the Incident Command System (ICS), continued

**Establishment and Transfer of Command** – The highest ranking authority arriving on-scene at an incident will assume the role of the Incident Commander. That person will continue to be the Incident Commander until there is a formal transfer of command. A transfer of command briefing usually consists of:

- Reviewing a description of the incident.
- Reviewing the actions taken thus far to contain and control the incident.
- Reviewing the current ICS organizational structure.
- A summary of the resources available and ordered.

**Resources Management** – A resource must either be in assigned, available, or out-of-service status.

- Assigned – a resource in assigned status is currently doing whatever tasks have been assigned to it.
- Available – a resource in available status is ready to be deployed at a moments notice. Resources in available status often wait for assignments at an incident Staging Area.
- Out-of-Service – a resources in out-of-service status might be sleeping, receiving medical aid, getting repairs, etc. and is not ready for assignment.

### Summary of Responsibilities

These management functions are handled by the General Staff once they have been delegated by the Incident Commander.

**Command** Ensures safety. Assumes overall responsibility for the incident.

The Incident Commander is responsible for the Command of the incident as well as the following management functions until they are assigned to other response personnel:

**Operations** Implements the Incident Action Plan (IAP) focusing on control, containment, and site safety.

**Public Safety** Implements the Incident Action Plan (IAP) focusing on notification and evacuation of the public.

**Planning** Help create and track (document) the success of the Incident Action Plan (IAP).

**Logistics** Secure the resources and put them in place to allow Operations to implement the Incident Action Plan.

**Finance/Admin** Ensures procedures are in place to allow logistics to secure the resources (spending) and track and control the expenditures.

**Communications** Disseminates information and liaises with external agencies.

Communications is handled by the Information Officer once one has been appointed by the Incident Commander. The Information Officer is part of the Command Staff.

## Appendix E: Land Descriptions

### Dominion Land Survey (DLS) System

- Each township (6 mile x 6 mile) is divided into 36 sections (1 mile x 1 mile)
- Each section is divided into 16 legal sub-divisions (L.S.D.)
- Each section is divided into four quarters (N.W., N.E., S.W., and S.E.)

The numbering of sections and L.S.D.s is shown below:

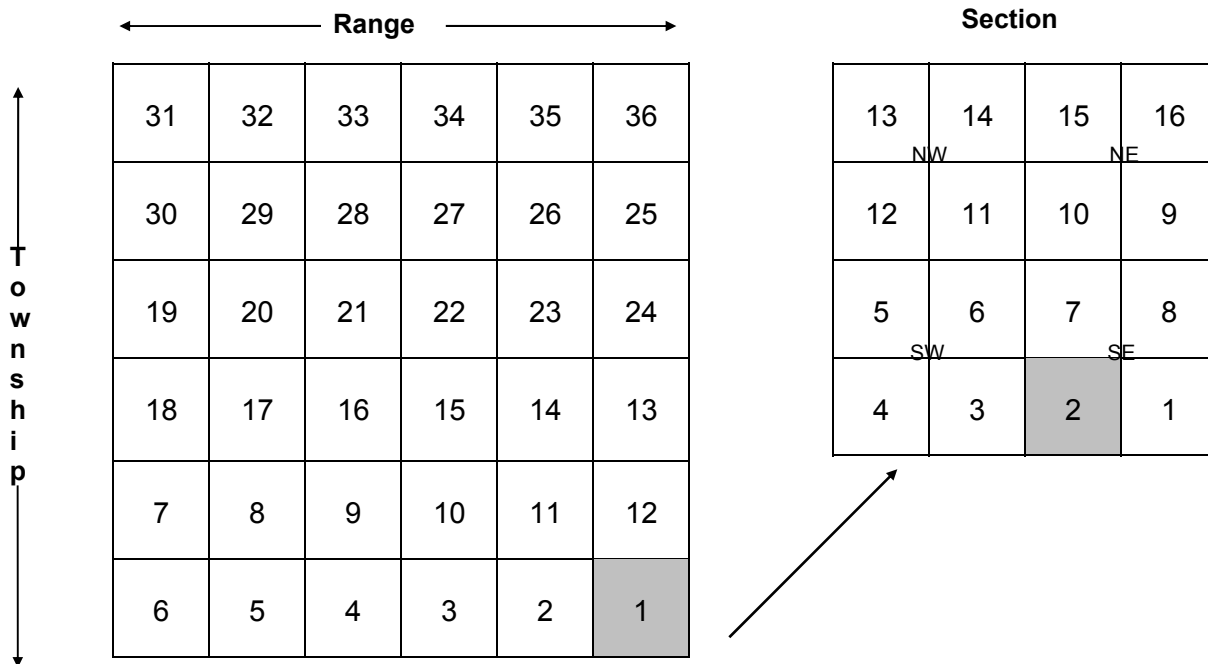

- Townships increase in number from South to North starting at the Canada - USA border
- Ranges increase in number from East to West within a Meridian. A Range is one (1) Township wide (6 miles).
- Meridians run from the North Pole to the South Pole and are spaced every four degrees. The principal Meridian in Canada originates in Central Manitoba and increases West or East from there.
- Legal land description is listed in the following order:

	<u>L.S.D</u>	-	<u>Section</u>	-	<u>Township</u>	-	<u>Range</u>	-	<u>Meridian</u>
Example	02	-	01	-	38	-	09	-	West of the 4 <sup>th</sup>

## Appendix E: Land Descriptions, continued

### National Topographic System (NTS)

Based on the National Topographic System (NTS), the map labelling terms are as follows:

<b>1) Series</b>	A rectangular area that has a width of 8 degrees of longitude and 4 degrees of latitude. There are 9 Series in British Columbia (82, 83, 92, 93, 94, 102, 103, 104, and 114).
<b>2) Area</b>	1/16 of a map Series that has a width of 2 degrees of longitude by 1 degree of latitude (labelled from A to P).
<b>3) Sheet</b>	1/16 of map Area that has a width of 30' in longitude and 15' of latitude (labelled from 1 to 16).
<b>4) Block</b>	1/12 of a map Sheet with a width of 7'30" in longitude and 5' in latitude (labelled from A to L).
<b>5) Unit</b>	1/10 of a map Block, and has a latitudinal extent of 30" and longitudinal extent of 45" (labelled from 1 to 100).
<b>6) Quarter Unit</b>	1/4 of a map Unit (labelled from a to d).

*Note: 1 degree is equivalent to approximately 111 km in British Columbia. Degrees vary in size around the planet. They become smaller the closer they get to the poles (north or south) and very large as they reach the equator.*

#### Example a-29-H / 93-P-9

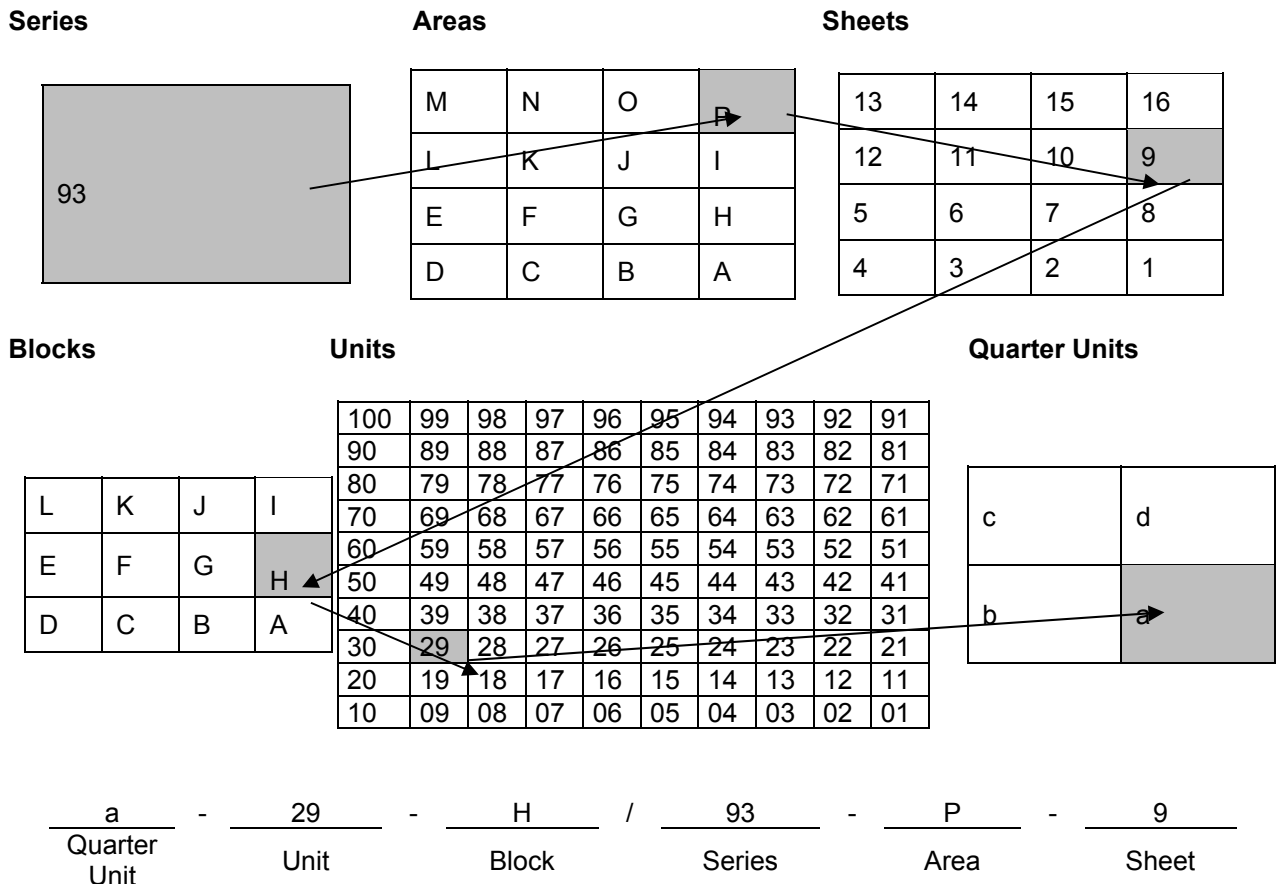

## Appendix F: ERP Reference Material

### Acronyms

Acronym	Meaning	Acronym	Meaning
BCER	BC Energy Regulator	MEP	Municipal Emergency Plan
BLEVE	Boiling Liquid Expanding Vapour Explosion	MER	Ministry of Energy and Resources
CANUTEC	Canadian Transport Emergency Centre	MOP	Maximum Operating Pressure
CAPP	Canadian Association of Petroleum Producers	NGL	Natural Gas Liquids
CEPA	Canadian Environmental Protection Act	NOTAM	Notice to Airmen
CERC	Corporate Emergency Response Centre	OHS	Occupational Health and Safety
CISD	Critical Incident Stress Debriefing	OSCAR	Oil Spill Containment and Recovery
CPE	Communications and Public Engagement	OSCP	On-Site Command Post
CSA	Canadian Standards Association	PAD	Protective Action Distance
DFO	Department of Fisheries and Oceans	PAZ	Protective Action Zone
EAZ	Emergency Awareness Zone	POC	Provincial Operations Centre
ECCC	Environment & Climate Change Canada	PPB	Parts Per Billion
EMCR	Emergency Management Climate Readiness	PPE	Personal Protective Equipment
EMO	Emergency Measures Organization	PPM	Parts Per Million
EOC	Emergency Operations Centre	RCMP	Royal Canadian Mounted Police
EPZ	Emergency Planning Zone	RD	Rural District
ERAC	Emergency Response Assistance Canada	REOC	Regional Emergency Operations Centre
ERP	Emergency Response Plan	RHA	Regional Health Authority
ESD	Emergency Shut Down	RM	Regional Municipality
ESDV	Emergency Shut-Down Valve	SABA	Supplied Air Breathing Apparatus
ETA	Estimated Time of Arrival	SCBA	Self-Contained Breathing Apparatus
FNIHB	First Nations and Inuit Health Branch – Health Canada	SDS	Safety Data Sheet
GEOC	Government Emergency Operations Centre	SO <sub>2</sub>	Sulphur Dioxide
HPZ	Hazard Planning Zone	STARS	Shock Trauma Air Rescue Society
HVAC	Heating Ventilation Air Conditioning	TDG	Transportation of Dangerous Goods
HVP	High Vapour Pressure	WCSS	Western Canadian Spill Service
HVPL	High Vapour Pressure Liquid	WHMIS	Workplace Hazardous Materials Information System
H <sub>2</sub> S	Hydrogen Sulphide		
IAP	Incident Action Plan		
ICS	Incident Command System		
IIZ	Initial Isolation Zone		
INAC	Indigenous and Northern Affairs Canada		
LA	Local Authority		
LBV	Line Block Valve		
LEL	Lower Explosive Limit		
LPG	Liquefied Petroleum Gas		
MD	Municipal District		

## Appendix F: ERP Reference Material, continued

### Glossary of Terms

**Adjacent to**

Within 25 m.

**Air Quality Monitoring**

Measurement of atmospheric concentrations of a hazardous substance, such as H<sub>2</sub>S or SO<sub>2</sub>.

**Auto-ignition temperature**

All NGL products are flammable and will flash at extremely low temperatures. An open flame or spark is not necessary to cause ignition. Any hot surface which exceeds the auto-ignition temperature of a product can cause a fire if the vapours reaching the hot surface are within their flammable range.

**Best practices**

A technique or methodology that, through experience and research, has proven to reliably lead to a desired result. A commitment to using the best practices in any field is a commitment to using all the knowledge and technology at one's disposal to ensure success.

**Body of water**

Streams, lakes, and rivers.

**Boiling Liquid Expanding Vapour Explosion (BLEVE)**

Boiling Liquid Expanding Vapour Explosion, which is associated with natural gas liquids and high vapour pressure liquids.

**Boiling point**

This is the temperature that a liquid changes to a gas. NGL products change to a gas at extremely low temperatures and will absorb heat from the surrounding environment during the phase change. Therefore, caution must be used when working with NGLs because contact with flesh can reduce the temperature of the flesh to the NGL boiling point and cause severe frostbite.

**British Columbia Energy Regulator (BCER)**

The BCER is the lead agency for all regulated oil and gas related activities within British Columbia.

**British Columbia Emergency Management and Climate Readiness (EMCR)**

Aids local governments in analyzing hazards and risks, develop and test emergency plans, train and organize emergency staff and volunteers. EMCR also manages all agencies in the event of an emergency or disaster, which cannot be handled locally.

**Businesses**

Industrial operators, retail outlet operators, suppliers, residents, outfitters, foresters and other entities that normally operate within the Emergency Planning Zone, but do not necessarily reside in the Emergency Planning Zone.

## Appendix F: ERP Reference Material, continued

### Glossary of Terms, continued

#### **Closure order**

When the BCER believes that, because of hazardous conditions in a field or at a well, it is necessary or expedient to close an area and to shut out all persons except those specifically authorized, the commission may make an order in writing setting out and delimiting the closed area. For Alberta see Fire Hazard (FH) Order.

#### **Corporate Emergency Response Plan**

This Emergency Response Plan is to facilitate a co-ordinated response by company executive and management personnel to an emergency situation, which may affect the company or its affiliated companies. The Corporate Emergency Response Plan is an integral part of all site-specific company Emergency Response Plans and procedures.

#### **Critical Incident Stress Debriefing (CISD)**

Critical Incident Stress Debriefing is a specially structured counselling process between the debriefers and those who are directly involved and/or impacted by an incident.

#### **Emergency**

A present or imminent event outside the scope of normal operations that requires prompt coordination of resources to protect the health, safety, and welfare of people and to limit damage to property and the environment.

#### **Emergency Operations Centre (EOC)**

An Emergency Operations Centre is a designated facility in a suitable location (i.e. head office, regional office, etc.) established by the permit holder to support Incident Command and to manage the larger aspects of an emergency. In a high-impact emergency, there may be a number of EOCs established to support the response. They may include the Incident Command Post, regional and corporate EOCs, a municipal EOC (MEOC), and the provincial government EOC (POC).

#### **Emergency Awareness Zone (EAZ)**

A distance outside of the EPZ where public protection measures may be required due to poor dispersion of the hazard. This area is twice the radius of the Emergency Planning Zone (EPZ).

#### **Emergency Planning Zone (EPZ)**

The geographical area that surrounds a well, pipeline or facility containing hazardous product that requires specific emergency response planning by the licensee.

#### **Emergency Response Plan (ERP)**

A comprehensive plan to protect the public that includes criteria for assessing an emergency situation and procedures for mobilizing response personnel and agencies and establishing communication and coordination among the parties.

#### **Emergency Support Team (EST)**

Provides advice and logistical support to the Field Response Team and Incident Commander in particular. The team is comprised of head office personnel and any contract emergency experts.

#### **EOC Director**

The EOC Director activates the Corporate Emergency Operations Centre with staff to provide advice and support to the Incident Commander (Field Response Team). Note: If the emergency happens outside an area that has a site specific Emergency Response Plan, only then will the EOC Director assume or appoint the role of Incident Commander and dispatch a Field Response Team to the incident site

## Appendix F: ERP Reference Material, continued

### Glossary of Terms, continued

#### Evacuation

Organized, phased, and supervised withdrawal of members of the public from dangerous or potentially dangerous areas to safe areas.

**Tactical Evacuation** – A measure to immediately move people to a safe area as part of emergency response and operations. Does not require approval from local authority but the local authority may enact an evacuation order, if required, and local authority must be advised if a tactical evacuation has occurred.

**Planned Evacuation** – An evacuation coordinated by local government authority that can authorize evacuation alerts and orders.

#### Explosive Limits (Lower and Upper)

Each gaseous hydrocarbon substance has a minimum (Lower Explosive Limit or LEL) and a maximum (Upper Explosive Limit or UEL) percentage in air below or above which combustion will not take place. Explosive limit and flammability limit are used interchangeably. The terms "Too Lean" and "Too Rich" are used for levels outside of the explosive range.

#### Facility

Any building, structure, installation, equipment, or appurtenance that is connected to or associated with the recovery, development, production, handling, processing, treatment, or disposal of hydrocarbon-based resources or any associated substance or wastes. This does not include wells or pipelines.

#### Field Response Team (FRT)

Company and contractor personnel directly involved in controlling the incident at the emergency site and from the EOC.

#### Functional Exercise

As described in CAN/CSA Z246.2-18, an activity designed to evaluate capabilities and multiple functions using simulated response. A functional exercise will simulate the deployment of resources and rapid problem solving. Participants will evaluate management of the command and coordination centres and assess the adequacy of emergency response plans and resources.

#### Gathering system

The network of pipelines, pumps, tanks, and other equipment that carries oil and gas to a processing plant or to other separation equipment.

#### Hazard

A situation with potential to harm persons, property, or the environment.

#### Hazard Planning Zone (HPZ)

A geographical area (a) determined by using the hazard planning distance as a radius, and (b) within which persons, property or the environment may be affected by an emergency. Defined in Emergency Management Regulation.

#### Hazardous product

A substance released in quantities that may harm persons, property, or the environment.

## Appendix F: ERP Reference Material, continued

### Glossary of Terms, continued

#### High Vapour Pressure Liquids (HVPLs)

HVPLs have a vapour pressure greater than 240 kPa at 38°C (34.8 PSIG @ 100°F) and include ethane, propane, butane, and pentanes plus, either as a mixture or as a single component.

Note: Comparisons

**Gasoline** - Vapour pressure between 55 and 100 kPa at 38°C (8 - 14.5 PSIG @ 100°F).

**Condensate** - Often a component of a propane/butane mixture, has a vapour pressure of 59 to 72 kPa at 38°C (8.6 - 10.4 PSIG @ 100°F).

#### High Vapour Pressure (HVP) plume dispersion geometry

An uncontrolled release of NGL product on flat terrain will form a vapour plume as it disperses. If the vapour plume formed at the leak site has not been ignited, it will most likely reach its maximum size within the first half hour of the leak occurrence. Two unique features of an NGL plume are:

The downwind edge of the plume tends to spread out significantly forming a broad frontal edge.

Under certain conditions, the plume will travel upwind for a short distance.

#### High Vapour Pressure (HVP) pipeline

A pipeline system conveying hydrocarbons or hydrocarbon mixtures in the liquid or quasi-liquid state with a vapour pressure greater than 110 kilopascals absolute at 38°C. Some examples are liquid ethane, ethylene, propane, butanes, and pentanes plus.

#### High Vapour Pressure (HVP) products

HVP products have a vapour pressure greater than 240 kPa at 38°C (34.8 PSIG at 100°F) and include ethane, propane, butane and pentanes plus, either as a mixture or as a single component. A leak from a vessel or pipe containing HVP products can result in a BLEVE.

#### Hydrogen sulphide (H<sub>2</sub>S)

A naturally occurring gas found in a variety of geological formations and also formed by the natural decomposition of organic matter in the absence of oxygen. H<sub>2</sub>S is colourless, has a molecular weight that is heavier than air, and is extremely toxic. In small concentrations, it has a rotten egg smell and causes eye and throat irritations. Depending on the particular gaseous mixture, gas properties, and ambient conditions, a sour gas release may be:

Heavier than air (dense), so it will tend to drop towards the ground with time,

Lighter than air (buoyant), so it will tend to rise with time, or

About the same weight as air (neutrally buoyant), so it will tend to neither rise nor drop but with time disperse.

#### Hydrogen sulphide (H<sub>2</sub>S) release rate

The rate that sour gas escapes into the atmosphere is often calculated for sour gas wells. It is usually defined in cubic metres per second (m<sup>3</sup>/s). The size of the emergency planning zone is estimated from the H<sub>2</sub>S release rate.

#### Hydrogen sulphide (H<sub>2</sub>S) release volume

The volume of sour gas that escapes into the atmosphere is often calculated for facilities that have a defined retention volume, usually defined in cubic metres. Emergency planning zone sizes are often estimated using the volume of H<sub>2</sub>S that may be released from a facility. More sophisticated models may also incorporate the rate at which the release could occur and the nature of the gas and the atmospheric conditions when determining the emergency planning zone size.

## Appendix F: ERP Reference Material, continued

### Glossary of Terms, continued

**Hyper-susceptible**

A person or persons who may be abnormally reactive to a given exposure to toxins and whose reaction may occur in orders of magnitude greater than that of the susceptible population. Hypersusceptibles include those persons with impaired respiratory function, heart disease, liver disease, neurological disorders, eye disorders, severe anemia, and suppressed immunological function.

**Ignition**

Process of setting a hydrocarbon release on fire.

**Ignition Team**

Consists of at least two personnel trained in plume ignition.

**Incident**

An unexpected occurrence or event that requires action by emergency personnel to prevent or minimize the impacts on people, property, and the environment.

**Incident classification**

A system that examines the risk level to members of the public following an incident and assigns a level of emergency based on the consequence of the incident and the likelihood of the incident escalating.

**Incident Command Post (ICP)**

A designated place where the Incident Commander and staff is located. The ICP should be located outside of the hazard area, but close to the incident. The ICP may be a vehicle, trailer, fixed facility or any location suitable to accommodate the function.

**Incident Commander**

Manages the overall response to emergency incidents. The Incident Commander is responsible for: developing objectives, strategies and tactics that guide the response; assigning personnel to fill necessary positions; ensuring the safety of all personnel; keeping internal and external stakeholders updated; coordinating with other response agencies.

**Incident Command System (ICS)**

A standardized, on-scene, all-hazard incident management system. The Incident Command System (ICS) is flexible in that it can be adapted for large and small incidents.

**Incident Management System**

A system used to coordinate preparedness and incident management.

**Isolating the release**

Ensuring access to the hazard area is controlled.

**Level 1 Emergency**

There is no immediate danger to the public or environment as no H<sub>2</sub>S has been released; the emergency is confined to the lease or company property.

**Level 2 Emergency**

There is potential risk to the public or environment, as the emergency could extend beyond company property. However, control is still possible.

## Appendix F: ERP Reference Material, continued

### Glossary of Terms, continued

**Level 3 Emergency**

An immediate danger to the public or environment exists; control of the situation has been lost.

**Licensee**

The responsible duty holder as specified in legislation.

**Liquid to gas expansion**

NGL products will expand greatly when released to the atmosphere. For example, propane expands 272 times its liquid volume. Other products expand at different rates, but all have a high gas to liquid ratio.

**Liquefied Petroleum Gas (LPG)**

Mixture of heavier, gaseous hydrocarbons (butane and propane), liquefied as a portable source of energy.

**Local Authority**

A local authority is considered to be:

- 1) The council of a city, town, village or municipal district;
- 2) in the case of an improvement district or special area, the Minister of Municipal Affairs;
- 3) for a national park, the park superintendent or the park superintendent's delegate;
- 4) the settlement council of a Métis settlement; or
- 5) the band council of a First Nations Reserve.

**Local State of Emergency**

See State of local emergency.

**Lower Explosive Limit (LEL)**

The lowest concentration of gas or vapour (per cent by volume in air) that explodes if an ignition source is present at ambient temperatures.

**Major (full-blown) exercise**

As described in CAN/CSA Z246.2-18, a multi-agency, multi-jurisdictional activity involving actual deployment of resources in a coordinated response, as if a real emergency had occurred. The full-scale exercise includes the mobilization of units, personnel, and equipment. Participants will assess plans and procedures and evaluate coordinated responses under crisis conditions.

**Maximum Operating Pressure (MOP)**

The maximum licensed operating pressure for a vessel or pipeline or a section of it.

**Ministry of Energy and Resources (MER)**

MER is the lead regulatory agency for the upstream petroleum industry in Saskatchewan.

**Minor Emergency**

There are no consequential impacts to public or environment.

**Mobile air quality monitoring**

Use of sophisticated portable equipment to track substances such as H<sub>2</sub>S or SO<sub>2</sub> at very low parts per billion atmospheric concentrations.

**Municipality**

See local authority.

## Appendix F: ERP Reference Material, continued

### Glossary of Terms, continued

**Municipal Emergency Operations Centre (MEOC)**

The centre from which responsible municipal officials manage and support emergency operations within their jurisdiction, as well as formulate protective actions and provide public information. The centre has adequate workspace, maps, status boards, and communications capability.

**Municipal Emergency Plan (MEP)**

The emergency plan of the local authority.

**Natural Gas Liquids (NGL)**

These are hydrocarbons liquefied under pressure in field facilities or in gas processing plants. Natural gas liquids include ethane, propane, butane and pentanes plus and normally occur as a mixture of these compounds.

Physical Properties of NGL Products:

**Colour** - NGL products are colourless except when they include a condensate component, which gives them a light-yellow appearance. Releases during winter conditions can discolour snow. NGL products may appear as a white cloud when released to the atmosphere. This white cloud is formed by the condensing of moisture in the air.

**Odour** - Most NGL products have a mild petroleum odour. During pipeline transport NGL products are almost odourless.

**Vapour Density** - A measure of the mass per unit volume of the vapour (i.e. kg/m<sup>3</sup>). All NGL products transported by the company have a vapour density greater than air or a relative vapour density greater than 1.0.

**NAV Canada**

Canada's civil air navigation services provider, with operations coast to coast. NAV Canada provides air traffic control, flight information, weather briefings, aeronautical information services, airport advisory services, and electronic aids to navigation.

**Notice to Airmen (NOTAM)**

An order issued by Transport Canada restricting access to airspace in a defined area.

**Notification**

The distribution of project-specific information to participants that may be directly and adversely affected by the proposed energy development.

**Odour complaint**

A report that someone smells an offensive odour (may be sour gas) in the area.

**Oil Spill Containment and Recovery Unit (OSCAR)**

Trailer containing oil spill equipment for containment and recovery.

**On-site command post (OSCP)**

An emergency operations centre established in the immediate vicinity of the incident to provide immediate and direct response to the emergency and initially staffed by licensee personnel.

**Partially controlled flow**

A restricted flow of product at surface that cannot be shut off at the licensee's discretion with equipment on-site.

**Personal consultation**

Consultation through face-to-face visits or telephone conversations with all requisite individuals.

## Appendix F: ERP Reference Material, continued

### Glossary of Terms, continued

**Petroleum industry**

Refers to all petroleum industry operations.

**Plume (gas plume)**

An elongated mobile column of gas or smoke.

**Protective Action Distance (PAD)**

The distance from the incident to the EPZ outer boundary.

**Provincial Operations Centre (POC)**

An operations centre with the capacity to accommodate representatives from each government department.

**Public**

The group of people who may be or are impacted by an emergency (e.g., employees, contractors, neighbours, emergency response organizations, regulatory agencies, the media, appointed or elected officials, visitors, customers, etc., as appropriate).

**Public protection measures**

The use of sheltering, evacuation, ignition, and isolation procedures to mitigate the impact of a hazardous release on members of the public.

**Public Safety Group Supervisor**

Member of the field response team. Individual charged with the responsibility of co-ordinating the evacuation or shelter of people in the emergency hazard Area. The Public Safety Group Supervisor reports to and may be located in the same location as the Incident Commander.

**Publicly used facility**

Places where the presence of people can be anticipated. Examples include places of business, cottages, campgrounds, churches, and other locations created for use by the public. Includes any similar development the BCER may designate as a public facility.

**Publicly used facility**

Places where the presence of people can be anticipated. Examples include places of business, cottages, campground, churches, and other locations created for use by the public.

**Reception centre**

A centre established to register evacuees for emergency shelter, to assess their needs, and, if temporary shelter is not required because evacuees will stay elsewhere, to ascertain where they can be contacted.

**Regional Emergency Operations Centre (REOC)**

An operations centre established in a suitable location to manage the larger aspects of the emergency that is manned jointly by government and industry staff.

**Residence**

A dwelling that is occupied full time or part time.

**Resident**

Individual living in the area at a fixed location.

**Resident data record**

Form used to track the contact made with residents, businesses and transients.

## Appendix F: ERP Reference Material, continued

### Glossary of Terms, continued

**Roadblock Crew**

Personnel responsible for controlling access to the Emergency Hazard Area, reporting to the Public Safety Group Supervisor.

**Rover**

Member of the field response team. Individual responsible for assisting in the evacuation of the Hazard Area, reporting to the Public Safety Group Supervisor. May also be directed to shut-in / shut down equipment that may cause future safety hazards.

**Rover Kit**

A briefcase containing maps, forms, supplies and instructions needed by the Rover to carry out their duties.

**S.A.B.A.**

Supplied Air Breathing Apparatus.

**S.C.B.A.**

Self Contained Breathing Apparatus.

**Serious injury**

A serious injury includes the following:

- an injury that results in death;
- fracture of a major bone;
- amputation other than a portion of a finger or toe;
- loss of sight in an eye;
- internal haemorrhage;
- third degree burns;
- unconsciousness;
- An injury that results in paralysis (permanent loss of function).

**Shelter-in-Place**

Remaining indoors for short-term protection from exposure to toxic gas releases.

**Sour gas**

Natural gas, including solution gas, containing hydrogen sulphide (H<sub>2</sub>S).

**Sour gas release**

An uncontrolled release of natural gas containing hydrogen sulphide (H<sub>2</sub>S).

**Sour multiphase product**

Any liquid that contains H<sub>2</sub>S in the gas phase.

**Sour multiphase pipeline**

A pipeline that transmits a multiphase product that contains more than 10 moles of H<sub>2</sub>S per kilomole of natural gas in the gas phase.

**Sour pipeline**

Pipeline that conveys gas and/or liquid that contains sour gas.

**Sour production facility**

Facility that processes gas and/or liquid that contains sour gas

## Appendix F: ERP Reference Material, continued

### Glossary of Terms, continued

**Sour well**

An oil or gas well expected to encounter during drilling formations bearing sour gas or any oil or gas well capable of producing sour gas.

**Special needs**

Those persons for whom early response actions must be taken because they require evacuation assistance, requested early notification, do not have telephones, require transportation assistance, have a language or comprehension barrier, or have specific medical needs. Special needs also include those who decline to give information during the public consultation process and any residences or businesses where contact cannot be made.

**Special sour well**

A designation that reflects the proposed well's proximity to populated centers and its maximum potential H<sub>2</sub>S release rate during the drilling state. The casing or open-hole flow configuration is used in arriving at this designation.

**Standing well**

A well that has been drilled and cased but not perforated. A company is generally allowed to leave the well as standing for up to one year.

**State of local emergency**

A declaration by a local authority providing the necessary authority, resources, and procedures at the municipal level to allow an emergency to be resolved effectively and efficiently.

**Sulphur dioxide (SO<sub>2</sub>)**

A colourless, water-soluble, suffocating gas formed by burning sulphur in air; also used in the manufacture of sulphuric acid. SO<sub>2</sub> has a pungent smell similar to a burning match. SO<sub>2</sub> is extremely toxic at higher concentrations. The molecular weight of SO<sub>2</sub> is heavier than air; however, typical releases are related to combustion, which makes the gaseous mixture lighter than air (buoyant).

**Surface development**

Dwellings that are occupied full-time or part-time, publicly used development, public facilities, including campgrounds and places of business, and any other surface development where the public may gather on a regular basis. Surface development includes residences immediately adjacent to the EPZ and those from which dwellers are required to egress through the EPZ.

**Susceptible**

The subpopulation of persons who may be considered more sensitive to the effects of H<sub>2</sub>S and SO<sub>2</sub>, including the elderly, pregnant women, and the very young, particularly preschool-aged children.

**Tabletop exercise**

As described in CAN/ CSA Z246.2-18, an informal exercise generally used to review resource allocations and roles and responsibilities of personnel and to familiarize new personnel with emergency operations without the stress and time constraints of a major exercise.

**Technically complete Emergency Response Plan (ERP)**

A plan that meets all applicable requirements.

**Telephoners**

Telephoners place calls to residents as directed by the Public Safety Group Supervisor.

## Appendix F: ERP Reference Material, continued

### Glossary of Terms, continued

**Threatening telephone call**

Any communication that threatens the well-being of company personnel or property. A form is provided in the manual to capture data from or about a person who calls with a threatening message.

**Transient**

An individual that is temporarily in the area (e.g. camper, cross-country skier).

**Trapper**

The holder of a provincial licensed and registered trapline for the purpose of hunting and trapping fur bearing animals.

**Uncontrolled flow**

A release of product that cannot be shut off at the licensee's discretion.

**Urban centre**

A city, town, village, summer village, or hamlet with no fewer than 50 separate buildings, each of which must be an occupied dwelling, or any similar development.

**Unrestricted country development**

Any collection of permanent dwellings situated outside of an urban centre and having more than eight permanent dwellings per quarter section.

**Urban density development**

Any incorporated urban centre, unincorporated rural subdivision, or group of subdivisions with no fewer than 50 separate buildings, each of which must be an occupied dwelling.

**Vapour pressure**

The pressure exerted by the vapour when the rate of evaporation is equal to the rate of condensation of the vapour. All NGL products have vapour pressure greater than atmospheric pressure air and therefore have to be kept under pressure or else they will vaporize.

**Vapour-air plume / vapour cloud**

When released to atmosphere, products form a vapour-air plume that is colourless, heavier than air and has a faint gasoline odour. Depending on the product released and the atmospheric conditions, water vapour may condense to form a cloud.

**Water body**

Natural or manmade; contains or conveys water continuously, intermittently, or seasonally. A natural water body is any location where water flows or is present, whether the flow or the presence of water is continuous, seasonal, intermittent, or occurs only during a flood. This includes, but is not limited to, the bed and shore of a river, stream, lake, creek, lagoon, swamp, marsh, slough, muskeg, or other natural drainage, such as ephemeral draws, wetlands, riparian areas, floodplains, fens, bogs, coulees, and rills. Examples of a manmade water body include, but are not limited to, a canal, drainage ditch, reservoir, dugout or other manmade surface feature.

**Well servicing**

The maintenance procedures performed on a producing or injecting well after the well has been completed and operations have commenced. Well servicing activities are generally conducted to maintain or enhance well productivity or injectivity.

**Workover**

The process of re-entering an existing well to perform remedial action that will restore or improve the productivity or injectivity of the target formation.

# AREA OVERVIEW INFORMATION

<b>EXPANDED SITE SECTION SUMMARY .....</b>	<b>1</b>
<b>FACILITY SUMMARY .....</b>	<b>1</b>
<b>EMERGENCY RESPONSE EQUIPMENT .....</b>	<b>1</b>
SAFETY EQUIPMENT .....	1
ROADBLOCK KITS .....	2
IGNITION KITS.....	2
FIELD SPECIFIC HAZARDOUS PRODUCTS.....	2
<b>TELEPHONE DIRECTORY .....</b>	<b>3</b>
CORPORATE EMERGENCY OPERATIONS CENTRE(S) .....	3
COMPANY PHONE LIST .....	3
SUPPORT SERVICES & CONTRACTORS.....	5
SCHOOL DISTRICTS .....	7
SCHOOLS .....	7
HAZARD ASSESSMENT .....	9
<b>AREA OVERVIEW MAP.....</b>	<b>End</b>

This Page Intentionally Left Blank

## EXPANDED SITE SECTION SUMMARY

This expanded section contains general operations information, Ovintiv’s company phone list, a more in depth support services telephone list and an area overview map. It is intended to support the site specific area information (behind white tabs) which contain all contacts and pertinent information to help carry out an initial response to an emergency.

## FACILITY SUMMARY

The Ovintiv British Columbia Emergency Response Plan contains 2 site sections:

Site Section	Field Coordinator
Dawson North	Shawn Simmonds
Dawson South	Bryan Bonnett

## EMERGENCY RESPONSE EQUIPMENT

### SAFETY EQUIPMENT

All safety equipment is documented and regularly inspected so that equipment is readily available with minimum chance of failure. On-site safety equipment is as follows (**Dawson North / Dawson South**):

Equipment	Quantity
<b>Cutbank – One Island Lake Compressor (b-100-B / 93-P-08), Bistette Field Compressor (d-19-H / 93-P-09) and the Veresen Compressor (a-62-l / 93-P-10)</b>	
30 lb. fire extinguishers	
First aid kits / Eyewash Stations / AEDs	
Well and road map (for Response Team Use)	1
Batteries (“D”)	8
3 Triangle Road Hazard Kit	1
30 minute Self Contained Breathing Apparatus (SCBA) in carrying case	1
30 minute SCBA Breathing Air Cylinders	2
Roadblock equipment	
Flare pistol and flares	
Hand Held Air Horn	1
Rolls of Danger / Caution – Do Not Enter Tape	1 (of each)
Can of Wipe Out Disinfectant	1
Cleaning Rags for Supplied Breathing Air Mask	2
Packs of Ear Plugs	12
Packs of Lens Cleaning Towelettes	12
Packs of Forms	

**EMERGENCY RESPONSE EQUIPMENT, continued**  
**SAFETY EQUIPMENT, continued**

Field Operator's Carry the Following Equipment	
Flare Pistol with shells	Flame-resistant clothing
Ear Protection (Ear muff or expandable type ear plug)	Combustible gas LEL / H <sub>2</sub> S detector
Cellular phone and/or 2 way radio	SCBA with 30 minute air supply

**ROADBLOCK KITS**

Roadblock kits contain the following standard equipment and can be found in all company vehicles.

Equipment	Quantity
Barricade Signs	4
Amber flashing beacons	4
6 Volt Flashlights	2
Spare 6 Volt Batteries	2
Flashlight Directing Batons	4

**IGNITION KITS**

Ignition kits in the Dawson North / South areas can be found at the Cutbank – One Island Lake Compressor (b-100-B / 93-P-08), the Bistette Field Compressor (d-19-H / 93-P-09) and the Veresen Compressor (a-62-I / 93-P-10). and contain the following standard equipment:

Equipment	Quantity
Flare pistol with shells	1
Hard hat with full face protective shields	4
Flame-retardant balaclava hard hat liners, or flame retardant hard hat liners for use with SCBA	4
8' Wind sock, pole and roll of flagging tape	1
Full body rescue harness with 30 metre (100 ft) flame retardant retrieval ropes.	1
Fire blanket	1

**FIELD SPECIFIC HAZARDOUS PRODUCTS**

Ovintiv utilizes MSDS Online to manage SDS sheets for all products that may be found on all Ovintiv locations and operations:

<https://msdsmanagement.msdsonline.com/e6425a45-a6fd-4c66-9c71-a82c96dc59ed/ebinder/?nas=True>

# TELEPHONE DIRECTORY

## CORPORATE EMERGENCY OPERATIONS CENTRE(S)

Location	Contacts
Primary EOC Ovintiv Head Office Bow 29 floor, 500 Centre Street SE, Calgary, AB	Phone: 403-645-2215

## COMPANY PHONE LIST

**REPORT all serious Plant and Field Emergencies immediately to:  
Operations Control Centre (OCC) 780-357-6408  
OVINTIV 24 HOUR EMERGENCY LINE – 403-645-3333**

CONTACT	24 Hour
<b>Emergency Operations Advisor</b> On-call & Safety Emergency	<b>403-645-5911</b>
Ovintiv Public Emergency Line	<b>403-645-3333</b>
Ovintiv Medical Emergency	403-645-5911

CALGARY OFFICE			
NAME	POSITION	PHONE	CELL
Benny, Kelly	Superintendent, Drilling	403-645-8854	403-803-9563
Boychuk, Heather	Manager, Land Operations	403-645-3767	403-966-3767
Geertsen, Kyle	Manager, Field Safety	403-645-3692	403-703-3461
Hearn, Ryan	Director, EHS COA	403-645-4323	403-669-7673
Irvine, Will	Superintendent BC Operations	--	250-219-1979
Johnson, Scott	Manager Completions Engineering	403-645-3975	403-540-2223
Koeksal, Monica	Lead, Land Operations Asset Continuance	403-645-2579	403-861-8266
LaVie, Lance	Superintendent, Shared Services	-	403-324-0457
Lubert, Kevin	Senior Advisor, Completions Operations	403-645-6727	403-813-8957
Lye, Dave	VP Environmental Health & Safety	403-645-6711	403-818-6917
MacDougall, David	Senior Manager Production	403-645-3571	403-816-8205
Maclsaac, Scott	Manager, Drilling Engineering	403-645-4209	403-869-8978
Masse, Mike	Superintendent, Construction	403-645-3673	403-826-8483
Peters, Mark	Field Safety Manager	403-645-3349	403-540-0928
Sarson, Scott	Superintendent, Completions	403-645-5868	403-606-9182
<b>Strangway, Tanner</b>	<b>Senior Emergency Reponse Advisor</b>	<b>403-645-2591</b>	<b>587-585-4901</b>
Syme, Gemma	Manager, Canadian Regulatory & Environment	403-645-3849	403-700-4722
Szopiak, Fil	Senior Manager, Development	403-645-7795	403-710-8992
Thompson, Dave	Sr. Manager, Drilling & Completions	403-645-2741	403-816-8221
Williams, Kim	VP & GM Canadian Operations	403-645-3192	403-861-3252

**Bold** names are key Emergency Contacts

**COMPANY PHONE LIST, continued**

<b>GRANDE PRAIRIE OFFICE</b>			
<b>NAME</b>	<b>POSITION</b>	<b>PHONE</b>	<b>CELL</b>
<b>Burdess, Chris</b>	<b>Operations Control Centre Superintendent</b>	<b>780-513-0585</b>	<b>780-814-1857</b>
Conroy, Rob	Construction Coord., Road & Lease	250-719-6829 x 1128	250-219-7131
Rolick, Adam	Community Relations Advisor	--	250-219-1139
Health, Safety & Environment	Field Advisor - Contact OCC	780-357-6408	--
<b>Penson, Aaron</b>	<b>Operations Control Centre, Lead</b>	--	<b>780-518-0113</b>

**Bold** names are key Emergency Contacts

<b>DAWSON CREEK OFFICE</b>			
<b>NAME</b>	<b>POSITION</b>	<b>PHONE</b>	<b>CELL</b>
<b>Burdess, Chris</b>	<b>Operations Control Centre Superintendent</b>	<b>780-513-0585</b>	<b>780-814-1857</b>
Rolick, Adam	Community Relations Advisor	--	250-219-1139
Health, Safety & Environment	Field Advisor - Contact OCC	780-357-6408	--
<b>Penson, Aaron</b>	<b>Operations Control Centre, Lead</b>	--	<b>780-518-0113</b>

<b>DAWSON NORTH FIELD</b>			
<b>NAME</b>	<b>POSITION</b>	<b>PHONE</b>	<b>CELL</b>
<b>Simmonds, Shawn</b>	<b>Field Coordinator</b>	<b>250-782-2177</b>	<b>250-219-2094</b>
<b>Redmond, Cory</b>	<b>Lead Field Operator</b>	--	<b>250-719-1258</b>
<b>Turry, Brian</b>	<b>Lead Field Operator</b>	--	<b>250-719-3519</b>
<b>Manson, Rob</b>	<b>Lead Plant Operator</b>	--	<b>250-219-1057</b>
<b>Munch, Randy</b>	<b>Plant Coordinator – Dawson North</b>	<b>250-843-3079</b>	<b>250-719-5361</b>

<b>DAWSON SOUTH FIELD</b>			
<b>NAME</b>	<b>POSITION</b>	<b>PHONE</b>	<b>CELL</b>
<b>Bonnett, Bryan</b>	<b>Field Coordinator</b>	--	<b>403-348-3734</b>
<b>Collins, Ryan</b>	<b>Lead Field Operator</b>	--	<b>250-401-8024</b>
<b>Sawers, Byron</b>	<b>Lead Field Operator</b>	--	<b>250-719-4092</b>

<b>TUMBLER RIDGE</b>			
<b>NAME</b>	<b>POSITION</b>	<b>PHONE</b>	<b>CELL</b>
<b>Bonnett, Bryan</b>	<b>Field Coordinator</b>	--	<b>403-348-3734</b>

**Bold** names are key Emergency Contacts

**SUPPORT SERVICES & CONTRACTORS**

<b>Backhoes</b>	<b>Location</b>	<b>Telephone Numbers</b>	
H.F. Nodes Construction	Pouce Coupe	24 Hr.	250-786-5474
Perfection Backhoe Services	Grande Prairie	Admin 24 Hr.	780-539-9725 780-402-1922
Precision Welding Ltd.	Dawson Creek	Admin: 24 Hr.	250-782-5157 888-777-9353
Strait Mechanical Ltd.	Grande Prairie Fort St. John	24 Hr.	587-571-5029 250-785-4200
<b>Communication/Radio Equipment</b>	<b>Location</b>	<b>Telephone Numbers</b>	
Telus National Network Ops Centre	Province Wide	Admin: 24 Hr.	403-530-5000 888-530-7755
BearCom Canada	Grande Prairie	24 Hr.	780-532-2555
Petron Communications	Fort St. John	24 Hr.	250-785-3333
<b>Construction Companies</b>	<b>Location</b>	<b>Telephone Numbers</b>	
Borek Construction Ltd.	Dawson Creek	24 Hr.	250-782-5561
H.F. Nodes Construction	Pouce Coupe	24 Hr.	250-786-5474
Strait Mechanical Ltd.	Grande Prairie Fort St. John	24 Hr.	587-571-5029 250-785-4200
<b>Cranes</b>	<b>Location</b>	<b>Telephone Numbers</b>	
La Prairie Crane	Fort St. John	24 Hr.	877-787-5438
Barnhart (formerly NCSG)	Clairmont Fort St. John	24 Hr.	780-532-8212 250-787-0930
<b>Media</b>	<b>Location</b>	<b>Telephone Numbers</b>	
Big Country 93.1 CJXX	Grande Prairie	Admin: News Room	780-532-0840 780-539-6397
CJDC Television	Dawson Creek	Admin: News Room	250-782-3341 250-782-6397
<b>Supply Stores</b>	<b>Location</b>	<b>Telephone Numbers</b>	
Baron Oilfield Supply Ltd.	Fort St. John Grande Prairied	24 Hr.	250-785-2511 780-532-5661
Distribution Now	Fort St. John	24 Hr.	250-785-5677
<b>Steamers</b>	<b>Location</b>	<b>Telephone Numbers</b>	
Cascade Energy Services	Grande Prairie	24 Hr.	780-513-2655
Peaceland Oilfield Services	Fort St. John	24 Hr.	250-329-8646
<b>Tank Rentals</b>	<b>Location</b>	<b>Telephone Numbers</b>	
Pavlis Trucking Ltd.	Dawson Creek	24 Hr.	250-782-9819
Total Oilfield Rentals	Dawson Creek	24 Hr.	780-532-1994

**SUPPORT SERVICES & CONTRACTORS, CONTINUED**

<b>Trucks - Tank</b>	<b>Location</b>	<b>Telephone Numbers</b>	
Energetic Services Inc.	Fort St. John	24 Hr.	250-785-4761
Formula Powell Tank Service	Fort St. John Grande Prairie	24 Hr.	250-785-4222 780-539-5910
PVT Group	Grande Prairie	24 Hr.	780-830-0045
<b>Trucks – Bed, Trailer &amp; Picker Units</b>	<b>Location</b>	<b>Telephone Numbers</b>	
Mullen Oilfield Services LP	Fort St. John Grande Prairie	24 Hr.	800-663-5931 780-539-5347
Total Oilfield Rentals	Dawson Creek	24 Hr.	780-532-1994
<b>Trucks – Vacuum</b>	<b>Location</b>	<b>Telephone Numbers</b>	
Cascade Energy Services	Grande Prairie	24 Hr.	780-513-2655
Gibson Energy Ltd.	Sexsmith	24 Hr.	866-553-0111
PVT Group	Grande Prairie	24 Hr.	780-830-0045
<b>Welders</b>	<b>Location</b>	<b>Telephone Numbers</b>	
Highmark Oilfield Services Ltd.	Fort St. John	24 Hr.	250-793-7155
Precision Welding Ltd.	Dawson Creek	Admin: 24 Hr.	250-782-5157 888-777-9353

**SCHOOL DISTRICTS**

<b>Name</b>	<b>Location</b>	<b>Office</b>
<b>Peace River South #59*</b>	Dawson Creek	<b>250-782-8571</b>
Christy Fennell - Superintendent		
Jeff Lekstrom – Transportation Manager		250-782-2106 (o) 250-219-1503 (c)
<b>Name</b>	<b>Location</b>	<b>Office</b>
<b>Peace Wapiti School Division #76**</b>	Grande Prairie	<b>250-532-8133</b>
Shawn O'Shea - Superintendent		
Ted Gobin – Transportation Manager		780-532-7734 (o) 780-402-1576 (c)

**SCHOOLS**

<b>Name</b>	<b>Location</b>	<b>Office</b>
Alaska Highway Christian School	Dawson Creek	250-789-3030
Bonanza School**	Bonanza	780-353-3788
Canalta Elementary (K - Gr. 7)*	Dawson Creek	250-782-8403
Crescent Park Elementary (K - Gr. 7)*	Dawson Creek	250-782-8412
Dawson Creek Secondary (Central Campus) (Gr. 8-9)*	Dawson Creek	250-784-7676
Dawson Creek Secondary (S. Peace Campus) (Gr.10-12)*	Dawson Creek	250-782-5585
<b>Devereaux Elementary School (K - Gr. 7)*</b>	Dawson Creek	250-843-7300
Ecole Frank Ross Elementary (K - Gr. 7)*	Dawson Creek	250-782-5206
Mountain Christian School (K - Gr.12)	Dawson Creek	250-782-9528
Notre Dame School (K - Gr.12)	Dawson Creek	250-782-4923
<b>Parkland Elementary (K - Gr. 7)*</b>	Peace River Regional District	250-843-7777
Pouce Coupe Elementary (K - Gr. 7)*	Pouce Coupe	250-786-5314
South Peace Child Development Centre (Pre K)	Dawson Creek	250-782-1161
South Peace Elementary (K - Gr. 9)*	Dawson Creek	778-299-2037
Trembley Elementary School (K - Gr. 7)*	Dawson Creek	250-782-8147

**School is within the Dawson North EPZ**

This Page is Intentionally Left Blank

Pages  
Redacted:  
Sensitive  
Information